

rotork®

Gears

232 Quarter-turn Cast Aluminium Housing Gearboxes

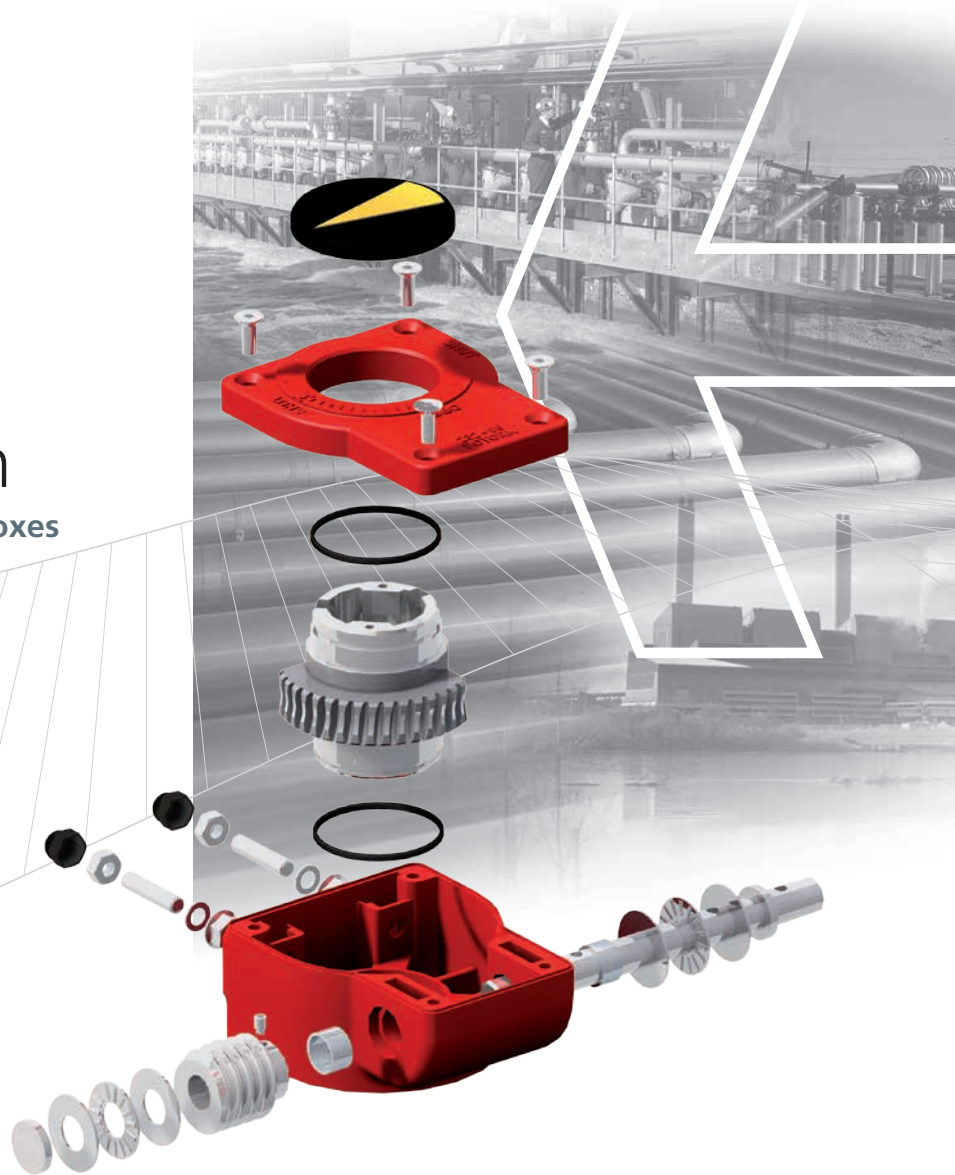

232 Quarter-turn Gear Series

The new 232 cast aluminium housing range of 1/4 turn worm gearboxes was designed with cost in mind but above all to enhance its quality, reliability and environmental specifications. This was achieved by looking at reducing costs in various areas. A reduction in component weights coupled with the standardization of the gearbox enables a reduction in stock and consequently cost effective transport and logistics.

The product is flexible and configurable either in our factory or at the customer's site, to improve and maintain a consistent delivery.

Application

The 232 series 1/4 turn worm gearboxes are intended for the operation of ball, butterfly, plug and any other 1/4 turn valves. They are well suited for applications in power waterworks and gas pipelines, HVAC, fire protection and most general industrial applications.

Features

- Removable stem drive inserts
- Various inserts to suit all valve stems
- Various PCDs on gearcase according to ISO 5211
- 2 keyways to cater for 45° & 90° positions
- Easy to customise
- Delivery in days not weeks
- Lightweight design
- High performance gears to increase torque not size
- Improved ingress protection
- Specially designed sealing
- IP 65
- Protected steel shafts and fasteners
- Temperatures -20 to +120 °C (-4 to +250 °F)
- Built in mechanical stops
- Prepared for padlock kit, namur connections and memory stop mounting
- Various handwheel types and sizes
- Selflocking

Options

- Limit switches inside or outside gearbox, conforming to VDI/VDE 3845 Standard
- Stainless Steel shafts
- Various position indicators
- Various handwheels
- Memory stop
- Padlocking device
- Various inserts
- Flexible Extensions

Redefining Flow Control

Dystrybutor:

ARA

PNEUMATIK

53-012 Wrocław tel. 71 364 72 85
ul. Wyścigowa 38 fax 71 364 72 83

www.arapneumatik.pl



Material Specification

No.	Description	Material	Notes
1	Set Screw	Steel	ELVZ 8,8 / DIN 916
2	Needle Bearing	AXK-AS/LS	-
3	Worm Screw	Steel	ELVZ 12,9 / DIN 915
4	Worm	Carbon Steel	C45 / AISI 1045
5	Plain Bearing	Permaglide	E40
6	Oil Seal	Nitrile	-
7	Shaft	Protected Steel	-
8	Renolit CLX2	Calcium Soap	Multipurpose CLX
9	Body	Aluminium	Grade LM 9
10	Coverplate	Aluminium	Grade LM 9
11	Quadrant*	Ductile Iron	GGG40 / ASTM D60-40-18
12	Position Indicator	Scanblend FS7	-
13	Nutcap	Polyethylene	-
14	Inserts	Sintered Steel	See selection table

*232-08 quadrant is GGG70

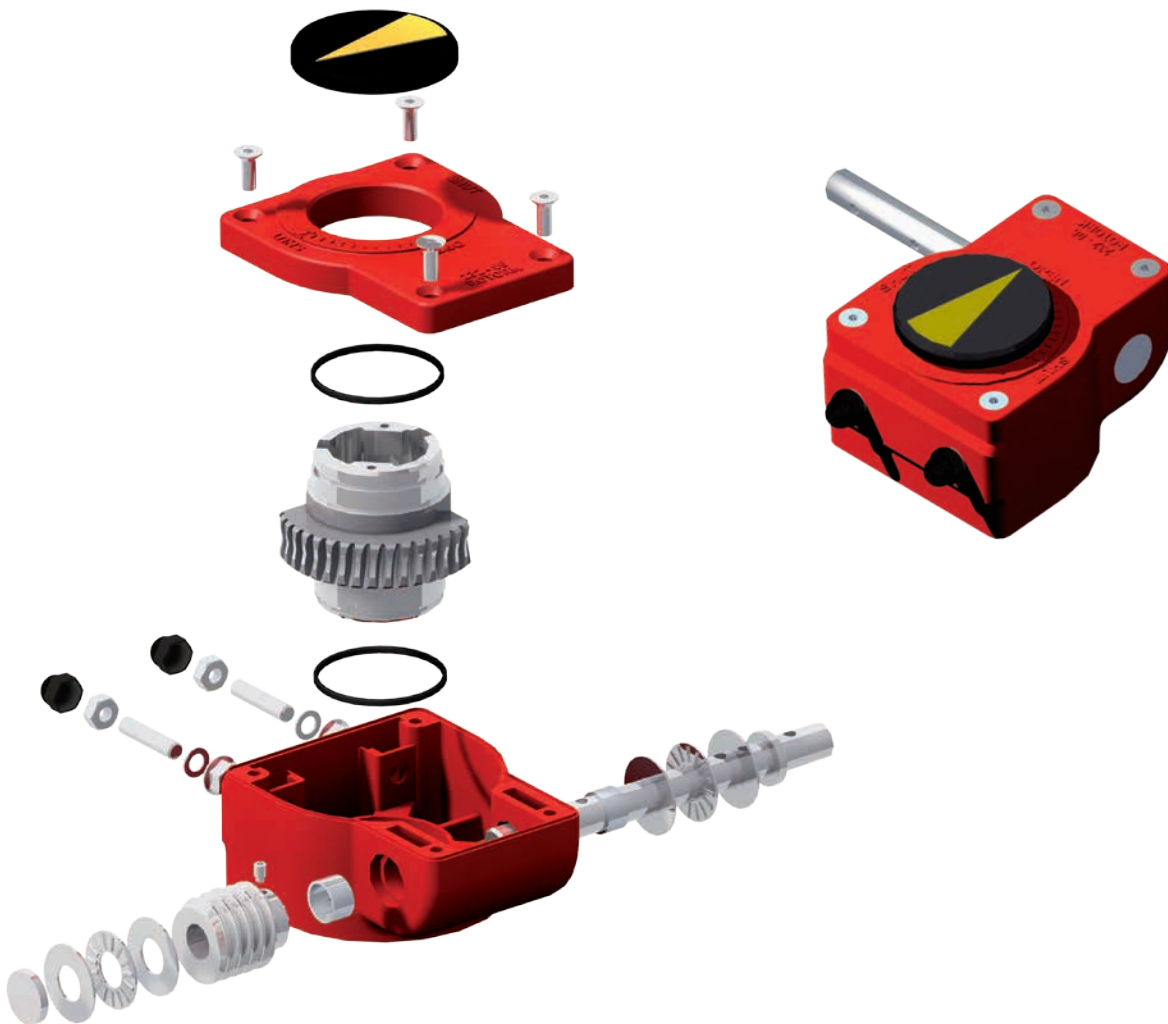

232 Quarter-turn Cast Aluminium Housing Gearboxes

Gearbox 232 Series

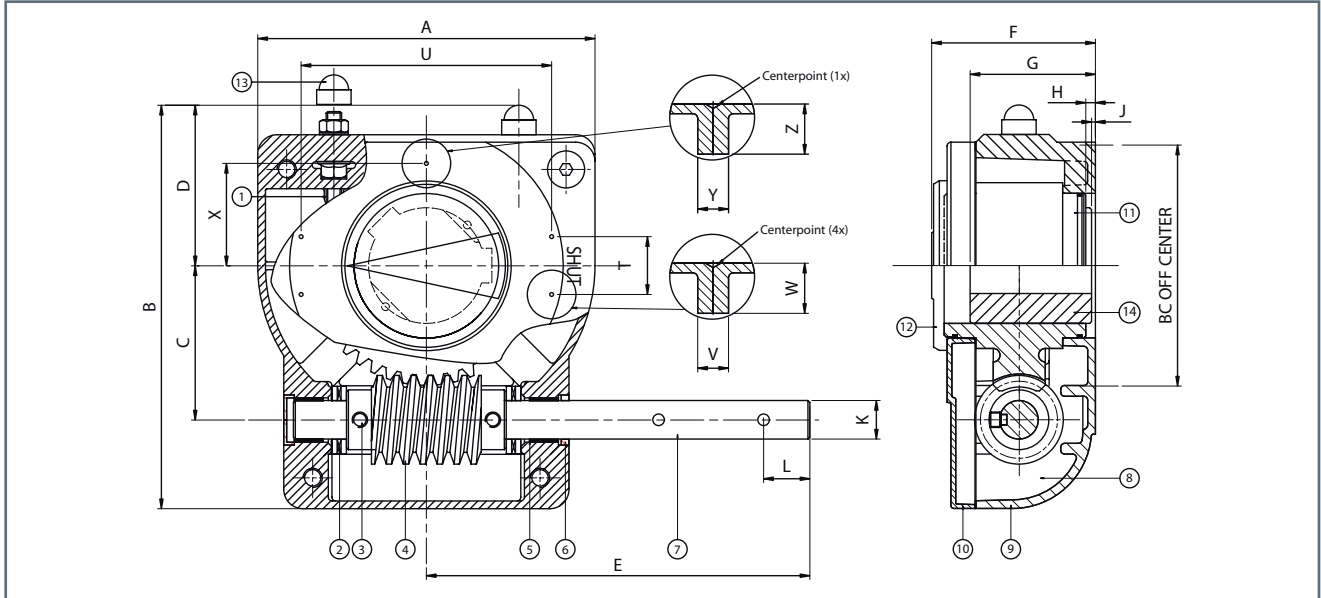

Inserts Valve Stem Variations

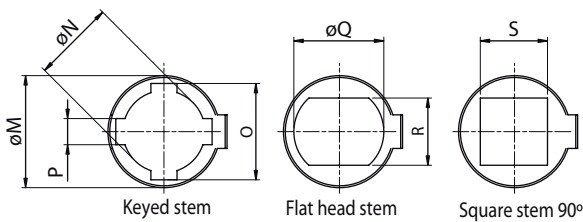

Type	Ratio	Torque Nm (lb. inch)		M.A. ± 15%	Weight Kg (lb)
		Output	Input		
232-05	40 : 1	125 (1100)	12,5 (110)	10,0	0,8 (1,8)
232-06	40 : 1	250 (2200)	25 (220)	10,0	0,9 (2,0)
232-08	37 : 1	500 (4400)	41,7 (362)	12,0	1,55 (3,43)
232-11	45 : 1	900 (7920)	75 (660)	12,0	2,9 (6,3)
232-13	40 : 1	1000 (8800)	83 (730,4)	12,0	5,4 (11,9)
232-14	40 : 1	1500 (13200)	125 (1103)	12,0	5,4 (11,9)
232-15	40 : 1	1500 (13200)	125 (1103)	12,0	5,4 (11,9)

The static safety factor is 1.5.

The published M.A. is achieved after a few cycles.

Type	A	B	C	D	E	F	G	H	J	øK	L	Valve Connection BC acc. ISO 5211
232-05	80 (3,15)	114 (4,49)	42,5 (1,67)	48 (1,89)	105 (4,13)	53 (2,11)	39,5 (1,56)	2,5 (0,10)	2,5 (0,10)	12 (0,47)	14 (0,55)	F04 / F05 / F07
232-06	80 (3,15)	114 (4,49)	42,5 (1,67)	48 (1,89)	155 (6,10)	59 (2,32)	46 (1,81)	2,5 (0,10)	1 (0,4)	12 (0,47)	14 (0,55)	F05-F07
232-08	100 (3,94)	131 (5,16)	50 (1,98)	56 (2,21)	170 (6,69)	67 (2,64)	58,5 (2,30)	4 (0,16)	2,5 (0,10)	12 (0,47)	14 (0,55)	F07-F10
232-11	146 (5,75)	174 (6,84)	60 (2,36)	79 (3,13)	200 (7,87)	79 (3,11)	71 (2,80)	7 (0,28)	2,5 (0,10)	15 (0,59)	14 (0,55)	F10-F12
232-13	175 (6,89)	209 (8,24)	80 (3,15)	83 (3,28)	280 (11,02)	85 (3,33)	76,5 (3,01)	5 (0,20)	2 (0,08)	20 (0,74)	24 (0,94)	F10-F12 / F14
232-14	175 (6,89)	209 (8,24)	80 (3,15)	83 (3,28)	280 (11,02)	85 (3,33)	76,5 (3,01)	5 (0,20)	2 (0,08)	20 (0,74)	24 (0,94)	F10-F12 / F14
232-15	175 (6,89)	209 (8,24)	80 (3,15)	83 (3,28)	280 (11,02)	85 (3,33)	76,5 (3,01)	5 (0,20)	2 (0,08)	20 (0,74)	24 (0,94)	per application

Type	Maximum Dimensions													
	øM	øN	O	P	øQ	R	S	T	U	V	W	X	Y	Z
232-05	25 (0,98)	15 (0,59)	19,6 (0,77)	5 (0,2)	18,1 (0,71)	14 (0,55)	14 (0,55)	25 (0,98)	50 (1,97)	8 (0,31)	13 (0,51)	23,5 (0,93)	8 (0,31)	8 (0,31)
232-06	32,15 (1,27)	20 (0,79)	25,2 (0,99)	6 (0,24)	22,2 (0,87)	17 (0,67)	17 (0,67)	25 (0,98)	50 (1,97)	8 (0,31)	13 (0,51)	26,5 (1,04)	8 (0,31)	10 (0,39)
232-08	45,3 (1,78)	30 (1,18)	36,6 (1,44)	8 (0,31)	36,2 (1,43)	27 (1,06)	27 (1,06)	30 (1,18)	80 (3,15)	10 (0,39)	14 (0,55)	35 (1,38)	10 (0,39)	10 (0,39)
232-11	60 (2,36)	44 (1,73)	52,6 (2,07)	14 (0,55)	48,2 (1,90)	36 (1,42)	36 (1,42)	30 (1,18)	130 (5,12)	10 (0,39)	14 (0,55)	53 (2,09)	10 (0,39)	14 (0,55)
232-13	60 (2,36)	44 (1,73)	52,6 (2,07)	14 (0,55)	48,2 (1,90)	36 (1,42)	36 (1,42)	30 (1,18)	130 (5,12)	10 (0,39)	14 (0,55)	53 (2,09)	14 (0,55)	14 (0,55)
232-14	60 (2,36)	44 (1,73)	52,6 (2,07)	14 (0,55)	48,2 (1,90)	36 (1,42)	36 (1,42)	30 (1,18)	130 (5,12)	10 (0,39)	14 (0,55)	53 (2,09)	14 (0,55)	14 (0,55)
232-15	-	55 (2,17)	63,8 (2,5)	16 (0,63)	52 (2,05)	46 (1,81)	46 (1,81)	30 (1,18)	130 (5,12)	10 (0,39)	14 (0,55)	53 (2,09)	14 (0,55)	14 (0,55)

All dimensions in millimetres. The 232-15 has a blank bore and base plate for machining to suit various top works.

Inserts are not retained in the gearbox, please specify if required.

Handwheel Selection Chart

Input Torque

Type	M.A. ± 15%
232-05	10
232-06	10
232-08	12
232-11	12
232-13	12
232-14	12
232-15	12

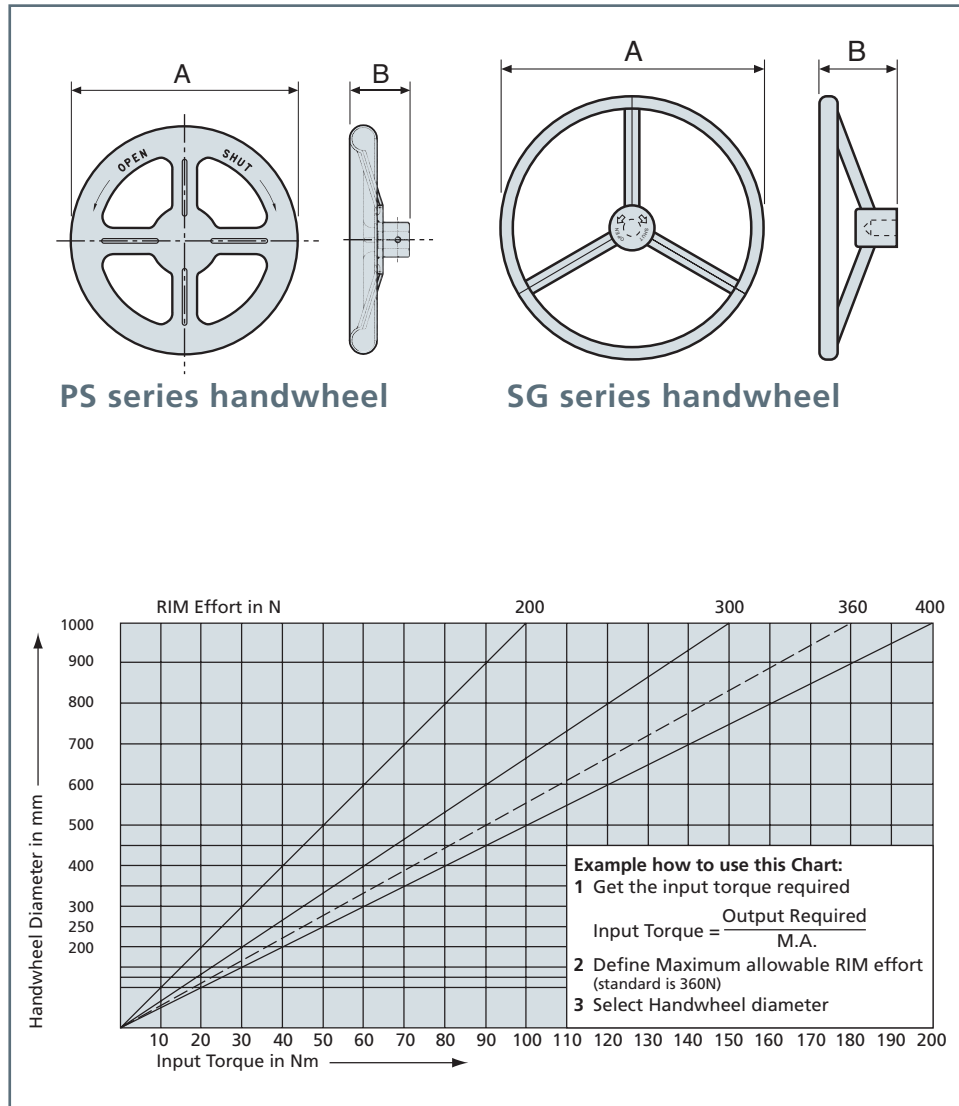

Rotork Gears BV
Nijverheidstraat 25
7581 PV Losser
P.O. Box 98
7580 AB Losser
The Netherlands

tel +31 (0)53-5388677
fax +31 (0)53-5383939
email info@rotorkgears.nl

Rotork Gears UK
9 Brown Lane West
Holbeck
Leeds
West Yorkshire LS12 6BH
England

tel +44 (0)113 2567922
email sales@rotorkgears.com

Rotork Gears Americas
1811 Brittmoore
Houston
Texas 77043
USA

tel +1 713 983 7381
fax +1 713 856 8022
email gears@rotorkgears.com

Rotork Gears S.R.L.
via Olona, 65/67
20015 Parabiago (MI)
Italy

tel +39 0331 552128
fax +39 0331 553147
email info@rotorkgears.it

Rotork Gears Shanghai
No. 260 Lian Cao Road
Xin Mei Urban Industrial Park
Min Hang District
Shang Hai 201108
China

tel 0086-21-33236200
fax 0086-21-64348388
email info@rotorkgears.com.cn

A full listing of our worldwide sales and service network is available on our website at

www.rotork.com

Rotork Gears India
165/166, Bommasandra,
Jigani Link Road,
Kiadb Industrial Area,
Anekal Thaluk, Jigani Hobli,
Bangalore 562106

tel +91 80 3098 1600
fax +91 80 3098 1610
email sales@rotork.co.in

Rotork Valvekits
Brookside Way
Nunn Park
Huthwaite
Nottinghamshire NG17 2NL
England

tel +44 (0)1623 440211
fax +44 (0)1623 440214
email sales@rotorkvalvekits.com

Rotork Valvekits Americas
Renfro Associates Inc
501 South 12th Street
Broken Arrow, OK
74012
USA

tel +1 (918) 259-8100
fax +1 (918) 259-9167
email info@renfroassociates.com