

LF 3000® Push-In Fittings / Self-Sealing and Oscillating Fittings



2 functions available for quick machine intervention and to facilitate the operation of the installations.

Ø metric:
4 to 12 mm

Technical Characteristics

- **Compatible Fluids:** Compressed air
Other fluids: please consult us
- **Working Pressure:** Vacuum to 20 bar
(10 bar: self-sealing fitting)
- **Working Temperature:** -20°C to +80°C

Reliable performance is dependent upon the type of fluid conveyed, component materials and tubing being used.

Use is guaranteed with a vacuum of 755 mm Hg (99% vacuum).

Advantages

- **Self-Sealing Fittings**
 - Prevents fluid flow when there is no tube connected
 - When connected, the compressed air flow is restored
- **Oscillating Fittings**
 - Fitting swivels when cylinder is in movement : no bending of the tube
 - High durability of the fitting/tube assembly

Component Materials

Swivel Fitting

- Body:
- Self-sealing fitting: nickel-plated brass
 - Oscillating fitting: technical polymer

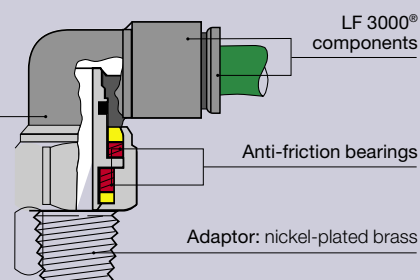

Silicone-free

Regulations

- ISO 14743
- PED
- RoHS
- REACH

Installation Configurations

Self-Sealing Fitting

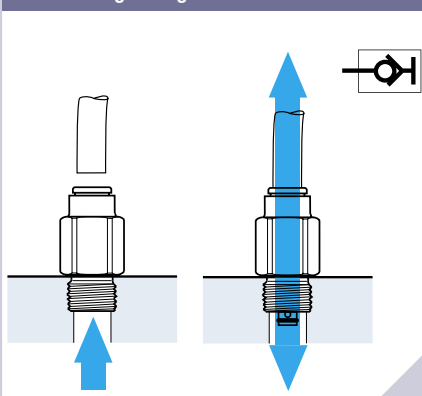

Oscillating Fitting

Tube O.D. (mm)	Torque (daN.m)	Max. Rotation Speed (turn/min.)
4	<math> < 2.5 \cdot 10^{-3}</math>	190
6	<math> < 4 \cdot 10^{-3}</math>	160
8	<math> < 7 \cdot 10^{-3}</math>	120
10	<math> < 11 \cdot 10^{-3}</math>	90
12	<math> < 16 \cdot 10^{-3}</math>	80

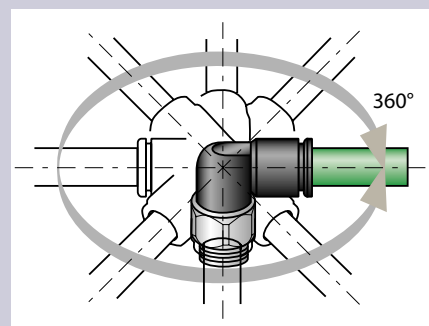

3189 Oscillating Elbow, Male BSPP and Metric Thread

Technical polymer, Nickel-plated brass, NBR

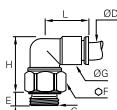

ØD	C		E	F	G	H	L	Kg
4	M5x0.8	3189 04 19	3	12	11	24.5	17.5	0.012
	G1/8	3189 04 10	5	13	11	23	17.5	0.014
6	M5x0.8	3189 06 19	3	12	14	27.5	20.5	0.017
	G1/8	3189 06 10	5	14	14	27	20.5	0.019
	G1/4	3189 06 13	5.5	16	14	25.5	20.5	0.023
8	G1/8	3189 08 10	5	17	16	33.5	23.5	0.034
	G1/4	3189 08 13	5.5	17	16	31	23.5	0.032
10	G3/8	3189 08 17	5.5	20	16	29.5	23.5	0.039
	G1/4	3189 10 13	5.5	19	19.5	39	29	0.053
12	G3/8	3189 10 17	5.5	20	19.5	37	29	0.051
	G1/4	3189 12 13	5.5	21	22	46.5	33.5	0.073
	G3/8	3189 12 17	5.5	21	22	45.5	33.5	0.071

DYSTRYBUTOR PARKER PREMIUM

ARA[®]
PNEUMATIK

| arapneumatik.pl

PARKER STORE WROCLAW
pneumatyka@arapneumatik.pl
TEL. 71 364 72 80

PARKER STORE KATOWICE
katowice@arapneumatik.pl
TEL. 32 779 76 40

