

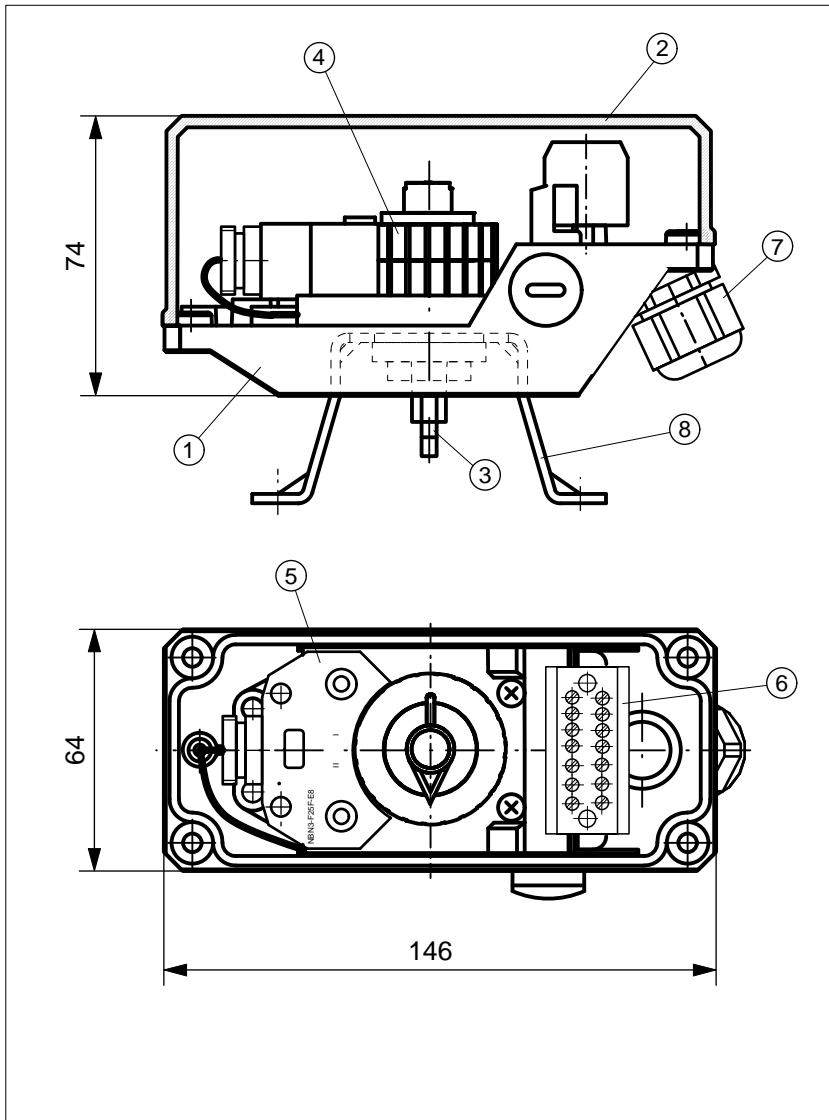

TPFF25EMVAZ

TCR-Module with double sensor Pepperl+Fuchs NBN3-F25F-E8
in TCR-Housing 146 x 64 x 74 mm



TECHNICAL DATA

Manufacturer: Pepperl+Fuchs
 Type: NBN3-F25F-E8
 inductive, PNP,
 Normally open contact

Operating distance: 3 mm
 Operating voltage: 10 ... 30 V DC
 Switch. frequency: 0 ... 500 Hz
 Operating current: 0 ... 200 mA
 Output: short-circuit protection
 reverse-polarity protection

Temperature: -25 ... +70°C
 Signal: LED, yellow
 Housing base: Vestamid, black
 Housing cover: Macrolon, clear
 Sealing: EPDM
 Ingress protection: IP67 (Sensor)
 IP65 (Housing)

Switching precision: <0.5°
 System connection: Cable gland M20x1,5

WIRING DIAGRAM

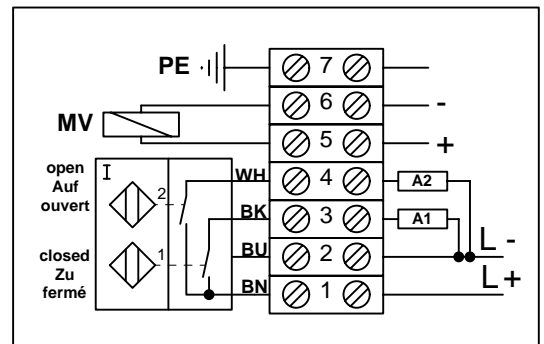

OBJECT LIST

Pos.	Pcs.	Description	Material
1	1	Housing base	Vestamid
2	1	Housing cover	Macrolon
3	1	TCR-Axis	POM
4	1	Switch cam system	POM, A2
5	1	P+F NBN3-F25F-E8	
6	1	Terminal block, 7-pole	-
7	1	Cable gland M20x1,5	-
8	1	Bracket size 1-4	A2

Więcej informacji - skontaktuj się z nami:

ARA[®]
PNEUMATIK



ul. Wyścigowa 38 53-012 Wrocław
tel. +48 71 364 72 85, 691 112 333
armatura@arapneumatik.pl

arapneumatik.pl