



AIR TORQUE®



4th Generation Line
Upgrade Series

PNEUMATIC ACTUATORS



ATEX 94/9/EC



SIL3 IEC 61508



GOST-R

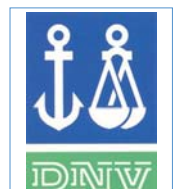

TYPE APPROVAL



The 4th Generation Line pneumatic actuators, Upgrade Series, are the result of the Air Torque mission to offer always innovative products by combining the long field experience as market leader, the innovational spirit, the well-known reliability in actuator designing and the high quality manufacturing level.

The Air Torque experience has produced the following main key features included in the 4th Generation Line, *Upgrade Series*:

Reliable and flexible solutions

By combining high quality products, field and design experience, Air Torque is able to satisfy all the customers and market expectations by offering reliable, flexible and customized solutions together with a qualified service.

Innovative Patented Design

The new technical features developed and incorporated in the 4th Generation Line pneumatic actuators, *Upgrade Series*, permit to have the best product versatility for an easier and easier valve automation. The Upgrade Series are covered by five International patents.

The most complete range and options

The *Upgrade Series* pneumatic actuators are available in:

- Eighteen models
- Spring return and double acting versions
- Torque up to 10.000 Nm
- Six different protection levels
- Low and high temperature constructions
- Large availability of many ISO flanges and drive shaft connections for direct valve automation
- 120°-135°-180° rotation both in double acting and spring return
- 180° spring return Fail-Mid
- 3 Position actuators, 90° and 180° rotation, both double acting and spring return versions
- Fast acting actuators
- Hydraulic damper actuators

High quality level production

The 4th Generation Line pneumatic actuators, *Upgrade Series*, have been designed and tested to obtain the highest cycling life and the most reliable performance with very reduced maintenance and service.

International Standard

The 4th Generation Line pneumatic actuators, *Upgrade Series*, have been designed, manufactured and tested in full compliance with all the applicable International standards.

Technology and material

The 4th Generation Line pneumatic actuators, *Upgrade Series*, are manufactured with the highest material quality, the most accurate material selections and the latest production technologies.



TECHNICAL FEATURES

1. Alodur hard anodized body

Extruded aluminum body with Alodur special hard anodization applied internally and externally for a complete corrosion protection, a lower friction coefficient and an increased surface hardness for the longest wearing resistance.

Many additional protective coatings are available on the external surface for different environmental working conditions.

2. Pistons design

Dual piston rack and pinion design for compact construction, symmetric mounting position, high-cycle life and fast operation, reverse rotation can be accomplished in the field by simply inverting the pistons. Both pistons are anodized for a better corrosion and wearing resistance.

3. Two independent external travel stop adjustments

As a standard, travel stops allowing adjustment for -5° up to $+15^\circ$ on the close position, and for $+5^\circ$ up to -15° on the open position. This allows accurate valve alignment, stroke limitation and provides on actuator a large travel adjustment.

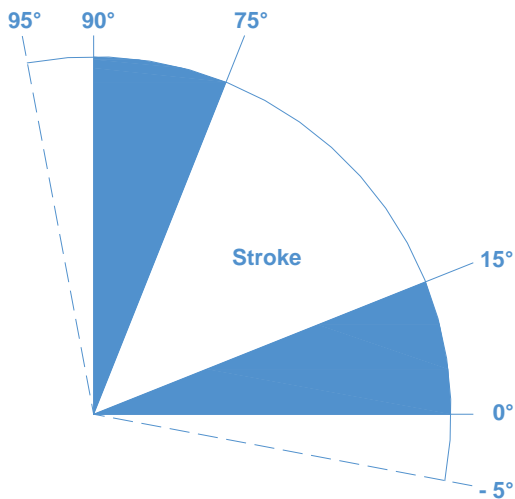

4. Universal and anti-blowout drive shaft

It permits an easy conversion from parallel to diagonal square and vice versa. It is also available in double square; both solutions permit a lower and more flexible inventory.

5. Drive shaft top adaptor

The aluminum top adaptor for ancillary driving/attachment gives a more precise and stable coupling with ancillary stem suitable for higher temperature application. It is suitable and available both for single (diagonal and parallel) and double square drive shafts.

6. One compact and modern design

With identical body and end caps for double acting and spring return model to reduce inventory, allows field conversion, by adding or removing modular spring cartridge.

7. Position indication

The combination of the new top adaptor and the new position indicators allows to achieve easily the correct actuator/valve position indication by just rotating of 90° the top adaptor and the indicator. This operation can be easily done also on the field by avoiding the actuator disassembling.

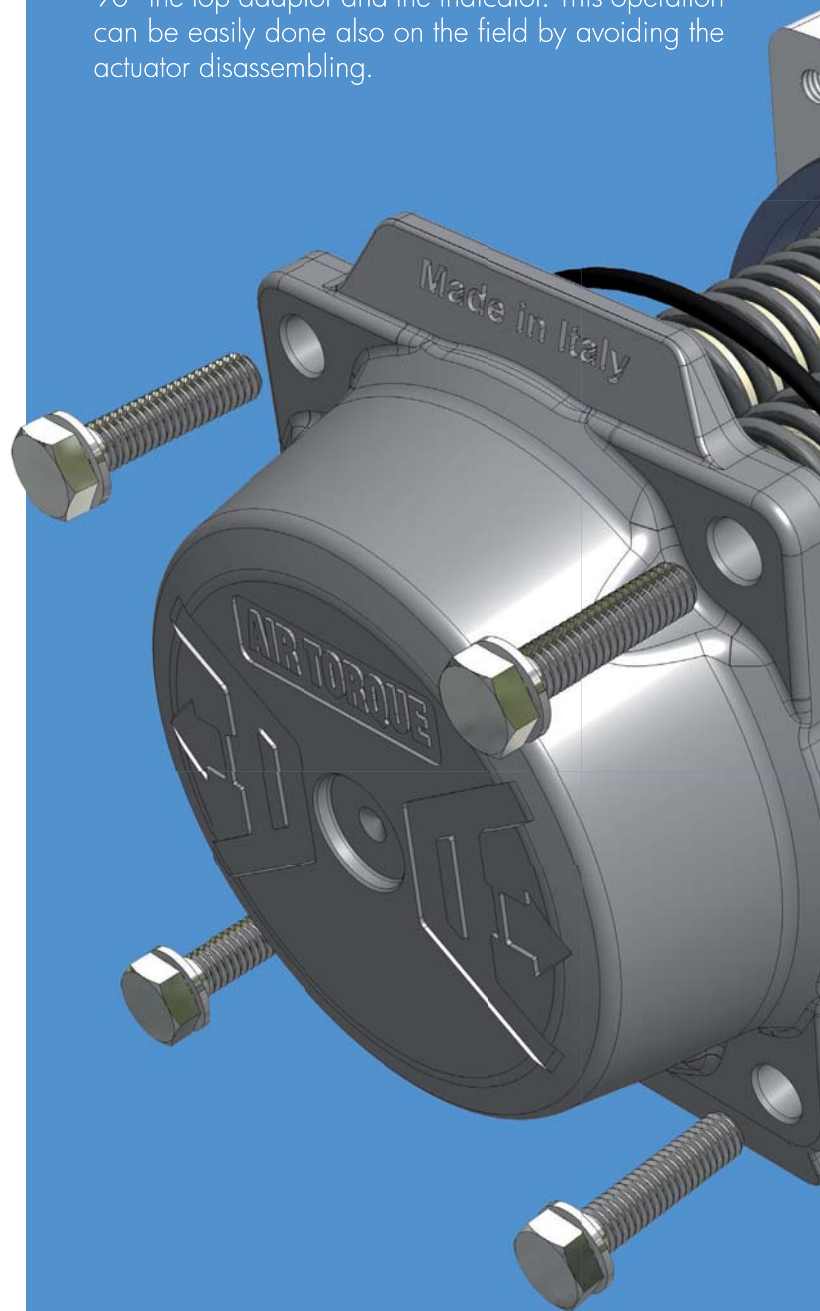

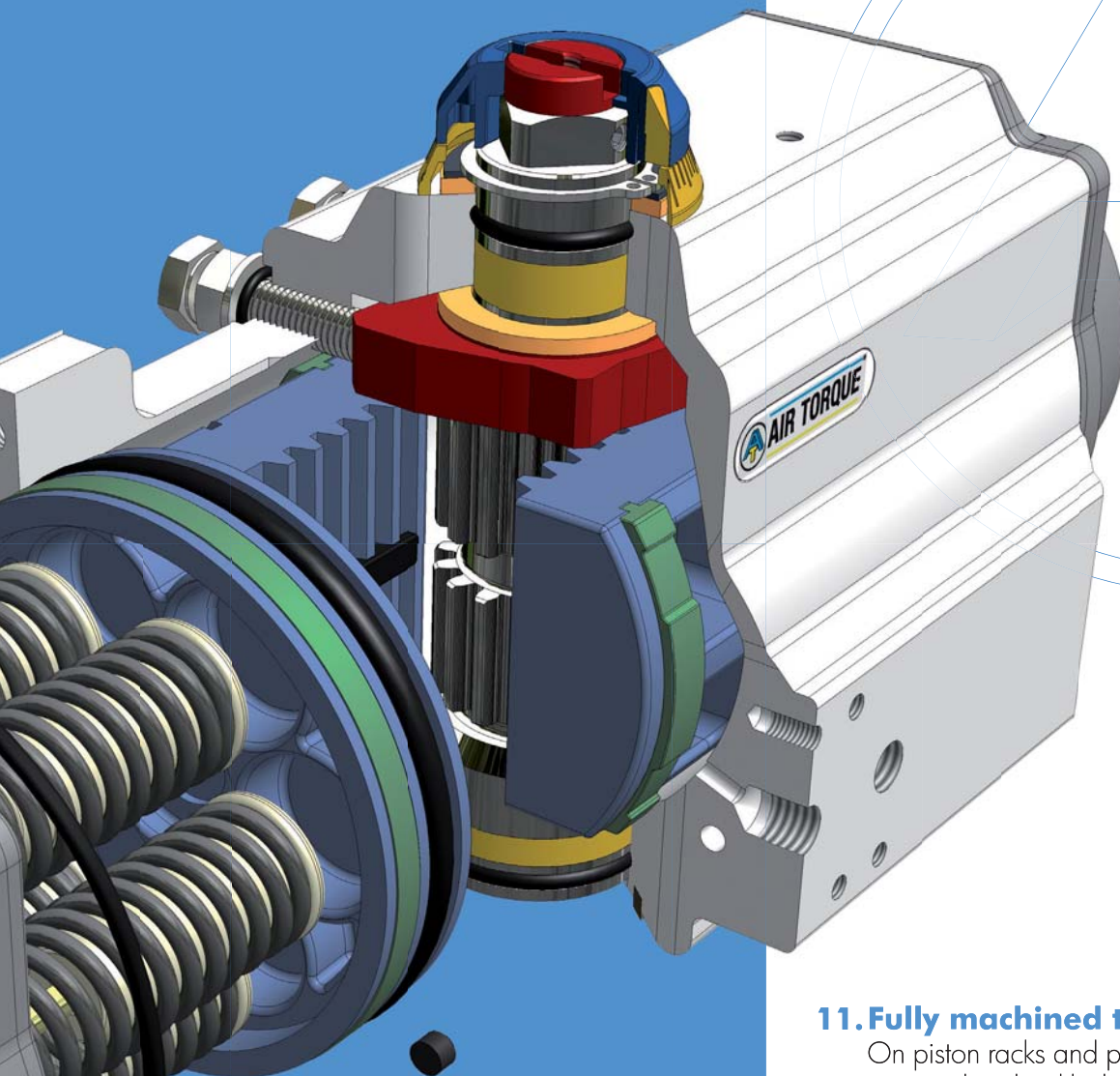

8. Multiple bearings and guide

Bearings on piston and racks for precise operation, low friction, high cycle life and piston guides preventing shaft blowout.

9. Modular preloaded springs

Cartridge design in high grade coated steel for simple range versatility, greater safety and corrosion resistance.

10. Electroless nickel-plated drive-shaft

Blow-out proof, bearing guided for improved safety and maximum cycle life.

11. Fully machined teeth

On piston racks and pinion shaft for accurate positioning, low backlash and maximum engagement resulting in overall efficient operation.

12. Selected and high quality bearings and seals

Provide a wide operating temperature range, low friction and high cycle life.

13. Fasteners

Stainless steel fasteners for long term corrosion resistance.

14. Full compliance

To specifications ISO 5211, DIN 3337 and VDI/VDE 3845 providing the product interchangeability and the easiest valve automation and accessories installation.

15. Product Identity

Plastic insert with Air Torque logo and unique patented design.

PRODUCT RANGE

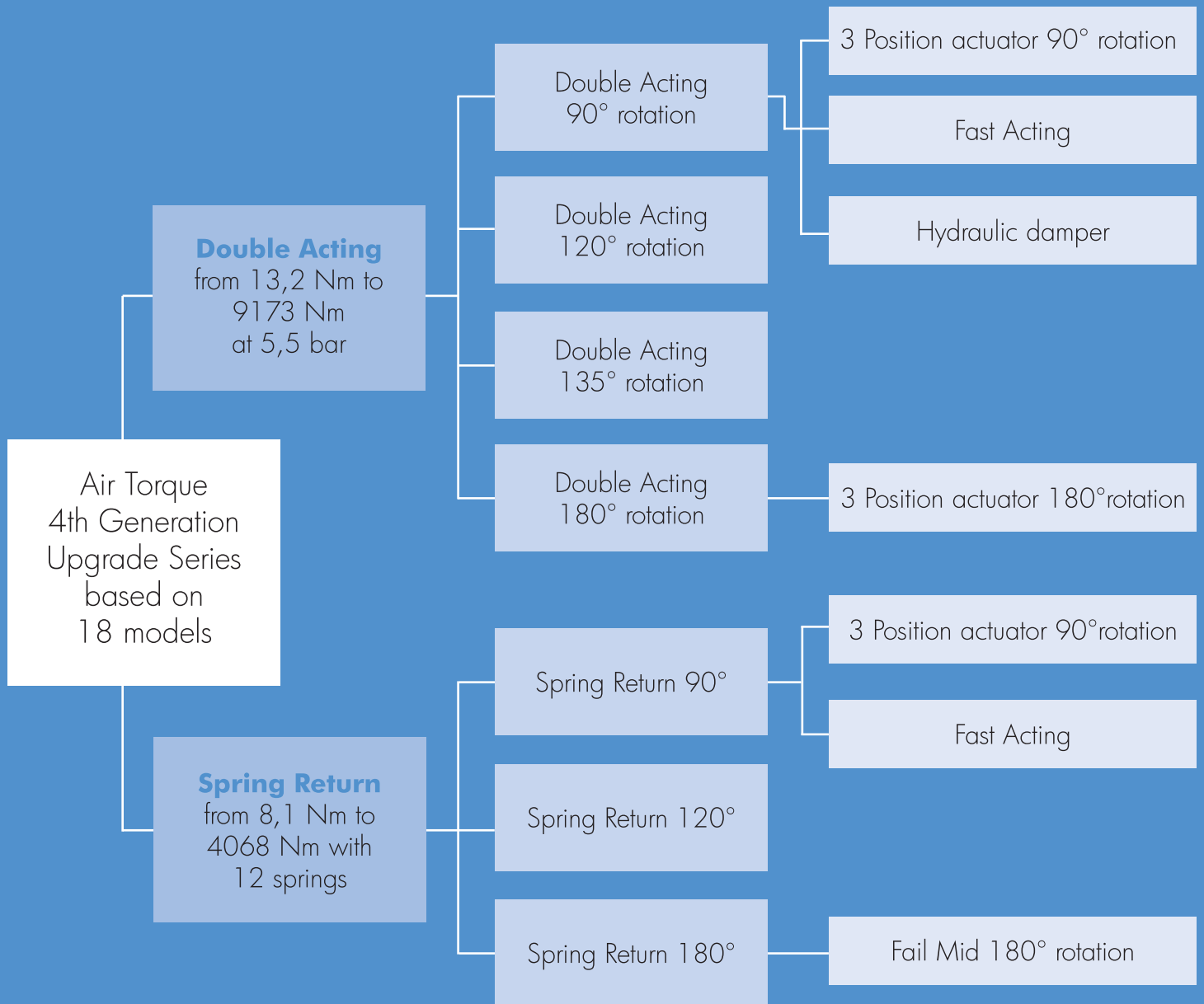

THE PRODUCT RANGE INCLUDES ALSO THE FOLLOWING OPTIONS

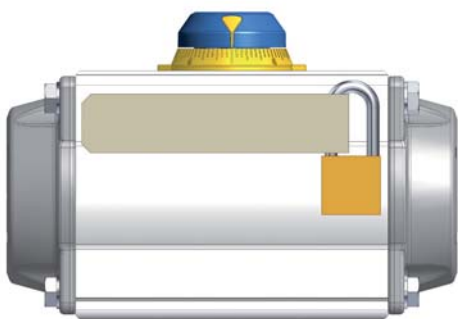

LOCK-OUT CAPABILITY

In order to permanently lock the actuator in position, the actuator can be supplied with a special locking device by using a padlock and therefore preventing unwanted operation.



100% TRAVEL STOP LIMITATION

When a stroke of less than 90° is required e.g. 1°, 5°, 10°, 25°, 50°, 70° and the standard adjustment is not suitable, the actuator can be supplied with special bolts in both End-Caps to allow stroke adjustment or limitation from 0° to 90° according to customer requirements.

1. Operating media

Dry or lubricated air, inert/non-corrosive gases provided that they are compatible with the internal actuator parts

2. Supply pressure

For Double Acting and Spring Return actuators the maximum supply pressure is up to 8 bar (116 PSI), the minimum supply pressure is 2.5 bar (36 PSI).

3. Working Temperature

- Standard actuator construction suitable from -40°C (-40°F) to $+80^{\circ}\text{C}$ ($+176^{\circ}\text{F}$)
- High temperature – HT – actuator construction suitable from -15°C ($+5^{\circ}\text{F}$) to $+150^{\circ}\text{C}$ ($+302^{\circ}\text{F}$)
- Extreme low temperature – LLT – actuator construction suitable from -55°C (-67°F) to $+80^{\circ}\text{C}$ ($+176^{\circ}\text{F}$)

4. Lubrication

Actuators are factory lubricated for life under normal operating conditions.

The standard lubricant is suitable for use from -40°C (-40°F) to $+80^{\circ}\text{C}$ ($+176^{\circ}\text{F}$)

5. Installation

Actuator suitable both for indoor and outdoor installation.

6. Protection and Corrosion resistance

Air Torque actuators are available in 6 different protection levels suitable for different environmental conditions. For severe duties select from the protection level table or contact AIR TORQUE.

7. Actuator selection and Marking

To have a correct actuator selection, the operating conditions have to be evaluated and defined; they will be marked on the actuator identification label.

ACTUATOR FUNCTION and ROTATION

The standard actuator rotation is clockwise to close, a counter-clockwise rotation is achieved when port 2 is pressurized. Non standard actuator rotation is counter-clockwise to close, a clockwise rotation is achieved when port 2 is pressurized. See the technical data-sheet for details.

Double Acting operation function (standard rotation) TOP View:

Air supplied to Port 2 forces the pistons towards the actuator end caps, with the exhaust air exiting from Port 4, a counter-clockwise rotation is achieved.

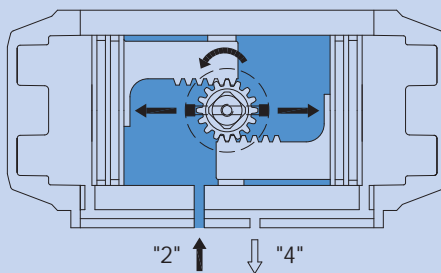

Air supplied to Port 4 forces the pistons inward, exhaust air exits from Port 2, a clockwise rotation is achieved.

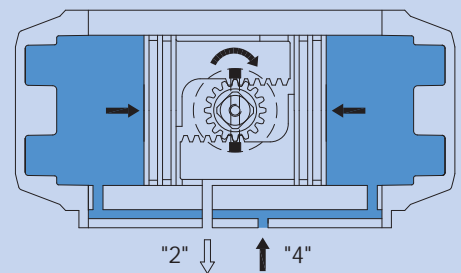

Single Acting operation function (standard rotation) TOP View:

Air supplied to Port 2 forces the pistons toward the actuator end caps, compressing the springs, with the exhaust air exiting from Port 4, a counter clockwise rotation is achieved.

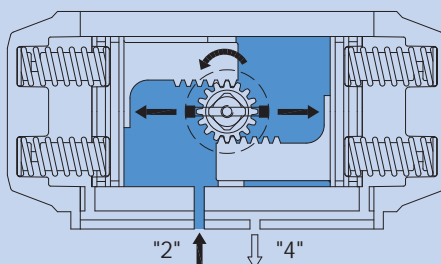

The loss of air pressure (air or electric failure) at Port 2 allows the springs to force the pistons inward with the exhaust air exiting from Port 2, a clockwise rotation is achieved.

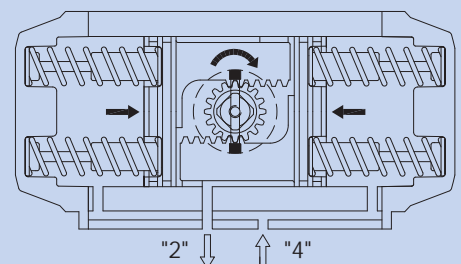

POSITION INDICATOR AND TOP ADAPTOR

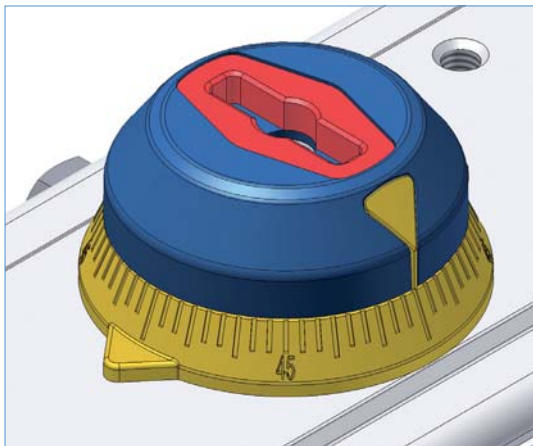

Options available for AT045U to AT101U

Standard position indicator **with stainless steel insert** for ancillary driving/attachment for a more precise and stable coupling with ancillary stem. A graduated ring is fitted, as a standard, under the position indicator in order to have an accurate position indication.

Optional indicators for direct mounting of sensors (P+F, IFM, etc.) and mechanical limit-switches

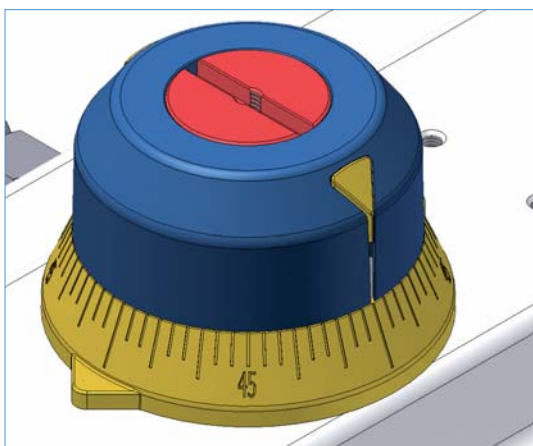
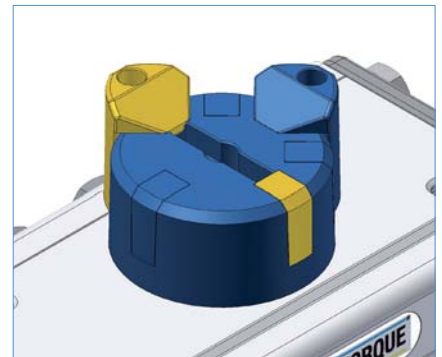
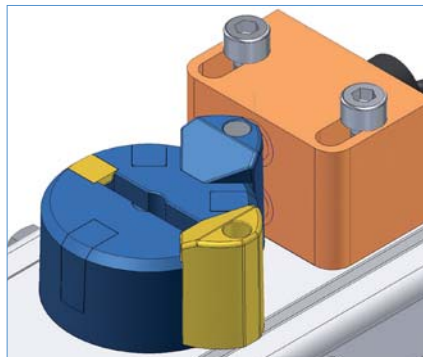
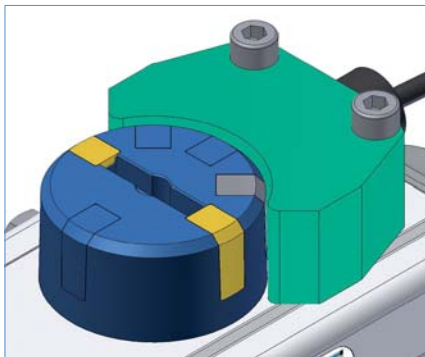

Options available for AT201U to AT1001U

Standard position indicator **with aluminum top adaptor** for ancillary driving/attachment for a more precise and stable coupling with ancillary stem. A graduated ring is fitted, as a standard, under the position indicator in order to have an accurate position indication.

Optional indicators for direct mounting of sensors (P+F, IFM, etc.) and mechanical limit-switches

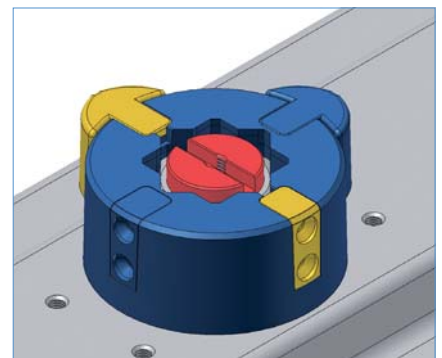
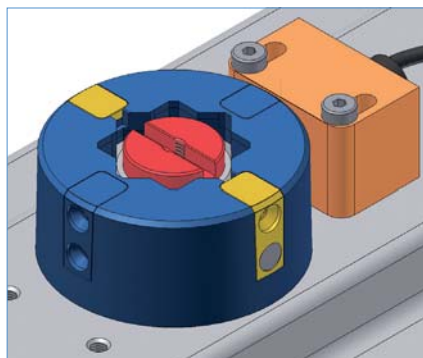
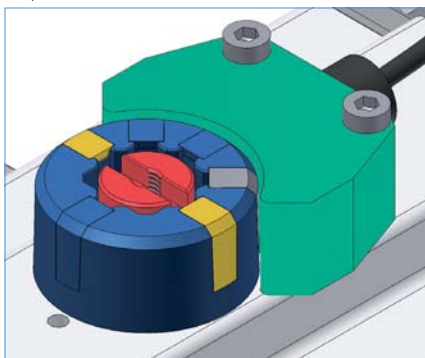

In line and across line actuator installation versatility

The patented design of the top adaptor in combination with the position indicator permits to easily achieve the right actuator/valve position indication since both can be easily fitted in any 45° position. Therefore during the valve automation it is not necessary to reassemble the drive shaft in order to achieve the correct position indication.

The top adaptor is suitable and available for any drive shaft connections like single square (diagonal and parallel), double square, head flat or key head.

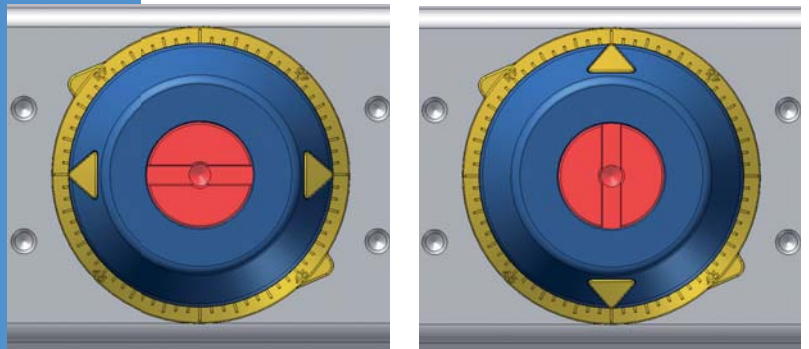
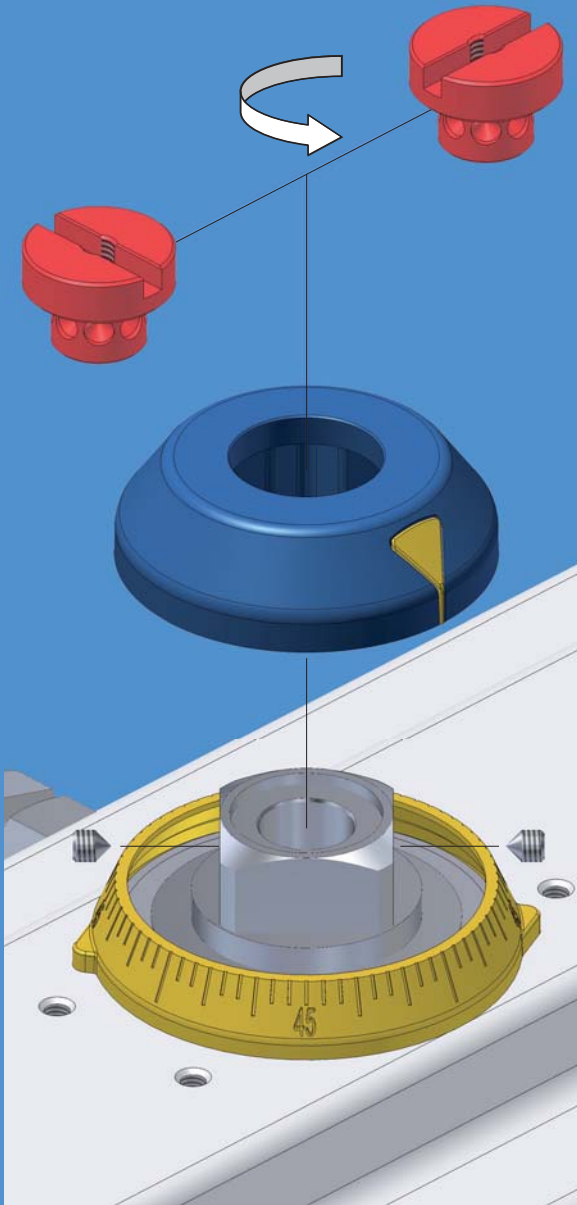

Actuator in close position and IN LINE installation

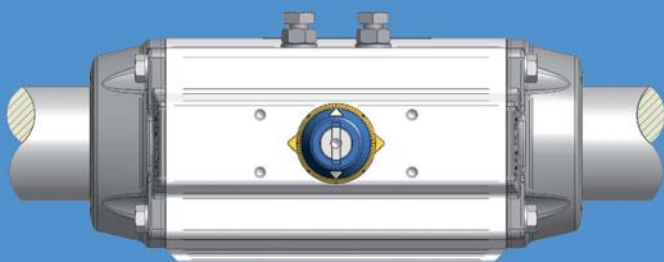

Actuator in close position and ACROSS LINE installation (Top adaptor and position indicator 90° rotated)

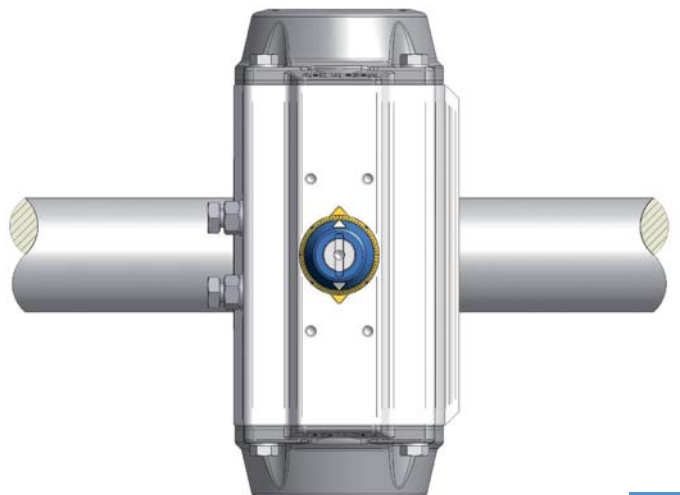

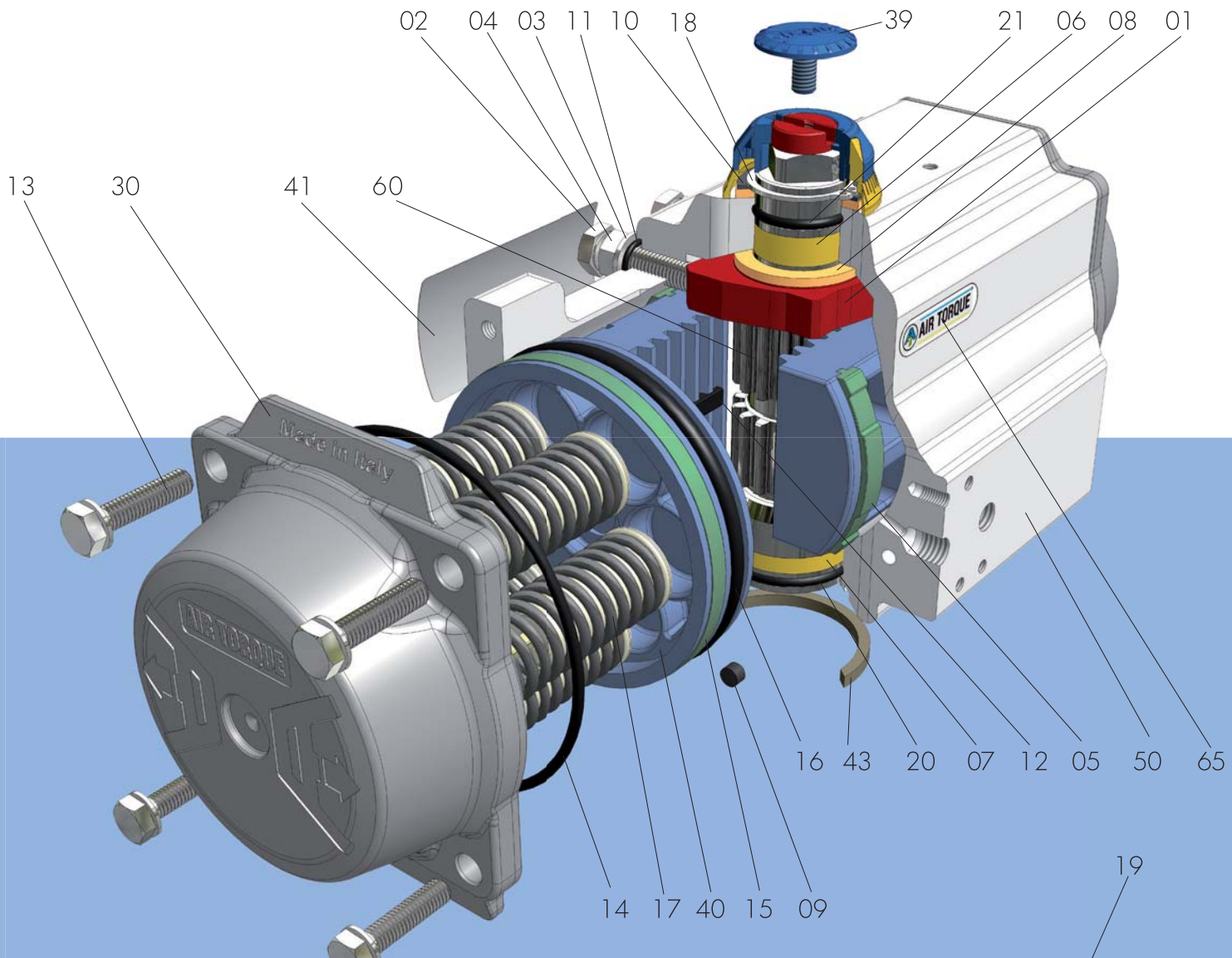

Spring for AT045U ÷ AT051U

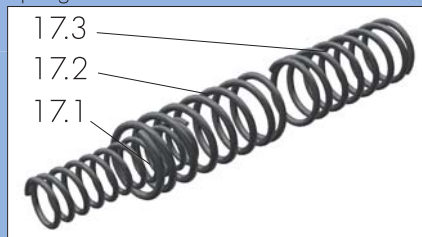

Spring cartridge for AT101U ÷ AT1001U

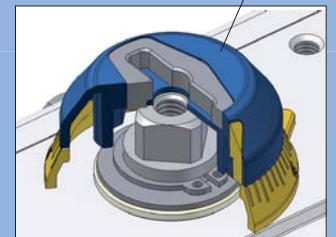

PART N°	Spare Parts	UNIT Q.TY / NOTE	PART DESCRIPTION	STANDARD MATERIAL
01		1 NA for AT045U	OCTI-CAM (Stop arrangement)	Stainless Steel (only for AT051U ÷ AT301U) Carbon Steel / Nodular Cast Iron, zinc coated
02		2 NA for AT045U	STOP CAP SCREW	Stainless Steel
02.1		2 only for AT1001U	SPRING CLIP (Anti-BlowOut Stop Screw)	Stainless Steel
03		2 NA for AT045U	WASHER	Stainless Steel
04		2 NA for AT045U	NUT (Stop screw)	Stainless Steel
05	○	2 for AT1001U	BEARING (Piston back)	High-grade polymers
06	○	1	BEARING (Pinion top)	High-grade polymers
07	○	1	BEARING (Pinion bottom)	High-grade polymers
08	○	2 1 Pc. for AT045U	THRUST BEARING (Pinion)	High-grade polymers
09	○ □	2	PLUG	M-NBR / Silicone
09.1	○ □	2 for AT801U ÷ AT1001U	"O-RING" PLUG	M-NBR / Silicone
10		1	THRUST WASHER (Pinion)	Stainless Steel
11	○ □	2 NA for AT045U	"O" RING (Stop screw)	M-NBR
12		2 NA for AT045U	PISTON GUIDE	High-grade polymers

○ Parts included in Complete spare parts kit

□ Parts included in "O" ring spare parts kit

AT801 U

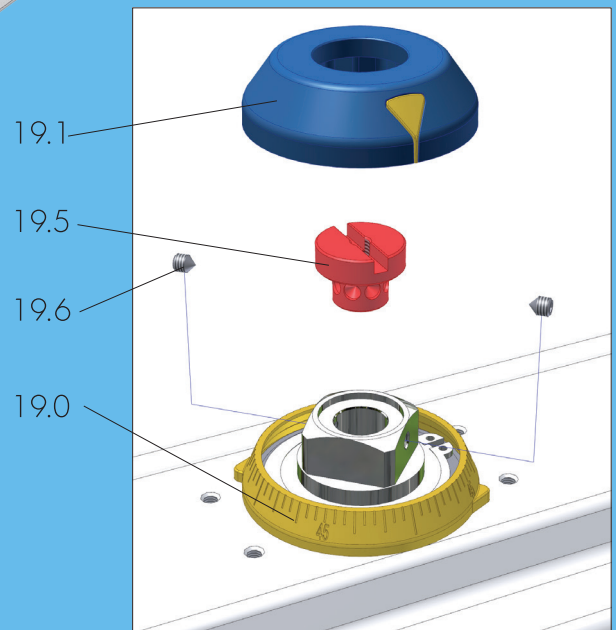
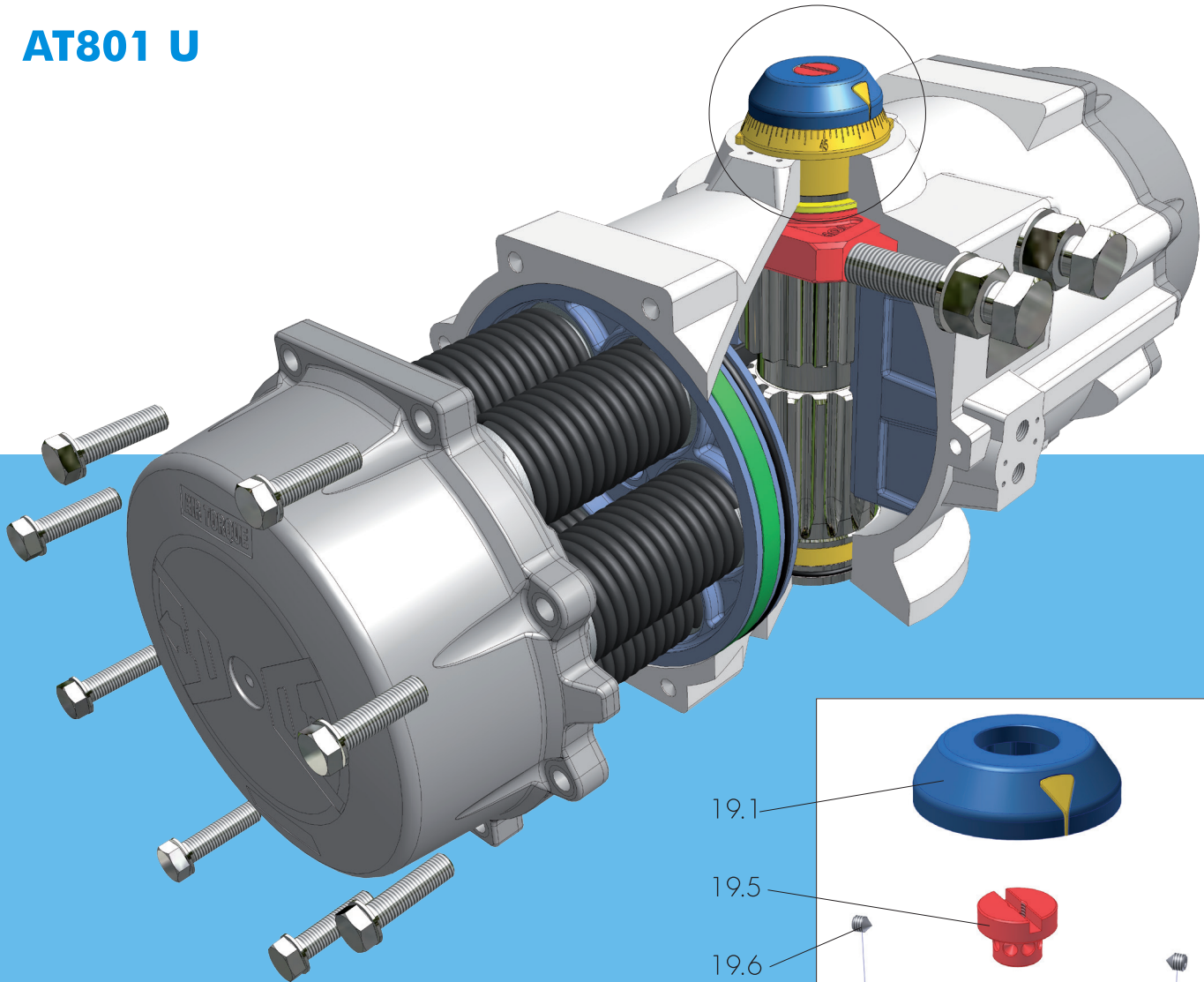

PART N°	Spare Parts	UNIT Q.TY / NOTE	PART DESCRIPTION	STANDARD MATERIAL
13		8 for AT045U ÷ AT651U	CAP SCREW (End cap)	Stainless Steel
		12 for AT701U ÷ AT751U		
		16 for AT801U ÷ AT1001U		
13.1		16 for AT1001U	WASHER (Cap Screw end cap)	Stainless Steel
14	○ □	2	"O" RING (End cap)	M-NBR
15	○	2	BEARING (Piston head)	High-grade polymers
16	○ □	2	"O" RING (Piston)	M-NBR
17		max. 12 for AT101U ÷ AT1001U	SPRING (Cartridge)	SiCr Spring alloy Steel coated
17.1		max. 2 for AT045U	SPRING	
17.2			SPRING	
17.3		max. 4 for AT051U	SPRING	
18		1	SPRING CLIP (Pinion)	Spring Steel, ENP
19		1 for AT045U ÷ AT101U	POSITION INDICATOR	High-grade polymers / Stainless Steel
19.0		1	GRADUATED RING	High-grade polymers
19.1		1 NA for AT045U ÷ AT101U	POSITION INDICATOR	High-grade polymers
19.5		1 NA for AT045U ÷ AT101U	TOP ADAPTOR	Extruded Aluminium alloy, anodized
19.6		2 NA for AT045U ÷ AT101U	HEX. SOCKET SCREW (Top Adaptor)	Stainless Steel

○ Parts included in Complete spare parts kit

□ Parts included in "O" ring spare parts kit



AT1001 U

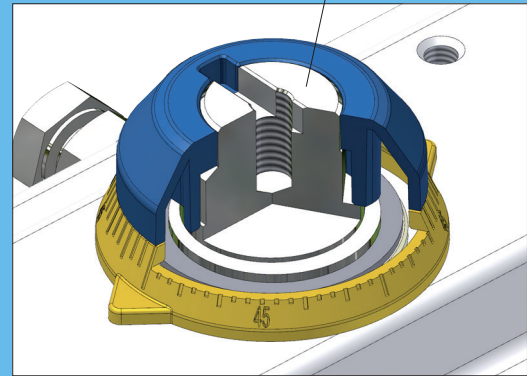
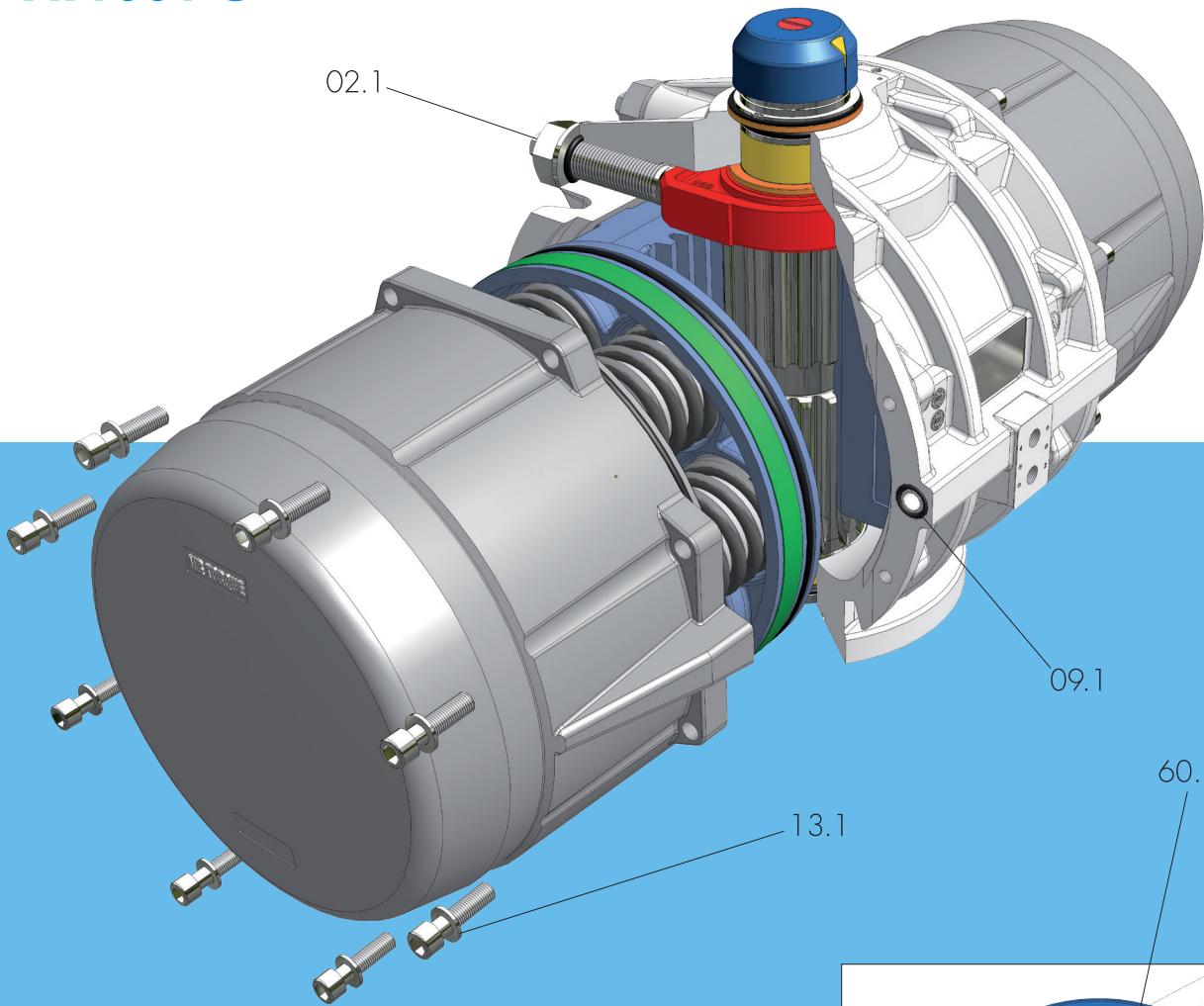

PART N°	Spare Parts	UNIT Q.TY / NOTE	PART DESCRIPTION	STANDARD MATERIAL
20	<input type="radio"/> <input type="checkbox"/>	1	"O" RING (Pinion bottom)	M-NBR
21	<input type="radio"/> <input type="checkbox"/>	1	"O" RING (Pinion top)	M-NBR
30		2	END CAP	Pressure Die Cast Aluminium alloy, anodized and coated Cast Aluminium alloy, anodized and coated (for AT1001U)
39		1	CAP SCREW (Indicator)	High-grade polymers
40		2	PISTON	Pressure Die Cast Aluminium alloy, anodized Cast Aluminium alloy, anodized (for AT1001U)
41		1	ACTUATOR IDENTIFICATION LABEL	Polyester-Silver
42		2	only for AT045U, AT751U and AT1001U END CAP LABEL	Polyester-Silver
43		1	SPIGOT (Only on request)	Extruded Aluminium alloy, anodized
50		1	BODY	Extruded Aluminium alloy, coated Cast Aluminium alloy, coated (for AT801U and AT1001U)
60		1	DRIVE SHAFT	Extruded Aluminium alloy, anodized (for AT045U and AT1001U) Steel, ENP
60.1		1	only for protection level "E" and "F" INTEGRAL DRIVE SHAFT	Stainless Steel, ENP
65		1	PLASTIC INSERT	High-grade polymers

Parts included in Complete spare parts kit

Parts included in "O" ring spare parts kit

DIMENSIONS AND TECHNICAL DATA



AIR CONNECTION VDI/VDE 3845

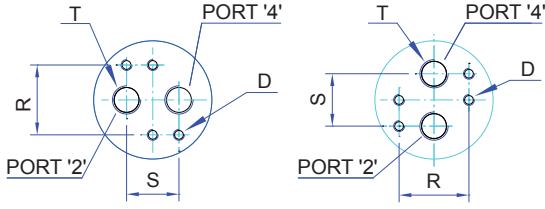

For models AT045U + AT751U

For models AT801U - AT1001U

BOTTOM VIEW ISO 5211

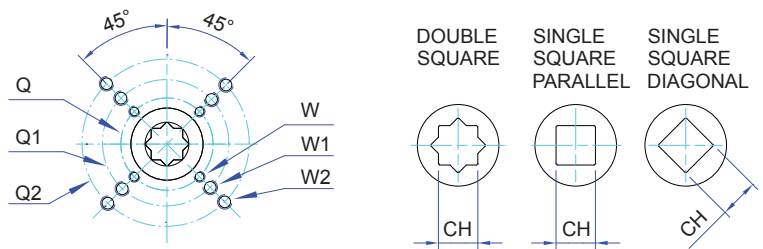

DIMENSIONS IN mm

ACTUATOR MODEL	AT045U D/S	AT051U D/S	AT101U D/S	AT201U D/S	AT251U D/S	AT301U D/S	AT351U D/S	AT401U D/S	AT451U D/S	AT501U D/S	AT551U D/S	AT601U D/S	AT651U D/S	AT701U D/S	AT751U D/S	AT801U D/S	AT1001U D/S					
A	118	135,5	153,5	203,5	241	259	304	333	394,5	422,5	474	528	605	710	812	855	950					
B	66	69	85	102	115	127	145	157	177	196	220,5	245	298,5	330	383	410	518					
C	62	71	84,5	93	106	118,5	136	146,5	166	181	200	221,5	262	330	371	418	528					
D	M5x8	M5x8	M5x8	M5x8	M5x8	M5x8	M5x8	M5x8	M5x8	M5x8	M5x8	M5x8	M6x10	M6x10	M6x10	M6x10	M6x10					
E	M5x8	M5x8	M5x8	M5x8	M5x8	M5x8	M5x8	M5x8	M5x8	M5x8	M5x8	M5x8	M5x8	M5x8	M5x8	M5x8	M6x10					
F	80	80	80	80	80	80	80	80	80	80	130	130	130	130	130	130	200					
G	30	30	30	30	30	30	30	30	30	30	30	30	30	30	30	30	50					
N	11	11	11	17	17	17	27	27	27	27	36	36	36	36	36	36	36					
P	15/20	20	20	20	20	20	30	30	30	30	50	50	50	50	50	50	80					
R	32	32	32	32	32	32	32	32	32	32	32	32	45	45	45	45	45					
S	24	24	24	24	24	24	24	24	24	24	24	24	40	40	40	40	40					
T ISO 228	1/8"	1/8"	1/8"	1/8"	1/8"	1/4"	1/4"	1/4"	1/4"	1/4"	1/4"	1/4"	3/8"	1/2"	1/2"	1/2"	1/2"					
Ø Z1	42	42	42	42	42	42	58	58	67,5	67,5	80	80	115	115	115	115	135					
ISO Flange	F04	F04	F05 + F07	F05 + F07	F05 + F07	F07 + F10	F07 + F10	F07 + F10	F10 + F12	F10 + F12	F14	F14	F16	F16	F16	F16 + F25	F16 + F25 + F30					
Q	42	42	50	50	50	70	70	70	102	102	140	140	165	165	165	165	165					
Q1	-	-	70	70	70	102	102	102	125	125	-	-	-	-	-	254	254					
Q2	-	-	-	-	-	-	-	-	-	-	-	-	-	-	-	-	298					
W	M5	M5	M6	M6	M6	M8	M8	M8	M10	M10	M16	M16	M20	M20	M20	M20	M20					
W1	-	-	M8	M8	M8	M10	M10	M10	M12	M12	-	-	-	-	-	M16	M16					
W2	-	-	-	-	-	-	-	-	-	-	-	-	-	-	-	-	M20					
OPTIONAL ISO Flange	F03	F03 + F05	F03 + F05	F05	F04 + F07	F04 + F07	F07	F05 + F07	F07	F10	F10	F12	F12	F10 + F12	F10 + F12	F12	F12	F14	F14	F16 + F25	F25	F30
CH x I min.	D	-	9 x 11	9 x 11	11 x 12	11 x 12	14 x 16	14 x 16	17 x 19	22 x 24	22 x 24	22 x 24	22 x 24	27 x 29	27 x 29	55 x 59	55 x 59	75 x 80				
		-	11 x 12	14 x 16	14 x 16	14 x 16	17 x 19	22 x 24	27 x 29	27 x 29	27 x 29	36 x 39	36 x 39	46 x 49	46 x 49	-	-	-				
	DS	9 x 11	11 x 12	11 x 12	14 x 16	17 x 19	17 x 19	17 x 19	17 x 19	22 x 24	27 x 29	27 x 29	27 x 29	27 x 29	36 x 39	36 x 39	46 x 49	46 x 49	55 x 59			
		11 x 12	-	14 x 16	17 x 16	-	22 x 24	22 x 24	27 x 29	-	-	-	36 x 39	36 x 39	46 x 49	46 x 49	55 x 59	55 x 59	75 x 80			

TECHNICAL DATA (METRIC UNIT)

METRIC	MODEL TYPE	AT045U		AT051U		AT101U		AT201U		AT251U		AT301U		AT351U		AT401U		AT451U		AT501U		AT551U		AT601U		AT651U		AT701U		AT751U		AT801U		AT1001U	
		D	S	D	S	D	S	D	S	D	S	D	S	D	S	D	S	D	S	D	S	D	S	D	S	D	S	D	S	D	S	D	S		
Opening Time (Sec.)		0,15	0,2	0,2	0,25	0,25	0,3	0,3	0,4	0,4	0,5	0,5	0,7	0,7	0,9	0,9	1,2	1,2	1,5	1,5	1,8	2	2,4	2,7	3,5	3,5	4,1	4	4,5	5	6	6	7,5	8	10
Closing Time (Sec.)		0,2	0,25	0,25	0,3	0,3	0,35	0,35	0,5	0,5	0,6	0,6	0,9	0,8	1,1	1,1	1,4	1,4	1,8	1,7	2,1	2,2	2,8	3,2	4	4	4,6	4,5	5	6	7	7	8,5	9	11
Air Volume Opening (L)		0,06		0,09		0,16		0,31		0,51		0,71		1,19		1,54		2,41		3,14		4,26		5,94		10		14,5		20		25		49	
Air Volume Closing (L)		0,1		0,15		0,26		0,49		0,78		1,11		1,8		2,34		3,78		4,92		6,89		9,46		15,2		21,4		33		40		84	
Approximate Weight (Kg)		0,75	0,9	1,1	1,3	1,6	1,8	2,7	3	3,8	4,4	5,2	6	8,1	9,4	10	12,4	14,2	17,1	17,8	21,4	24,3	32,7	34,3	43,6	54,6	69	76,3	95,5	118	150	127	169	170	238

Note: (A) The above moving times of the actuator are obtained in the following test conditions:

For model AT045U ÷ AT501U : (1) Room Temperature, (2) Actuator Stroke 90°, (3) Solenoid Valve with Orifice Of 4 mm and a flow capacity Qn 400L/min., (4) Inside pipe diameter 8 mm, (5) Medium clean air, (6) Air supply pressure 5,5 bar (79,75 Psi), (7) Actuator without external resistance load.

For model AT551U ÷ AT1001U : (1) Room Temperature, (2) Actuator Stroke 90°, (3) Solenoid Valve with Orifice Of 11 mm and a flow capacity Qn 6000L/min., (4) Inside pipe diameter 11 mm, (5) Medium clean air, (6) Air supply pressure 5,5 bar (79,75 Psi), (7) Actuator without external resistance load.

Cautions: obviously on the field applications when one or more of the above parameter are different, the moving time will be different.



FRONT VIEW

SIDE VIEW

TOP DETAIL

AT045U

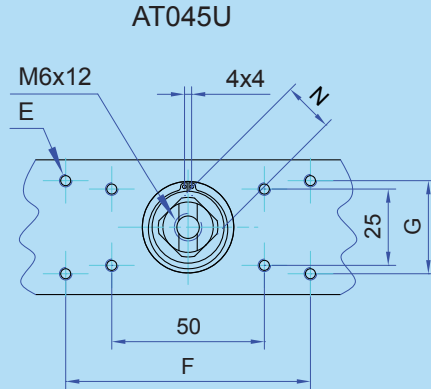
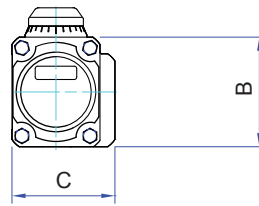
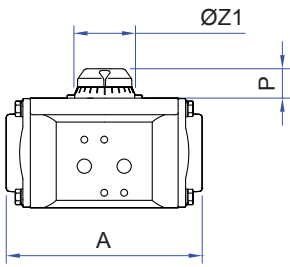

AT051U ÷ AT651U

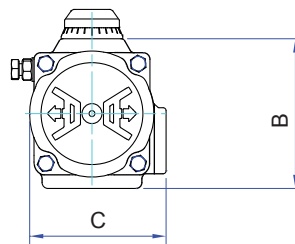
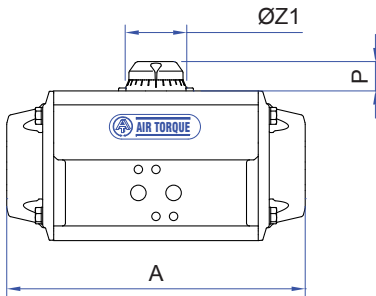

AT051U ÷ AT101U

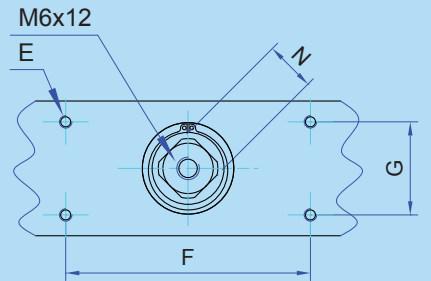

AT701U ÷ AT751U

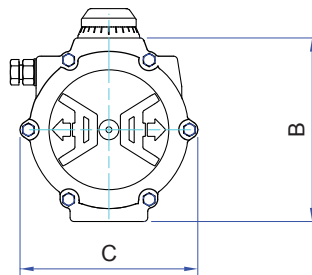
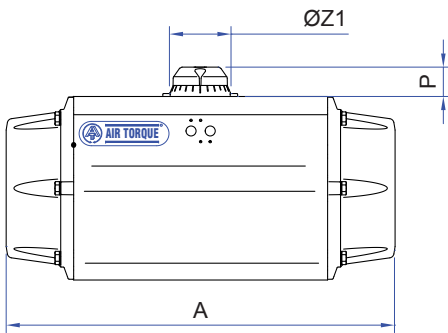

AT201U ÷ AT751U

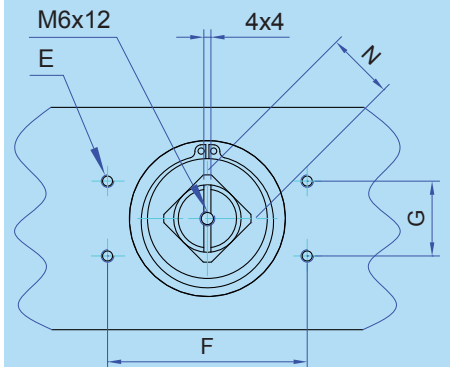

AT801U

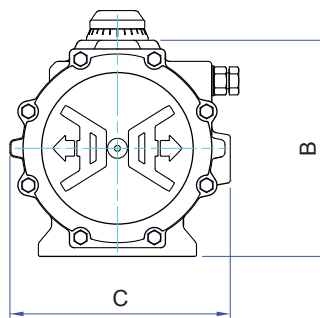
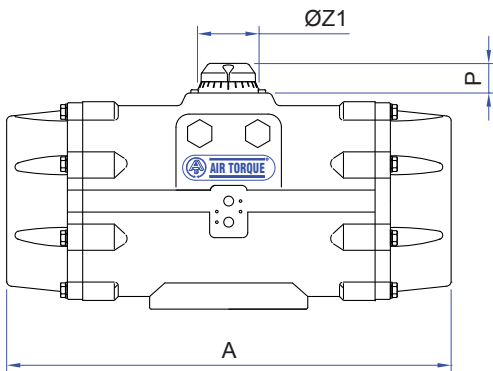

AT801U ÷ AT1001U

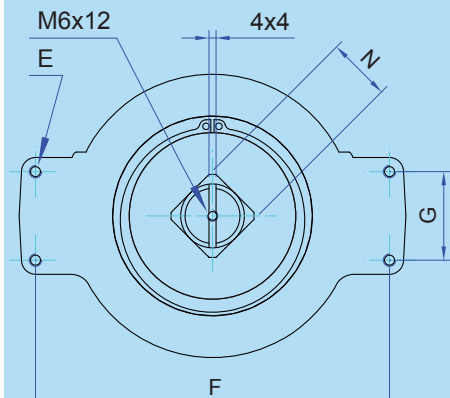

AT1001U

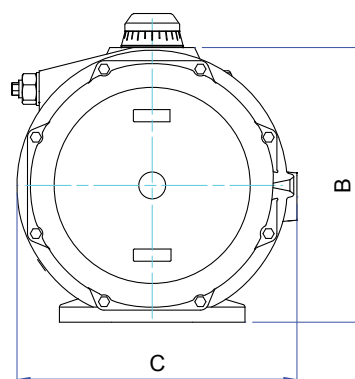
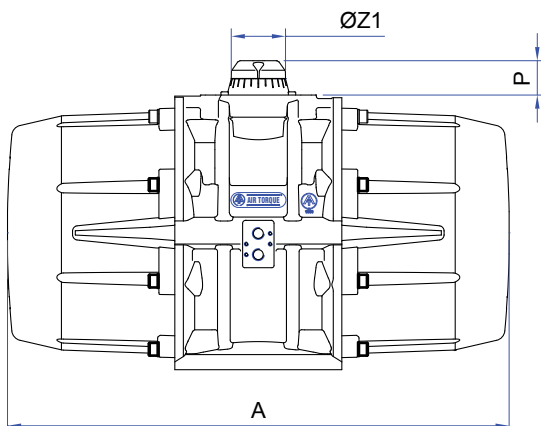

AIR CONNECTION VDI/VDE 3845

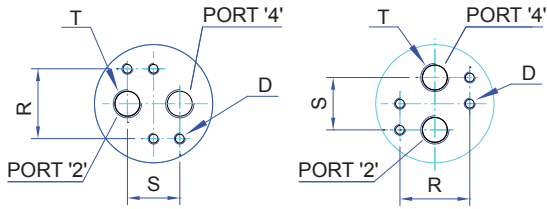

For models AT045U + AT751U

For models AT801U - AT1001U

BOTTOM VIEW ISO 5211

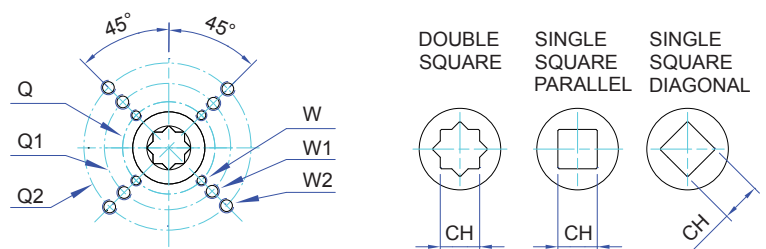

DIMENSIONS IN INCH

ACTUATOR MODEL	AT045U D/S	AT051U D/S	AT101U D/S	AT201U D/S	AT251U D/S	AT301U D/S	AT351U D/S	AT401U D/S	AT451U D/S	AT501U D/S	AT551U D/S	AT601U D/S	AT651U D/S	AT701U D/S	AT751U D/S	AT801U D/S	AT1001U D/S						
A	4,65	5,33	6,04	8,01	9,49	10,20	11,97	13,11	15,53	16,63	18,66	20,79	23,82	27,95	31,97	33,66	37,40						
B	2,60	2,72	3,35	4,02	4,53	5,00	5,71	6,18	6,97	7,72	8,68	9,65	11,75	12,99	15,08	16,14	20,39						
C	2,44	2,80	3,33	3,66	4,17	4,67	5,35	5,77	6,54	7,13	7,87	8,72	10,31	12,99	14,61	16,46	20,79						
D	M5x0,31	M5x0,31	M5x0,31	M5x0,31	M5x0,31	M5x0,31	M5x0,31	M5x0,31	M5x0,31	M5x0,31	M5x0,31	M5x0,31	M6x0,39	M6x0,39	M6x0,39	M6x0,39	M6x0,39						
E	M5x0,31	M5x0,31	M5x0,31	M5x0,31	M5x0,31	M5x0,31	M5x0,31	M5x0,31	M5x0,31	M5x0,31	M5x0,31	M5x0,31	M5x0,31	M5x0,31	M5x0,31	M5x0,31	M6x0,39						
F	3,15	3,15	3,15	3,15	3,15	3,15	3,15	3,15	3,15	3,15	5,12	5,12	5,12	5,12	5,12	5,12	7,87						
G	1,18	1,18	1,18	1,18	1,18	1,18	1,18	1,18	1,18	1,18	1,18	1,18	1,18	1,18	1,18	1,18	1,97						
N	0,43	0,43	0,43	0,67	0,67	0,67	1,06	1,06	1,06	1,06	1,42	1,42	1,42	1,42	1,42	1,42	1,42						
P	0,59/0,79	0,79	0,79	0,79	0,79	0,79	1,18	1,18	1,18	1,18	1,97	1,97	1,97	1,97	1,97	1,97	3,15						
R	1,26	1,26	1,26	1,26	1,26	1,26	1,26	1,26	1,26	1,26	1,26	1,26	1,77	1,77	1,77	1,77	1,77						
S	0,94	0,94	0,94	0,94	0,94	0,94	0,94	0,94	0,94	0,94	0,94	0,94	1,57	1,57	1,57	1,57	1,57						
T * ISO 228	1/8"	1/8"	1/8"	1/8"	1/8"	1/4"	1/4"	1/4"	1/4"	1/4"	1/4"	1/4"	3/8"	1/2"	1/2"	1/2"	1/2"						
ØZ1	1,65	1,65	1,65	1,65	1,65	1,65	2,28	2,28	2,66	2,66	3,15	3,15	4,53	4,53	4,53	4,53	5,31						
ISO Flange	F04	F04	F05 + F07	F05 + F07	F05 + F07	F07 + F10	F07 + F10	F07 + F10	F10 + F12	F10 + F12	F14	F14	F16	F16	F16	F16 + F25	F16 + F25 + F30						
Q	1,65	1,65	1,97	1,97	1,97	2,76	2,76	2,76	4,02	4,02	5,51	5,51	6,50	6,50	6,50	6,50	6,50						
Q1	-	-	2,76	2,76	2,76	4,02	4,02	4,02	4,92	4,92	-	-	-	-	-	10	10						
Q2	-	-	-	-	-	-	-	-	-	-	-	-	-	-	-	-	11,73						
W	M5	M5	M6	M6	M6	M8	M8	M8	M10	M10	M16	M16	M20	M20	M20	M20	M20						
W1	-	-	M8	M8	M8	M10	M10	M10	M12	M12	-	-	-	-	-	M16	M16						
W2	-	-	-	-	-	-	-	-	-	-	-	-	-	-	-	-	M20						
OPTIONAL ISO Flange	F03	F03 + F05	F03 + F05	F04 + F07	F04 + F07	F05	F05 + F07	F05 + F07	F10	F10	F12	F12	F10 + F12	F10 + F12	F12	F12	F14	F14	F14	F16 + F25	F25	F30	
CH x l min.	D	-	0,35 x 0,43	0,35 x 0,43	0,43 x 0,47	0,43 x 0,47	0,55 x 0,63	0,55 x 0,63	0,67 x 0,75	0,67 x 0,75	0,87 x 0,94	0,87 x 0,94	0,87 x 0,94	0,87 x 0,94	1,06 x 1,14	1,06 x 1,14	1,42 x 1,54	1,42 x 1,54	1,81 x 1,93	1,81 x 1,93	2,17 x 2,32	2,17 x 2,32	2,95 x 3,15
	DS	0,35 x 0,43	0,43 x 0,47	0,43 x 0,47	0,55 x 0,63	0,55 x 0,63	0,67 x 0,75	0,67 x 0,75	0,67 x 0,75	0,87 x 0,94	0,87 x 0,94	1,06 x 1,14	1,06 x 1,14	1,06 x 1,14	1,06 x 1,14	1,42 x 1,54	1,42 x 1,54	1,81 x 1,93	1,81 x 1,93	1,81 x 1,93	2,17 x 2,32	2,17 x 2,32	2,95 x 3,15

* NPT (ANSI B1-20-1) threads available on request.

TECHNICAL DATA (IMPERIAL UNIT)

IMPERIAL MODEL TYPE	AT045U		AT051U		AT101U		AT201U		AT251U		AT301U		AT351U		AT401U		AT451U		AT501U		AT551U		AT601U		AT651U		AT701U		AT751U		AT801U		AT1001U	
	D	S	D	S	D	S	D	S	D	S	D	S	D	S	D	S	D	S	D	S	D	S	D	S	D	S	D	S	D	S	D	S		
Opening Time (Sec.)	0,15	0,2	0,2	0,25	0,25	0,3	0,3	0,4	0,4	0,5	0,5	0,6	0,7	0,8	0,9	1,1	1,2	1,4	1,5	1,7	2	2,2	2,7	3,2	3,5	4	4	4,5	5	6	6	7,5	8	10
Closing Time (Sec.)	0,2	0,25	0,25	0,3	0,3	0,35	0,35	0,5	0,5	0,6	0,7	0,8	0,9	1,1	1,2	1,4	1,5	1,8	1,8	2,1	2,4	2,8	3,5	4	4,1	4,6	4,5	5	6	7	7	8,5	9	11
Air Volume Opening (Cu. In.)	3,66		5,5		9,8		18,9		31,1		43,3		72,6		94		147,1		191,6		260		362,5		610,2		884,8		1220		1526		2990	
Air Volume Closing (Cu. In.)	6,1		9,2		15,9		29,9		47,6		67,7		109,8		142,8		230,7		300,2		420,5		577,3		927,6		1305		2014		2441		5126	
Approximate Weight (Lbs)	1,65	1,98	2,4	2,9	3,5	4,0	6,0	6,6	8,4	9,7	11,5	13,2	17,9	20,7	22,0	27,3	31,3	37,7	39,2	47,2	53,6	72,1	75,6	96,1	120	152	168	211	260	331	280	371	375	525

Note: (A) The above moving times of the actuator are obtained in the following test conditions:

For model AT045U ÷ AT501U: (1) Room Temperature, (2) Actuator Stroke 90°, (3) Solenoid Valve with Orifice Of 4 mm and a flow capacity Qn 400L/min., (4) Inside pipe diameter 8 mm, (5) Medium clean air, (6) Air supply pressure 5,5 bar (79,75 Psi), (7) Actuator without external resistance load.

For model AT551U ÷ AT1001U: (1) Room Temperature, (2) Actuator Stroke 90°, (3) Solenoid Valve with Orifice Of 11 mm and a flow capacity Qn 6000L/min., (4) Inside pipe diameter 11 mm, (5) Medium clean air, (6) Air supply pressure 5,5 bar (79,75 Psi), (7) Actuator without external resistance load.

Cautions: obviously on the field applications when one or more of the above parameter are different, the moving time will be different.

SPRING SET CONFIGURATION

AT045U configuration

Spring Set	Side B	Side A
	AT045U Spring type	AT045U Spring type
S1-1	1 (green)	1 (green)
S1-2	1 (green)	2 (red)
S2-2	2 (red)	2 (red)
S2-3	2 (red)	3 (black)
S3-3	3 (black)	3 (black)

AT051U configuration

Spring Set	Side B		Side A	
	AT051U Internal Spring type	AT051U External Spring type	AT051U Internal Spring type	AT051U External Spring type
S1	1 (green)	-----	-----	2 (black)
S2	-----	2 (black)	-----	2 (black)
S3	-----	2 (black)	-----	3 (red)
S4	-----	3 (red)	-----	3 (red)
S5	-----	3 (red)	1 (green)	2 (black)
S6	1 (green)	2 (black)	1 (green)	2 (black)
S7	1 (green)	2 (black)	1 (green)	3 (red)
S8	1 (green)	3 (red)	1 (green)	3 (red)

AT101U to AT1001U configuration

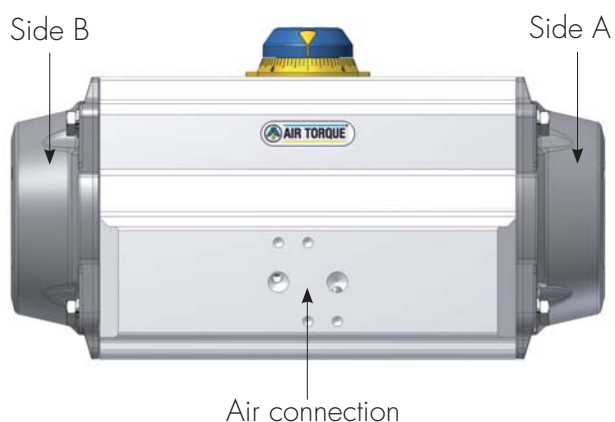
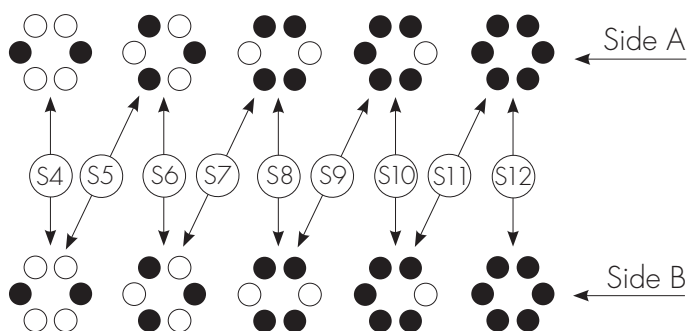

TYPICAL TORQUE CURVES FOR RACK PINION ACTUATORS

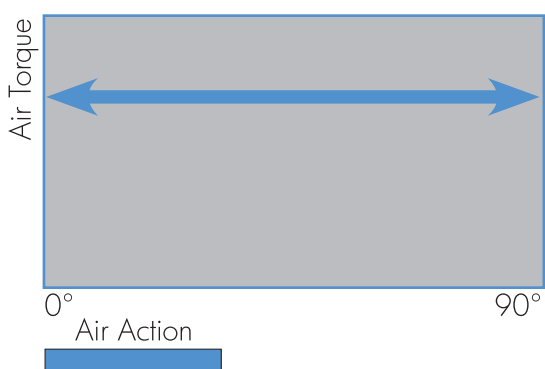

Torque output double acting

The double acting actuator has constant torque over the whole stroke, so that all that needs to be known for sizing is the maximum valve torque, which is multiplied by a safety factor (usually at least 25%-30% depending on the valve and service). The value thus obtained is then compared with figures in the minimum air pressure column in the actuator torque tables. After having found the same or nearest value (in excess), the suitable actuator model can be read from the column to the left.

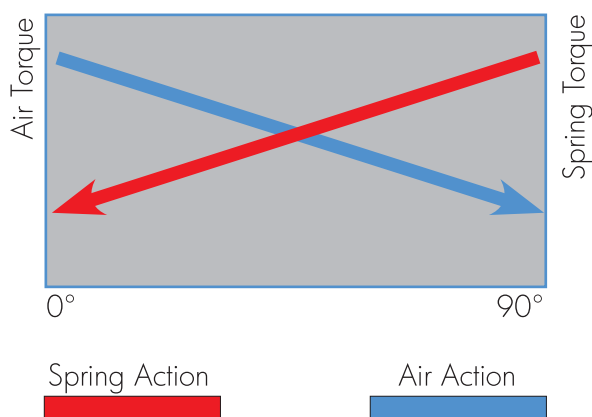

Torque output spring return

The spring return actuator has four different torque values: the air torques at 0° and 90° when it is pressurized, and the spring torques at 90° and 0° when the pressure is discharged. For a correct sizing, the torque curves of the actuator in both strokes have to be higher than the valve torque curves. Also for the spring return actuator sizing, the valve torques have to be multiplied by a safety factor (usually at least 25%-30% depending on the valve and service). The 4th Generation Line Upgrade Series are designed to give a balanced torque when the number of springs per side is equal to the air pressure supply in bar (for example 4 bar, 4 springs per side).

ACTUATOR INTERFACE FOR AUTOMATION

VDI/VDE3845 for ancillary attachment



VDI/VDE3845
for actuator pneu-
matic controls

ISO5211/DIN3337
for valve assembling



Spigot (on request)

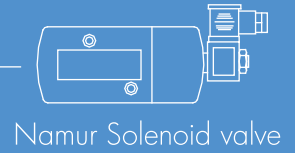
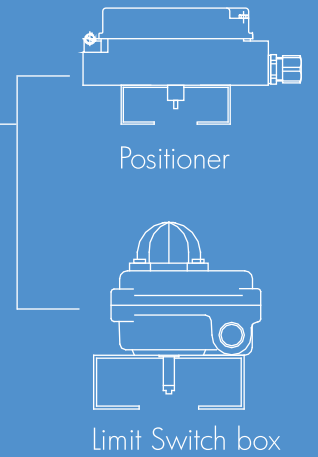

Namur Solenoid valve

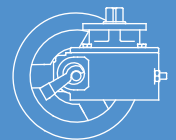

Dec clutchable gear box

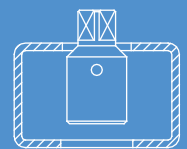

Mounting kits

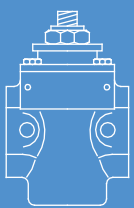

Plug valve



Ball valve

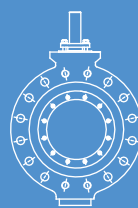

Butterfly valve

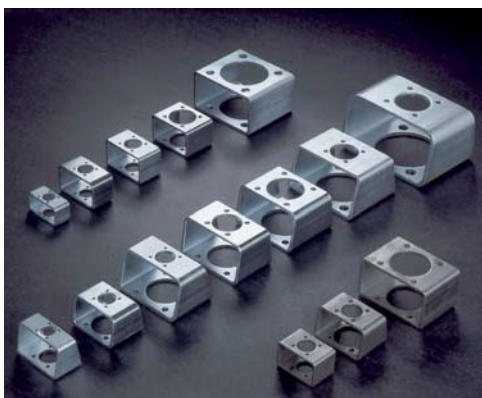

COUPLING AND BRACKETS

Air Torque has a large stock of couplings and brackets. All the accessories for valve automation available on request.

STANDARD PROTECTION LEVELS

PARTS	COATING
Body (AT045U to AT751U)	ALODUR anodized
Body (AT801U and AT1001U)	Anodized plus epoxy primer, plus polyurethane coating (RAL9007 - grey)
End-caps (AT045U to AT801U)	Anodized plus polyester coating (RAL9007 - grey - or RAL5015 blue)
End-caps (AT1001U)	Anodized plus polyester coating (RAL9007 - grey)
Carbon steel drive shaft (AT051U to AT801U)	ENP
Aluminum alloy drive shaft (AT045U and AT1001U)	ALODUR anodized

PROTECTION LEVEL A



PARTS	COATING
Body	ALODUR anodized plus PTFE coating (light grey)
End-caps	Anodized plus PTFE coating (light grey)
Carbon steel drive shaft (AT051U to AT801U)	ENP
Aluminum alloy drive shaft (AT045U and AT1001U)	ALODUR anodized

PROTECTION LEVEL D



PARTS	COATING
Body	ALODUR anodized plus epoxy coating (RAL7046 - grey)
End-caps	Anodized plus epoxy coating (RAL7046 - grey)
Stainless steel drive shaft	ENP
Stainless steel 316 fasteners	NA

PROTECTION LEVEL F



STANDARD PROTECTION LEVELS



PARTS	COATING
Body	ALODUR anodized plus PTFE coating (light grey)
End-caps	Anodized plus polyester coating (RAL9007 - grey - or RAL5015 blue)
End-caps (AT1001U)	Anodized plus polyester coating (RAL9007 - grey)
Carbon steel drive shaft (AT051U to AT801U)	ENP
Aluminum alloy drive shaft (AT045U and AT1001U)	ALODUR anodized

PROTECTION LEVEL B



PARTS	COATING
Body	ALODUR anodized plus PTFE coating (light grey)
End-caps	Anodized plus PTFE coating (light grey)
Stainless steel drive shaft	ENP

PROTECTION LEVEL E



PARTS	COATING
Body (AT045U to AT751U)	ALODUR anodized
Body (AT801U and AT1001U)	Anodized
End-caps	Anodized
Carbon steel drive shaft (AT051U to AT801U)	ENP
Aluminum alloy drive shaft (AT045U and AT1001U)	ALODUR anodized

PROTECTION LEVEL P



AVAILABLE OPTIONS AND ORDERING CODES

0	Blank: octi-cam assembled for standard travel stop adjustment K: octi-cam assembled for lock-out capability (stroke adjustment limited at +/- 5°).	7	XXD (square dimensions): single square dimension and diagonal assembling XXL: single square dimension and parallel assembling XXDS: dimension and double square S x d (a): flat head dimensions W x d: double keys dimensions
00	Blank: for standard actuator R50: 50% travel stop limitation (45° up to 90°) R100: 100% travel stop limitation (0° up to 90°) FA: fast acting FM: fail mid 180° rotation 3P: 3 position (only for spring return) 3PD: 3 position (both for spring return and double acting) HC: hydraulic damper TS: top smart connection	8	Blank: actuator with standard seals suitable for -40°C (-40°F) to 80°C (+176°F) HT: actuator construction suitable for -15°C (+5°F) to 150°C (+302°F) LLT: actuator construction suitable for -55°C (-67°F) to 80°C (+176°F)
1	Actuator model, series and rotation AT045U to AT1001U: 90° (standard) AT052U up to AT752U: 120° AT053U to AT753U: 135° AT058U to AT758U: 180°	9	Blank: standard assembly type ST, clockwise to close (spring to close) and close indication at air failure condition (or with pressurized port 4 for double acting) for in line mounting. STR: clockwise to close (spring to close) and close indication at air failure condition (or with pressurized port 4 for double acting) for across line mounting. LF: counterclockwise to close (spring to open) and open indication at air failure condition (or with pressurized port 4 for double acting) for across line mounting. LFR: counterclockwise to close (spring to open) and open indication at air failure condition (or with pressurized port 4 for double acting) for in line mounting.
2	S: spring return D: double acting		
3	Only for spring return: number of springs, spring configuration set		
4	A, B, D, E, F, P: Protection level		
5	ISO Flange		
6	Blank: no spigot Y: with spigot	10	Further requested options

(a) head flat orientation to be specified

Examples of model designation

0	00	1	2	3	4	5	6	7	8	9	10
-	-	AT201U	S	12	B	F05-F07	Y	14D	HT	-	-

AT201, Upgrade Series, spring return with 12 springs, protection level B, ISO flange F05-F07, with spigot, 14 mm diagonal single square and high temperature construction.

0	00	1	2	3	4	5	6	7	8	9	10
K	-	AT351U	D	-	A	F07-F10	-	17DS	-	LFR	-

AT351, Upgrade series, with lock-out capability, double acting, protection level A, ISO flange F07-F10, 17 mm double square and counterclockwise to close (spring to open) and open indication at air failure condition (or with pressurized port 4 for double acting) for in line mounting.

- All the Air Torque products are designed, developed and manufactured in Italy.
- Each individual actuator is factory inspected and tested.
- Each individual actuator is supplied with Certificate of Conformity.
- Each individual actuator has a serial number for full traceability.
- Each individual actuator is packed in a special cardboard carton for protection, with a product description label for easy identification and includes installation, operation and maintenance instructions in 5 languages.

AIR TORQUE PRODUCT DESIGN AND TESTING

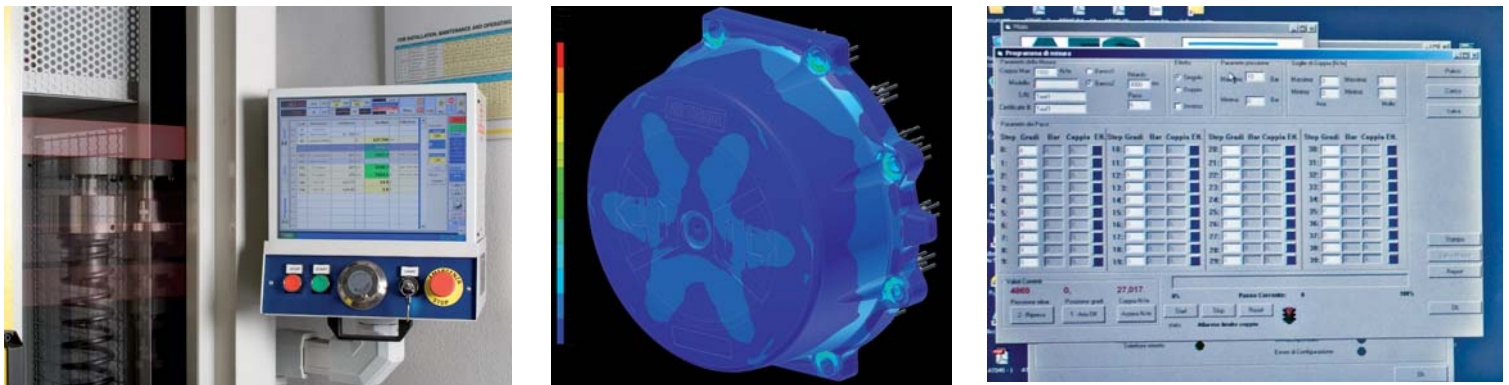

CERTIFICATIONS

ISO 9001- 2008

ATEX 94/9/EC

SIL3 IEC 61508

EN 60529 IEC 529

GOST Rostekhnadzor

GOST-R

Type Approval

INERIS

BUREAU VERITAS

REPORT 03-102

AFFILIATE DISTRIBUTORS

Air Torque GmbH

Im Katzentach 16-18
76275 Ettlingen
Germany

Phone: +49 7243 59340
Fax: +49 7243 593434
Email: info@airtorque.de

Air Torque (UK) Ltd

Unit 6 Interlink Way South
Bardon Hill Coalville
Leicestershire LE67 1PH
United of Kingdom

Phone: +44 1 530 832832
Fax +44 1 530 838986
Email: sales@airtorque.uk.com

Air Torque France

(division de STF)
7, Parc d'activités de la Verdière
13880 VELAUX
France

Phone: +33 442878400
Fax +33 442878404
Email: infos@star-line.fr

AIR TORQUE WORLDWIDE DISTRIBUTION

EUROPE

Austria
Belgium
Czech Republic
Denmark
Finland
Greece
Norway
Poland
Portugal
Russia
Slovak
Slovenia
Spain
Sweden
Switzerland
The Netherlands

ASIA PACIFIC

Australia
China
India
Japan
New Zealand
Singapore
South Korea
Taiwan
Thailand
Vietnam

NORTH AMERICA and SOUTH AMERICA

Canada
United States of America
Argentina
Brazil
Mexico

MIDDLE EAST

Israel
Turkey

AFRICA

Egypt
Morocco
South Africa

HEAD OFFICE AND WORKS

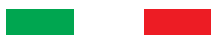

AIR TORQUE S.P.A.

Head Offices: Via dei Livelli di Sopra, 11 - Factory: Via dei Livelli di Sopra, 8
24060 COSTA DI MEZZATE (Bergamo) ITALY - Tel. +39 035 682299 - Fax +39 035 687791
www.airtorque.it - e-mail: info@airtorque.it

Your Representative:

ARA[®]
PNEUMATIK

ul. Wyscigowa 38, 53-012 Wrocław
tel. 71 364 72 82, ara@arapneumatik.pl
www.arapneumatik.pl

