

## Compax3H Installation Manual

# High power devices

Paper version



Autoryzowany dystrybutor Parker:

**ARA**  
PNEUMATIK

53-012 Wrocław tel. 71 364 72 82  
ul. Wyścigowa 38 fax 71 364 72 83  
[www.arapneumatik.pl](http://www.arapneumatik.pl)



Release R09-40

### C3Manager-Compax3H

Unterlagen / Software  
user guides / tools  
manuels / tools:

- ◆ Compax3 - DVD (english, deutsch, français)
- +
- ◆ StartUp Guide (english / deutsch)
- ◆ Compax3H Installations-Handbuch deutsch
- ◆ Compax3H Installation Manual english
- ◆ Manuel technique Compax3H français

---

Windows NT®, Windows 2000™, Windows XP™, Windows Vista, Windows 7 are trademarks of Microsoft Corporation.

## nonwarranty clause

We checked the contents of this publication for compliance with the associated hard and software. We can, however, not exclude discrepancies and do therefore not accept any liability for the exact compliance. The information in this publication is regularly checked, necessary corrections will be part of the subsequent publications.

## Production site:



Parker Hannifin Manufacturing Germany GmbH & Co. KG  
Electromechanical Automation Europe [EME]  
Robert-Bosch-Strasse 22  
77656 Offenburg (Germany)  
Tel.: + 49 (0781) 509-0  
Fax: + 49 (0781) 509-98176  
Internet: [www.parker.com/eme](http://www.parker.com/eme) <http://www.parker.com/eme>  
E-mail: [sales.automation@parker.com](mailto:sales.automation@parker.com) <mailto:EM-Motion@parker.com>

Parker Hannifin GmbH - Registered office: Bielefeld HRB 35489  
Management board: Ellen Raahede Secher, Dr.-Ing. Gerd Scheffel, Günter Schrank, Kees Veraart - Chairman of the board: Hansgeorg Greuner

**Italy:** Parker Hannifin Manufacturing Srl • SSD SBC • Electromechanical Automation •  
Via Gounod, 1  
I-20092 Cinisello Balsamo (MI), Italy  
Tel.: +39 (0)2 361081 • Fax: +39 (0)2 36108400  
E-mail: [sales.automation@parker.com](mailto:sales.automation@parker.com) <mailto:sales.sbc@parker.com> •  
Internet: [www.parker.com/eme](http://www.parker.com/eme) <http://www.parker.com/eme>

**USA:** Parker Hannifin Corporation • Electromechanical Automation  
5500 Business Park Drive • Rohnert Park, CA 94928  
Phone #: (800) 358-9068 • FAX #: (707) 584-3715  
E-mail: [CMR\\_help@parker.com](mailto:CMR_help@parker.com) [mailto:emn\\_support@parker.com](mailto:emn_support@parker.com) • Internet:  
[www.compumotor.com](http://www.compumotor.com) <http://www.compumotor.com>

**Our product on the Internet:** <http://www.parker.com/eme/c3>

# 1. Notes on the Documents Supplied

## **Compax3 - Installation manual**

The present manual contains the installation instructions for the associated **Compax3 device series** (see on page 8).

**This installation manual does contain only the basic information; for more detailed information please refer to the Help-files of the individual Compax3 device types.**

## **C3 ServoManager**

### **Compax3 - DVD**

The enclosed self-starting\* DVD contains the "C3 ServoManager" software tool for configuring, optimizing etc. Compax3.

Please use always the latest C3 ServoManager version,

## **Parker Integrated Engineering Tool**

Furthermore, the "Parker Integrated Engineering Tool", a software tool for the project management of several Parker Motion Control products, can be found on the C3 DVD.

Several axes are managed in a common project. The Compax3 ServoManager is integrated per "Plug & Play" for each Compax3 axis. The configuration, optimization,.. take place in the same way as in an independently working C3 ServoManager.

**The "C3 ServoManager" software tool is also functioning independently from the Parker Integrated Engineering Tool!**

## **Online help system**

After the installation of the ServoManager you can copy the desired Online help system with the "C3 ServoManager Help Installer" (you can select the C3 device type as well as the desired language) to your PC. The help system can be called up directly from the ServoManager. You will find the complete description of the selected device type in these online help files.

Please note that the help files are associated with defined device and software versions.

## **Catalogs**

The catalogs supplied provide an overview of and information on the Compax3 device series.

## **Adobe Acrobat Reader®**

For reading PDF files you need the "Adobe Acrobat Reader", a software tool which is available free of charge. It is distributed and generally accepted throughout the world. You can also download it directly from the Adobe website.

\* If your PC has not been set up accordingly, start the "start.htm" file on the CD.

## 1.1 C3 ServoManager

### Installation of the C3 ServoManager

The Compax3 ServoManager can be installed directly from the Compax3 DVD. Click on the corresponding hyperlink resp. start the installation program "C3Mgr\_Setup\_V.....exe" and follow the instructions.

### PC requirements

#### Recommendation:

Operating system:	MS Windows XP SP3 / MS Vista (32 Bit) / Windows 7 (32 Bit / 64 Bit)
Browser:	MS Internet Explorer 8.x or higher
Processor:	Intel / AMD Multi core processor >=2GHz
RAM memory:	>= 1024MB
Hard disk:	>= 20GB available memory
Drive:	DVD drive (for installation)
Monitor:	Resolution 1024x768 or higher
Graphics card:	on onboard graphics (for performance reasons)
Interface:	USB 2.0

#### Minimum requirements:

Operating system:	MS Windows XP SP2 / MS Windows 2000 as from SP4
Browser:	MS Internet Explorer 6.x
Processor:	>=1.5GHz
RAM memory:	512MB
Hard disk:	10GB available memory
Drive:	DVD drive
Monitor:	Resolution 1024x768 or higher
Graphics card:	on onboard graphics (for performance reasons)
Interface:	USB

#### Note:

- ◆ For the installation of the software you need administrator authorization on the target computer.
- ◆ Several applications running in parallel, reduce the performance and operability.
- ◆ Especially customer applications, exchanging standard system components (drivers) in order to improve their own performance, may have a strong influence on the communication performance or even render normal use impossible.
- ◆ Operation under virtual machines such as Vware Workstation 6/ MS Virtual PC is not possible.
- ◆ Onboard graphics card solutions reduce the system performance by up to 20% and cannot be recommended.
- ◆ Operation with notebooks in current-saving mode may lead, in individual cases, to communication problems.

### Connection between PC and Compax3

Your PC is connected with Compax3 via a RS232 cable (SSK1) and an adapter cable.

Connect SSK1 cable to the adapter cable (COM 1/2 interface at the PC to programming port - telephone socket under the upper cover).\*

Start the Compax3 ServoManager and make the setting for the selected interface in the "**Options Communication settings RS232/RS485...**" menu.

\* please make sure that a suitable strain relief is used at the telephone socket of the programming port if a SSK1 >2m is utilized.

**Device Selection** In the menu tree under device selection you can read the device type of the connected device (Online Device Identification) or select a device type (Device Selection Wizard).

**Configuration** Then you can double click on "Configuration" to start the configuration wizard. The wizard will lead you through all input windows of the configuration.

# Contents

<b>1. Notes on the Documents Supplied .....</b>	<b>3</b>
1.1 C3 ServoManager.....	4
<b>2. Introduction .....</b>	<b>8</b>
2.1 Device assignment .....	8
2.2 Scope of delivery .....	8
2.3 Type specification plate .....	9
2.4 Packaging, transport, storage .....	10
2.5 Safety instructions.....	12
2.5.1. General hazards.....	12
2.5.2. Safety-conscious working .....	12
2.5.3. Special safety instructions .....	13
2.6 Warranty conditions .....	14
2.7 Conditions of utilization .....	15
2.7.1. Conditions of utilization for CE-conform operation.....	15
2.7.2. Conditions of utilization for UL certification Compax3H.....	17
2.7.3. Current on the mains PE (leakage current).....	18
2.7.4. Supply networks .....	19
2.8 EC declaration of conformity Compax3H .....	20
<b>3. Compax3 device description .....</b>	<b>21</b>
3.1 State of delivery .....	21
3.2 Meaning of the status LEDs - Compax3 axis controller .....	21
3.3 Mounting and dimensions C3H .....	22
3.3.1. Mounting distances, air currents Compax3H050V4.....	23
3.3.2. Mounting distances, air currents Compax3H090V4.....	23
3.3.3. Mounting distances, air currents Compax3H1xxV4.....	24
3.4 Connections of Compax3H .....	25
3.4.1. Compax3H plugs/connections .....	25
3.4.2. Connection of the power voltage .....	26
3.4.3. Compax3H connections front plate .....	28
3.4.4. Plug and pin assignment C3H.....	28
3.4.5. Motor / Motor brake C3H .....	30
3.4.6. Control voltage 24 VDC C3H.....	31
3.4.7. Mains connection Compax3H.....	31
3.4.8. Braking resistor / supply voltage C3H.....	32

<b>3.5</b>	<b>Signal interfaces .....</b>	<b>33</b>
3.5.1.	RS232/RS485 interface (plug X10) .....	33
3.5.2.	Resolver / feedback (plug X13) .....	35
3.5.3.	Analogue / encoder (plug X11) .....	36
3.5.4.	Digital inputs/outputs (plug X12) .....	37
<b>4.</b>	<b>Technical Characteristics .....</b>	<b>38</b>
<b>5.</b>	<b>Index.....</b>	<b>44</b>

## 2. Introduction

### In this chapter you can read about:

Device assignment .....	8
Scope of delivery .....	8
Type specification plate .....	9
Packaging, transport, storage .....	10
Safety instructions .....	12
Warranty conditions .....	14
Conditions of utilization .....	15
EC declaration of conformity Compax3H .....	20

### 2.1 Device assignment

**This manual is valid for the following devices:**

- ◆ Compax3H050V4 + supplement
- ◆ Compax3H090V4 + supplement
- ◆ Compax3H125V4 + supplement
- ◆ Compax3H155V4 + supplement

### 2.2 Scope of delivery

#### **Device accessories**

- ◆ Mating plugs X2, X5, X6
- ◆ Capacity module CapBlok

#### **The following items are furnished with the device:**

- ◆ Manuals\*
  - ◆ Installation manual (German, English, French)
  - ◆ Compax3 DVD
  - ◆ Startup Guide (German / English)
- \*Comprehensiveness of documentation depends on device type
- ◆ Device accessories
  - Device accessories for Compax3H
    - ◆ Mating connector for X3 and X4
    - ◆ SSK32/20: RS232 adapter cable (programming port C3HxxxV4 - SSK1 - PC)
    - ◆ VBK17/01: SubD jumper mounted



## 2.3 Type specification plate

The present device type is defined by the type specification plate (on the housing):

Compax3 - Type specification plate (example):

    	Parker Hannifin GmbH Robert-Bosch-Straße 22 77656 Offenburg Tel. +49 (0) 781/509-0 www.parker-eme.com	
	PN: C3M100D6F10I20T40M11S1	Tested: 14.06.2010
	SN: 2818200005	
	<b>Power Input:</b> 565VDC	<b>Power Output*:</b> 3AC 400V (0...500 Hz), 10A
	IP20 * see manual for further ratings (192-120148)	
	<b>Made in Germany</b>	

### Explanation:

1	Type designation The complete order designation of the device (2, 5, 6, 9, 8).
2	<b>C3:</b> Abbreviation for Compax3 <b>S025:</b> Single axis device, nominal device current in 100mA (025=2.5A) <b>M050:</b> Multi-axis device, nominal device current in 100mA (050=5A) <b>H050:</b> High power device, nominal device current in 1A (050=50A)
	<b>D6:</b> Designation nominal supply <b>V2:</b> Mains supply voltage (2=230VAC/240VAC, 4=400VAC/480VAC)
3	Unique number of the particular device
4	Nominal supply voltage Power Input: Input supply data Power Output: Output data
5	Designation of the feedback system <b>F10:</b> Resolver <b>F11:</b> SinCos© / Single- or Multiturn <b>F12:</b> Feedback module for direct drives
6	Device interface <b>I10:</b> Analog, step/direction and encoder input <b>I11 / I12:</b> Digital Inputs / Outputs and RS232 / RS485 <b>I20:</b> Profibus DP / <b>I21:</b> CANopen / <b>I22:</b> DeviceNet / <b>I30:</b> Ethernet Powerlink / <b>I31:</b> EtherCAT / <b>I32:</b> Profinet <b>C20:</b> integrated controller C3 <i>powerPLmC</i> , Linux & Web server
7	Date of factory test
8	Options <b>Mxx:</b> I/O extension, HEDA <b>Sx:</b> optional safety technology on C3M
9	Technology function <b>T10:</b> Servo drive <b>T11:</b> Positioning <b>T30:</b> Motion control programmable according to IEC61131-3 <b>T40:</b> Electronic cam
10	CE compliance
11	Certified safety technology (corresponding to the logo displayed)
12	UL certified (corresponding to the logo displayed)

## 2.4 Packaging, transport, storage

### Packaging material and transport



#### Caution!

The packaging material is inflammable, if it is disposed of improperly by burning, lethal fumes may develop.

The packaging material must be kept and reused in the case of a return shipment. Improper or faulty packaging may lead to transport damages.

Make sure to transport the drive always in a safe manner and with the aid of suitable lifting equipment (**Weight** (see on page 38, see on page 38)). Do never use the electric connections for lifting. Before the transport, a clean, level surface should be prepared to place the device on. The electric connections may not be damaged when placing the device.

### First device checkup

- ◆ Check the device for signs of transport damages.
- ◆ Please verify, if the indications on the **Type identification plate** (see on page 9) correspond to your requirements.
- ◆ Check if the consignment is complete.

### Disposal

This product contains materials that fall under the special disposal regulation from 1996, which corresponds to the EC directory 91/689/EEC for dangerous disposal material. We recommend to dispose of the respective materials in accordance with the respectively valid environmental laws. The following table states the materials suitable for recycling and the materials which have to be disposed of separately.

Material Option	suitable for recycling	Disposal
Metal	yes	no
Plastic materials	yes	no
Circuit boards	no	yes

Please dispose of the circuit boards according to one of the following methods:

- ◆ Burning at high temperatures (at least 1200°C) in an incineration plant licensed in accordance with part A or B of the environmental protection act.
- ◆ Disposal via a technical waste dump which is allowed to take on electrolytic aluminum condensers. Do under no circumstances dump the circuit boards at a place near a normal waste dump.

### Storage

If you do not wish to mount and install the device immediately, make sure to store it in a dry and clean environment. Make sure that the device is not stored near strong heat sources and that no metal shavings can get into the device.

Please note in the event  
of storage >1 year:

### Forming the capacitors

**Forming the capacitors only required with 400VAC axis controllers and PSUP  
mains module**

If the device was stored longer than one year, the intermediate capacitors must be re-formed!

#### Forming sequence:

- ◆ Remove all electric connections
- ◆ Supply the device with 230VAC single phase for 30 minutes
  - ◆ via the L1 and L2 terminals on the device or
  - ◆ multi axis devices via L1 and L2 on the PSUP mains module

## 2.5 Safety instructions

### In this chapter you can read about:

General hazards .....	12
Safety-conscious working .....	12
Special safety instructions .....	13

### 2.5.1. General hazards

#### General Hazards on Non-Compliance with the Safety Instructions

The device described in this manual is designed in accordance with the latest technology and is safe in operation. Nevertheless, the device can entail certain hazards if used improperly or for purposes other than those explicitly intended.

Electronic, moving and rotating components can

- ◆ constitute a hazard for body and life of the user, and
- ◆ cause material damage

#### Designated use

The device is designed for operation in electric power drive systems (VDE0160). Motion sequences can be automated with this device. Several motion sequences can be combined by interconnecting several of these devices. Mutual interlocking functions must be incorporated for this purpose.

### 2.5.2. Safety-conscious working

This device may be operated only by qualified personnel.

Qualified personnel in the sense of these operating instructions consists of:

- ◆ Persons who, by virtue to their training, experience and instruction, and their knowledge of pertinent norms, specifications, accident prevention regulations and operational relationships, have been authorized by the officer responsible for the safety of the system to perform the required task and in the process are capable of recognizing potential hazards and avoiding them (definition of technical personnel according to VDE105 or IEC364),
- ◆ Persons who have a knowledge of first-aid techniques and the local emergency rescue services.
- ◆ persons who have read and will observe the safety instructions.
- ◆ Those who have read and observe the manual or help (or the sections pertinent to the work to be carried out).

This applies to all work relating to setting up, commissioning, configuring, programming, modifying the conditions of utilization and operating modes, and to maintenance work.

This manual and the help information must be available close to the device during the performance of all tasks.

### 2.5.3. Special safety instructions

- ◆ Check the correct association of the device and its documentation.
- ◆ Never detach electrical connections while voltage is applied to them.
- ◆ Safety devices must be provided to prevent human contact with moving or rotating parts.
- ◆ Make sure that the device is operated only when it is in perfect condition.
- ◆ Implement and activate the stipulated safety functions and devices.
- ◆ Operate the device only with the housing closed.
- ◆ Make sure that all devices are sufficiently fixed.
- ◆ Check that all live terminals are secured against contact. Perilous voltage levels of up to 850V occur.
- ◆ Do not bypass power direct current



#### Caution!

Due to movable machine parts and high voltages, the device can pose a lethal danger. Danger of electric shock in the case of non-respect of the following instructions. The device corresponds to DIN EN 61800-3, i.e. it is subject to limited sale. The device can emit disturbances in certain local environments. In this case, the user is liable to take suitable measures.

- ◆ The device must be permanently grounded due to high earth leakage currents.
- ◆ The drive motor must be grounded with a suitable protective lead.
- ◆ The devices are equipped with high voltage DC condensers. Before removing the protective cover, the discharging time must be awaited. After switching off the supply voltage, it may take up to 10 minutes to discharge the capacitors. Danger of electric shock in case of non respect.
- ◆ Before you can work on the device, the supply voltage must be switched off at the L1, L2 and L3 clamps. Wait at least 10 minutes so that the power direct current may sink to a secure value (<50V). Check with the aid of a voltmeter, if the voltage at the DC+ and DC- clamps has fallen to a value below 50V. Danger of electric shock in case of non respect.
- ◆ Do never perform resistance tests with elevated voltages (over 690V) on the wiring without separating the circuit to be tested from the drive.
- ◆ Please exchange devices only in currentless state and, in an axis system, only in a defined original state.
- ◆ In the event of a axis controller device exchange it is absolutely necessary to transfer the configuration determining the correct operation of the drive to the device, before the device is put into operation. Depending on the operation mode, a machine zero run will be necessary.
- ◆ The device contains electrostatically sensitive components. Please heed the electrostatic protection measures while working at/with the device as well as during installation and maintenance.
- ◆ Operation of the PSUP30 only with mains filter.



#### Attention - hot surface!

The heat dissipater can reach very high temperatures (>70°C)

#### Protective seals



#### Caution!

The user is responsible for protective covers and/or additional safety measures in order to prevent damages to persons and electric accidents.

Please note in the event of storage >1 year:

### Forming the capacitors

**Forming the capacitors only required with 400VAC axis controllers and PSUP mains module**

If the device was stored longer than one year, the intermediate capacitors must be re-formed!

#### Forming sequence:

- ◆ Remove all electric connections
- ◆ Supply the device with 230VAC single phase for 30 minutes
  - ◆ via the L1 and L2 terminals on the device or
  - ◆ multi axis devices via L1 and L2 on the PSUP mains module

## 2.6 Warranty conditions

- ◆ The device must not be opened.
- ◆ Do not make any modifications to the device, except for those described in the manual.
- ◆ Make connections to the inputs, outputs and interfaces only in the manner described in the manual.
- ◆ Fix the devices according to the **mounting instructions** (see on page 22). We cannot provide any guarantee for other mounting methods.

#### Note on exchange of options

Device options must be exchanged in the factory to ensure hardware and software compatibility.

- ◆ When installing the device, make sure the heat dissipators of the device receive sufficient air and respect the recommended mounting distances of the devices with integrated ventilator fans in order to ensure free circulation of the cooling air.
- ◆ Make sure that the mounting plate is not exposed to external temperature influences.

## 2.7 Conditions of utilization

**In this chapter you can read about:**

Conditions of utilization for CE-conform operation ..... 15  
 Conditions of utilization for UL certification Compax3H ..... 17  
 Current on the mains PE (leakage current) ..... 18  
 Supply networks ..... 19

### 2.7.1. Conditions of utilization for CE-conform operation

**- Industry and trade -**

The EC guidelines for electromagnetic compatibility 2004/108/EC and for electrical operating devices for utilization within certain voltage limits 2006/95/EC are fulfilled when the following boundary conditions are observed:

**Operation of devices only in the state in which they are delivered.**

In order to ensure contact protection, all mating plugs must be present on the device connections even if they are not wired.

Please respect the specifications of the manual, especially the technical characteristics (mains connection, circuit breakers, output data, ambient conditions,...).

#### 2.7.1.1 Conditions of utilization mains filter

**Mains filter:** A mains filter is required in the mains input line if the motor cable exceeds a certain length. Filtering can be provided centrally at the system mains input or separately for each device.

**Use of the devices in a commercial and residential area (limit value class in accordance with EN 61800-3)**

The following mains filters are available for independent utilization:

Device: Compax3H	Limit value class	Motor cable length	Mains filter Order No.:
H050V4	C2	< 10 m	without
	C2	> 10 m, < 50 m	NFI02/01
H090V4	C2	< 10 m	without
	C2	> 10 m, < 50 m	NFI02/02
H1xxV4	C2	< 10 m	without
	C2	> 10 m, < 50 m	NFI02/03

**Connection length: Connection between mains filter and device:**

unshielded: < 0.5 m  
 shielded < 5 (fully shielded on ground - e.g. ground of control cabinet)

#### 2.7.1.2 Conditions of utilization for cables / motor filter

**Motor and Feedback cable:**

**Operation of the devices only with motor and feedback cables whose plugs contain a special full surface area screening.**

**Compax3H motor cable** A motor output filter is required for motor cables >50m. Please contact us.

#### **Shielding connection of the motor cable**

The cable must be fully-screened and connected to the Compax3 housing. Use the cable clamps/shield connecting terminals furnished with the device.

The shield of the cable must also be connected with the motor housing. The fixing (via plug or screw in the terminal box) depends on the motor type.

**Compax3 encoder cable:** < 100 m

**Cable** Corresponding to the specifications of the terminal clamp with a temperature range of up to 75°C.

**Cable installation:**

- ◆ Signal lines and power lines should be installed as far apart as possible.
- ◆ Signal lines should never pass close to excessive sources of interference (motors, transformers, contactors etc.).
- ◆ Do not place mains filter output cable parallel to the load cable.

### **2.7.1.3 Additional conditions of utilization**

**Motors:** Operation with standard motors.

**Control:** Use only with aligned controller (to avoid control loop oscillation).

**Grounding:** Connect the filter housing and the device to the cabinet frame, making sure that the contact area is adequate and that the connection has low resistance and low inductance.

Never mount the filter housing and the device on paint-coated surfaces!

**Accessories:** Make sure to use only the accessories recommended by Parker

**Connect all cable shields at both ends, ensuring large contact areas!**

**Warning:**

**This is a product in the restricted sales distribution class according to EN 61800-3. In a domestic area this product can cause radio frequency disturbance, in which case the user may be required to implement appropriate remedial measures.**



## 2.7.2. Conditions of utilization for UL certification Compax3H

### UL certification for Compax3H

Conform to UL:	◆ according to UL508C
Certified	◆ E-File_No.: E235342

The UL certification is documented by a "UL" logo on the device (type specification plate).



### Conditions of utilization

- ◆ The devices are only to be installed in a degree of contamination 2 environment (maximum).
- ◆ The devices must be appropriately protected (e.g. by a switching cabinet).
- ◆ Tightening Torque of the Field Wiring Terminals.

### Terminal clamps - max. line cross sections

The line cross sections must correspond to the locally valid safety regulations. The local regulations have always priority.

	Power clamps (minimum/maximum section)	
<b>C3H050V4</b>	2.5 / 16mm <sup>2</sup>	
	Massive	Multewire
<b>C3H090V4</b>	16 / 50mm <sup>2</sup>	25 / 50mm <sup>2</sup>
<b>C3H1xxV4</b>	25 / 95mm <sup>2</sup>	35 / 95mm <sup>2</sup>

***The standard connection clamps of Compax3H090V4 and Compax3H1xxV4 are not suitable for flat line bars.***

***Temperature rating of field installed conductors shall be at least 75°C. Do only use copper lines.***

- ◆ Maximum Surrounding Air Temperature: 45°C.
- ◆ Short Circuit Rating - Suitable for use on a circuit capable of delivering not more than 10000 RMS symmetrical amperes and 480 volts maximum.

**CAUTION** Danger of electric shock.



Upon removing power to the equipment, wait minimum 10 minutes before accessing the drive to ensure internal voltage levels are less than 50VDC.

- ◆ The drive provides internal motor overload protection.  
This must be set so that 200% of the motor nominal current are not exceeded.
- ◆ Cable cross-sections
  - ◆ Mains input: corresponding to the recommended fuses.
  - ◆ Motor cable: corresponding to the Nominal output currents
  - ◆ This device is provided with Solid State Short Circuit (output) Protection.

### 2.7.3. Current on the mains PE (leakage current)

**Caution!**

This product can cause a direct current in the protective lead. If a residual current device (RCD) is used for protection in the event of direct or indirect contact, only a type B (all current sensitive) RCD is permitted on the current supply side of this product. Otherwise, a different protective measure must be taken, such as separation from the environment by doubled or enforced insulation or separation from the mains power supply by means of a transformer.

Please heed the connection instructions of the RCD supplier.

Mains filters do have high leakage currents due to their internal capacity. An internal mains filter is usually integrated into the servo controllers. Additional leakage currents are caused by the capacities of the motor cable and of the motor windings. Due to the high clock frequency of the power output stage, the leakage currents do have high-frequency components. Please check if the FI protection switch is suitable for the individual application.

If an external mains filter is used, an additional leakage current will be produced.

The figure of the leakage current depends on the following factors:

- ◆ Length and properties of the motor cable
- ◆ Switching frequency
- ◆ Operation with or without external mains filter
- ◆ Motor cable with or without shield network
- ◆ Motor housing grounding (how and where)

**Remark:**

- ◆ The leakage current is important with respect to the handling and usage safety of the device.
- ◆ A pulsing leakage current occurs if the supply voltage is switched on.

**Please note:**

The device must be operated with effective grounding connection, which must comply with the local regulations for high leakage currents (>3.5mA).

Due to the high leakage currents it is not advisable to operate the servo drive with an earth leakage circuit breaker.

## 2.7.4. Supply networks

This product is designed for fixed connection to TN networks (TN-C, TN-C-S or TN-S). Please note that the line-earth voltage may not exceed 300VAC.

- ◆ When grounding the neutral conductor, mains voltages of up to 480VAC are permitted.

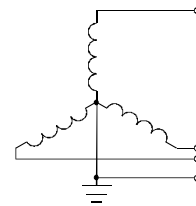

- ◆ When grounding an external conductor (delta mains, two-phase mains), mains voltages (external conductor voltages) of up to 240VAC are permitted.

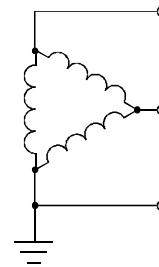

Devices which are to be connected to an IT network must be provided with a separating transformer. Then the devices are operated locally as in a TN network. The secondary sided center of the separating transformer must be grounded and connected to the PE connector of the device.

## 2.8 EC declaration of conformity Compax3H



Parker Hannifin GmbH

Robert-Bosch-Straße 22  
D-77656 Offenburg

Tel.: +49 (0) 781-509-0  
Fax.: +49 (0) 781-509-98

www.parker-eme.com

### CE KONFORMITÄTSERKLÄRUNG CE DECLARATION OF CONFORMITY

Dokumenten Nr. **DoC002-R 1.0**  
*Declaration N.*

Firma **Parker Hannifin GmbH**  
*Manufacturer*

Anschrift **Robert-Bosch-Straße 22**  
*Address* **77656 Offenburg**  
**Deutschland**

Produkt **Antrieb**  
*Product* **Drive**

Produktname **Compax3 Serie – C3H (Einachsfamilie-Hohe Leistung)**  
*Product name* **Compax3 series – C3H (Single axis family-High power)**

Die Konformität der Produkte wird vermutet, durch die Einhaltung folgender Normen:  
*The above products are in accordance with the relevant clauses from following standards:*

Norm / Standard	Titel / Title	Ausgabe / Edition
DIN EN 61800-5-1	Elektrische Leistungsantriebssysteme mit einstellbarer Drehzahl Teil 5-1: Anforderungen an die Sicherheit – Elektrische, thermische und energetische Anforderungen <i>Adjustable speed electrical power drive systems Part 5-1: Safety Requirements- Electrical, thermal and energy</i>	2008-04
DIN EN 61800-3	Drehzahlveränderbare elektrische Antriebe Teil 3: EMV-Anforderungen einschließlich spezieller Prüfverfahren <i>Adjustable speed electrical power drive systems Part 3: EMC product standard including specific test methods.</i>	2005-7

#### Bemerkungen/ Notes:

Den im Produkthandbuch beschriebenen Sicherheits-, Installations- und Bedienungshinweisen muss Folge geleistet werden.

*These products must be installed and operated with reference to the instructions in the Product Manual.  
All instructions, warnings and safety information of the Product Manual must be adhered to.*

Die Produkte entsprechen den Anforderungen der Niederspannungs-Richtlinie 2006/95/EG und der EMV-Richtlinie 2004/108/EG.

*The products are in accordance to the Low Voltage Directive 2006/95/EC and EMC Directive 2004/108/EC.*

Die Produkte sind für den Einbau in eine andere Maschine bestimmt. Die Inbetriebnahme ist solange untersagt, bis die Konformität des Endproduktes gemäß der Maschinen-Richtlinie 2006/42/EG festgestellt ist.

*The products are components to be incorporated into machinery and may not be operated alone. The complete machinery or installation may only be put into service when the safety considerations of the Machinery Directive 2006/42/EC are fully adhered to.*

Offenburg, 13/07/2009

Jürgen Killius, Operations Manager

Parker Hannifin GmbH  
Sitz: Bielefeld HRB 35489  
USt.-IdNr.: DE 122 802 922  
Steuer Nummer: 5349 5747 1543

Commerzbank Offenburg  
BLZ 664 400 84  
Konto-Nr. 45 0 19 12 00  
BIC/Swift-Code: COBADEFF  
IBAN DE95 6644 0084 0450 1912 00

**Geschäftsführung:**  
Dr. Gerd Scheffel, Günter Schrank, Christian Stein, Kees Veraart  
**Vorsitzender des Aufsichtsrates:** Hansgeorg Greuner

# 3. Compax3 device description

## In this chapter you can read about:

State of delivery .....	21
Meaning of the status LEDs - Compax3 axis controller .....	21
Mounting and dimensions C3H .....	22
Connections of Compax3H .....	25
Signal interfaces .....	33

## 3.1 State of delivery

Compax3 is delivered without configuration!

After switching on the 24VDC supply, the red LED is flashing while the green LED is dark.

Please configure the device with the help of the Windows-Software "Compax3 ServoManager"!

## 3.2 Meaning of the status LEDs - Compax3 axis controller

Device status LEDs	Right LED (red)	Left LED (green)
Voltages missing	off	off
During the booting sequence	alternately flashing	
<ul style="list-style-type: none"> <li>◆ No configuration present.</li> <li>◆ SinCos® feedback not detected.</li> <li>◆ Compax3 IEC61131-3 program not compatible with Compax3 Firmware.</li> <li>◆ no Compax3 IEC61131-3 program</li> <li>◆ For F12: Hall signals invalid.</li> </ul>	flashes slowly	off
Axis without current excitation	off	flashes slowly
Power supplied to axis; commutation calibration running	off	flashes quickly
Axis with current excitation	off	on
Axis in fault status / fault present / axis energized (error reaction 1)	flashes quickly	on
Axis in fault status / fault present / axis currentless (error reaction 2)	on	off
Compax3 faulty: please contact us	on	on

**Note on Compax3H:** The **internal** device status LEDs are only connected to the **external** housing LEDs, if the RS232 jumper at X10 is fitted to the control and the upper dummy cover is fitted.

Autoryzowany dystrybutor Parker:

# ARA

## PNEUMATIK

53-012 Wrocław tel. 71 364 72 82  
ul. Wyścigowa 38 fax 71 364 72 83

[www.arapneumatik.pl](http://www.arapneumatik.pl)



### 3.3 Mounting and dimensions C3H

The devices must be mounted vertically on a level surface in the control cabinet.

Dimensions:

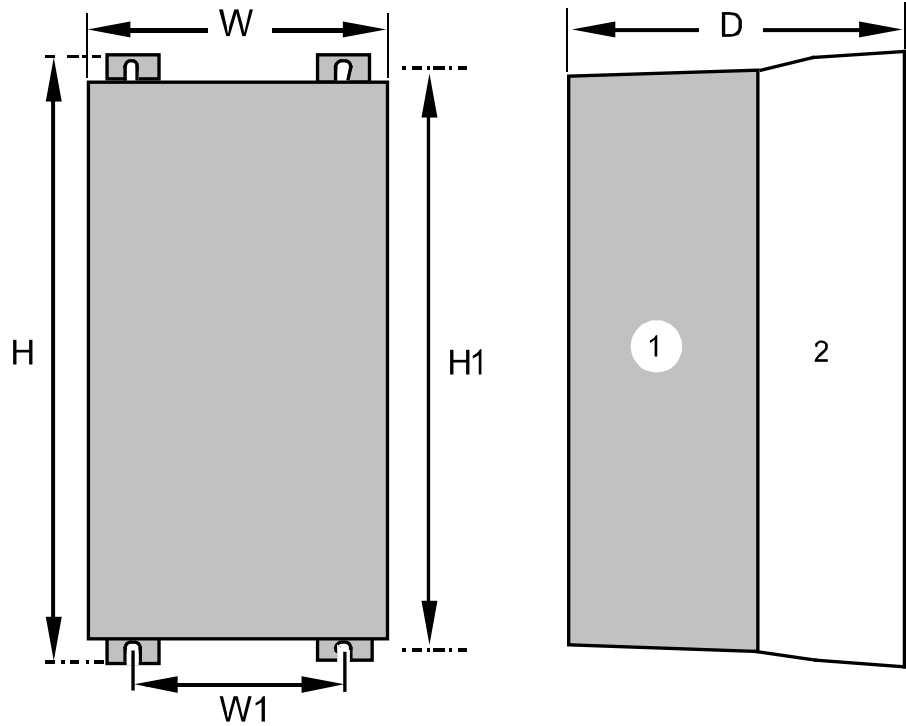

(1): Electronics  
(2): Head dissipator

	H	H1	D	W	W1
<b>C3H050V4</b>	453mm	440mm	245mm	252mm	150mm
<b>C3H090V4</b>	668.6mm	630mm	312mm	257mm	150mm
<b>C3H1xxV4</b>	720mm	700mm	355mm	257mm	150mm

**Mounting:** 4 screws M6

**Ventilation:** During operation, the device radiates heat (power loss). Please provide for a sufficient mounting distance below and above the device in order to ensure free circulation of the cooling air. Please do also respect the recommended distances of other devices. Make sure that the mounting plate is not exhibited to other temperature influences than that of the devices mounted on this very plate. If two or more devices are combined, the mounting distances are added.

### 3.3.1. Mounting distances, air currents Compax3H050V4

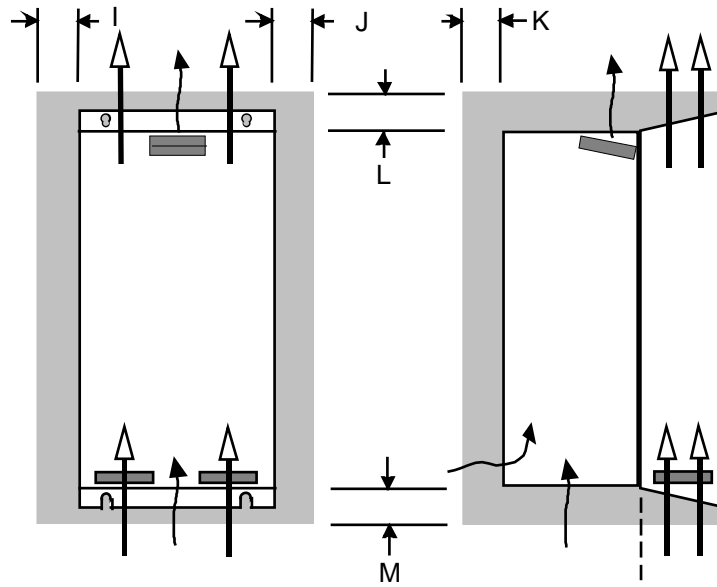

in mm

	I	J	K	L	M
<b>C3H050V4</b>	15	5	25	70	70

### 3.3.2. Mounting distances, air currents Compax3H090V4

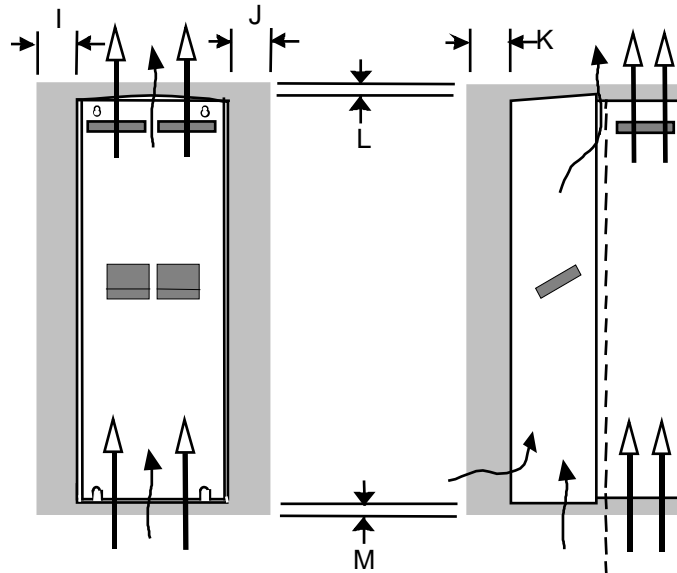

in mm

	I	J	K	L	M
<b>C3H090V4</b>	0	0	25	70	70

### 3.3.3. Mounting distances, air currents Compax3H1xxV4

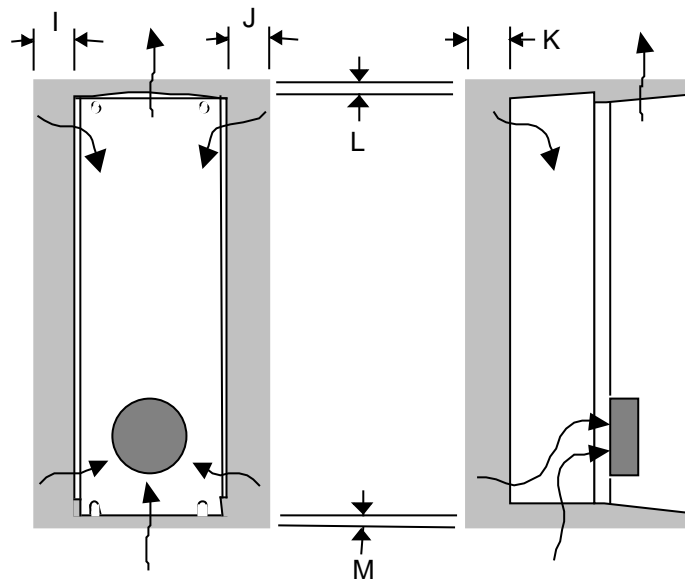

in mm

	I	J	K	L	M
<b>C3H1xxV4</b>	0	0	25	70	70



## 3.4 Connections of Compax3H

### In this chapter you can read about:

Compax3H plugs/connections .....	25
Connection of the power voltage.....	26
Compax3H connections front plate .....	28
Plug and pin assignment C3H .....	28
Motor / Motor brake C3H .....	30
Control voltage 24 VDC C3H.....	31
Mains connection Compax3H.....	31
Braking resistor / supply voltage C3H .....	32

### 3.4.1. Compax3H plugs/connections

The following figure is an example for all sizes.

The fitting of the different controller plugs depends on the extension level of Compax3.

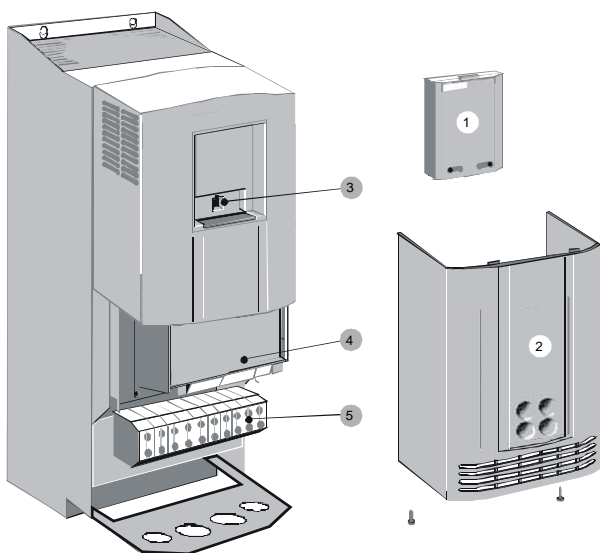

- (1): Dummy cover with display of the **external** device status LEDs.
- (2): lower clamp cover, fixed by 2 screws at the device bottom.
- (3): RS232 programming interface  
Connection to the PC via adapter cable SSK32/20 (furnished with the device) and standard RS232 cable SSK1.
- (4): Control
- (5): Power connections



**Always switch devices off before wiring them!**

**Dangerous voltages are still present until 5 minutes after switching off the power supply!**



**Caution!**

If the control voltage is missing and if the X10-X10 jumper is not fitted (VBK17/01) on the control part, the availability of power voltage is not displayed.



**PE connection**

PE connection with 10mm<sup>2</sup> via a grounding screw at the bottom of the device.



**Attention hot surface!**

Metal parts can heat up to a temperature of 90°C during operation.

### 3.4.2. Connection of the power voltage

The terminal block of the drive can be found under the front cover. It is secured with 2 screws at the bottom of the device. Remove the bottom cover in order to access the connection clamps.

Make sure that all live parts are covered by the housing after installation.

#### **Illustration of the connection clamps exemplarily for all sizes:**

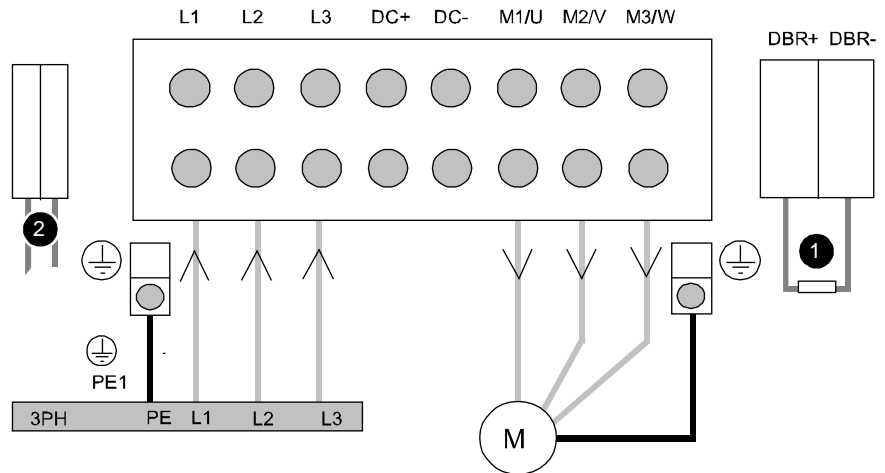

L1, L2, L3: 3 phase mains connection

M1, M2, M3: Motor connections

DC+, DC-: DC link voltage

(1) DBR+ and DBR-: Connection of external braking resistor

(2) AUX1, AUX2: only with C3H1xxV4 external supply (AC) for device ventilator L, N

- ◆ **All** shields must be connected via a cable joint to the cable feed through plate.
- ◆ Braking resistor and cable must be shielded if they are not installed in a control cabinet.
- ◆ The standard connection clamps of C3H090V4 and C3H1xxV4 are **not** suitable for flat line bars.

Attention: The MOT/TEMP connection is not supported by the Compax3H050; do therefore not wire this connection!

#### **Terminal clamps - max. line cross sections**

The line cross sections must correspond to the locally valid safety regulations. The local regulations have always priority.

	Power clamps (minimum/maximum section)	
<b>C3H050V4</b>	2.5 / 16mm <sup>2</sup>	
	Massive	Multiwire
<b>C3H090V4</b>	16 / 50mm <sup>2</sup>	25 / 50mm <sup>2</sup>
<b>C3H1xxV4</b>	25 / 95mm <sup>2</sup>	35 / 95mm <sup>2</sup>

***The standard connection clamps of Compax3H090V4 and Compax3H1xxV4 are not suitable for flat line bars.***

## Cover plate for cable feed through

The cable feed through holes have the following dimensions:	
<b>C3H050V4</b>	28.6mm for M20, PG16 and ½" NPT (America). 37.3mm for M32, PG29 and 1" NPT (America).
<b>C3H090V4</b>	22.8mm for M20, PG16 and ½" NPT (America). 28.6mm for M25, PG21 and ¾" NPT (America). 47.3mm for M40, PG36 and 1¼" NPT (America). 54.3mm for M50, PG42 and 1½" NPT (America).
<b>C3H1xxV4</b>	22.8mm for M20, PG16 and ½" NPT (America) 28.6mm for M25, PG21 and ¾" NPT (America)

## Recommended tightening torques

	High voltage supply	Ballast resistor	Grounding
<b>C3H050V4</b>	4Nm / 35lb-in	4Nm / 35lb-in	4.5Nm / 40lb-in
<b>C3H090V4</b>	6-8Nm / 53-70lb-in	6-8Nm / 53-70lb-in	6-8Nm / 53-70lb-in
<b>C3H1xxV4</b>	15-20Nm / 132-177lb-in	0.7Nm / 6.1lb-in	42Nm / 375lb-in

## Cable joints

Use metallic cable joints permitting a 360° shielding in order to comply with the EMC directive.

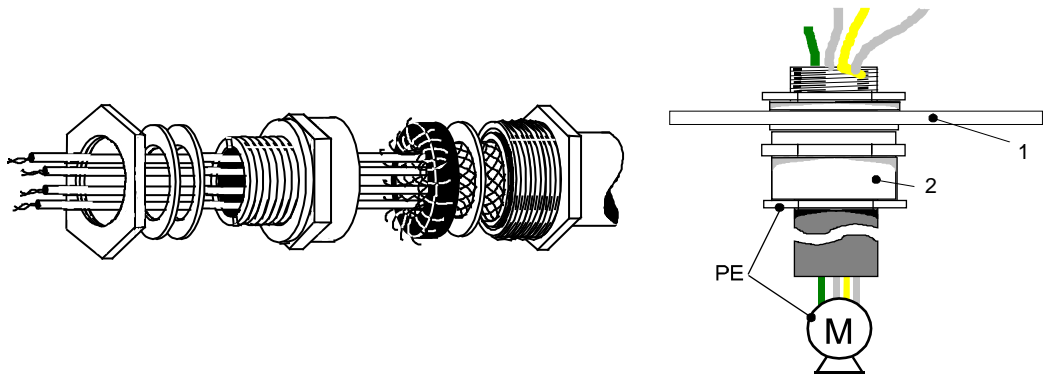

1: Cable feed through plate

2: metallic joint with 360° shielding for EMC compliant design

The device must be grounded without interruption according to EN 61800-5-1. The mains supply lines must be protected with a suitable fuse or a circuit breaker (FI switches or earth fault fuses are not recommended).

For installation in accordance with EN 61800-5-1 mm Europe:

- ◆ For grounding without interruption, two separate protective leads (<sup>2</sup> cross-section) or one lead (>10mm<sup>2</sup> cross-section) are required. Each protective lead must meet the requirements according to EN 60204.

### 3.4.3. Compax3H connections front plate

#### Communication and signal interfaces

Showcase front plate of the control (number of connectors depends on the extension level of the Compax3)

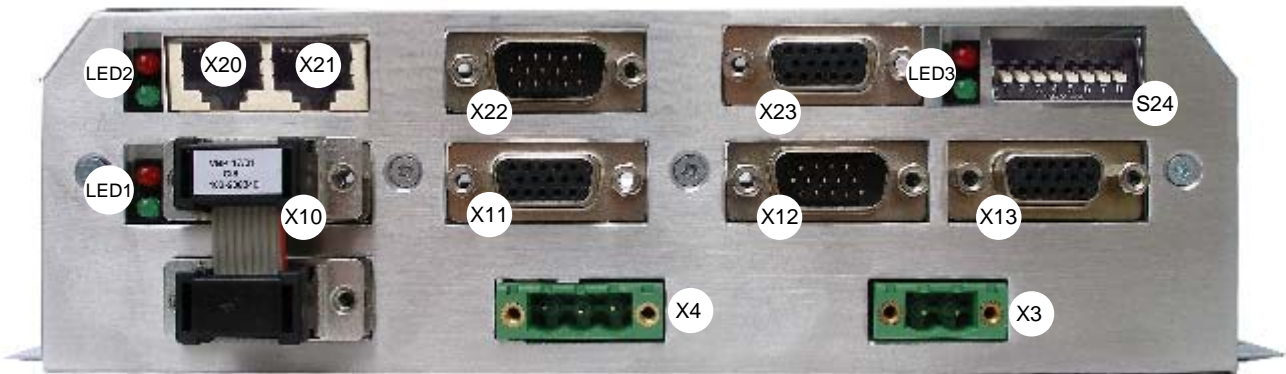

X3	Motor brake	X20	HEDA in (Option)
X4	24VDC	X21	HEDA out (Option)
X10	RS232/RS485 with jumper to the programming interface	X22	Inputs Outputs (Option M10/12)
X11	Analog/Encoder	X23	Bus (Option) Connector type depends on the bus system!
X12	Inputs/Outputs	S24	Bus settings
X13	Motor position feedback	LED1	Device status LEDs
		LED2	HEDA LEDs
		LED3	Bus LEDs

**Note on Compax3H:** The **internal** device status LEDs are only connected to the **external** housing LEDs, if the RS232 jumper at X10 is fitted to the control and the upper dummy cover is fitted.

The RS232 programming interface under the upper dummy cover is only available if the X10 jumper at the controller is fitted.

### 3.4.4. Plug and pin assignment C3H

Overview

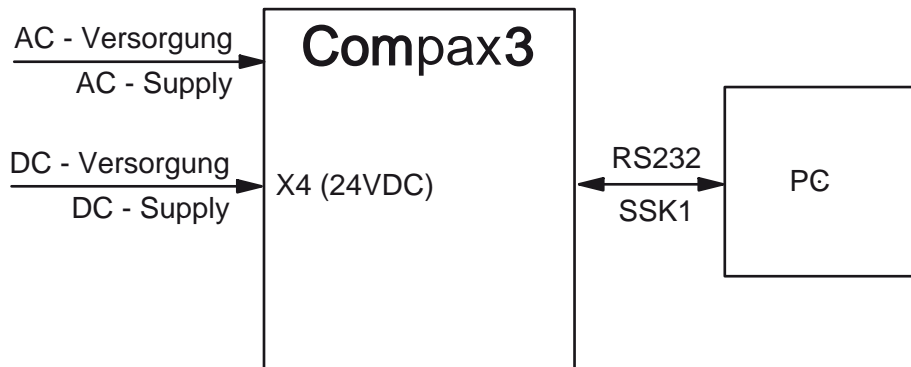

Further information on the assignment of the plug mounted at the particular device can be found below!



### 3.4.5. Motor / Motor brake C3H

**Motor connection clamps - figure (see on page 26)**

PIN	Designation	Motor cable lead designation*		
M1/U	U (motor)	U / L1 / C / L+	1	U1
M2/V	V (motor)	V / L2	2	U2
M3/W	W (motor)	W / L3 / D / L-	3	U3
PE	PE (motor)	YE / GN	YE / GN	YE / GN

\* depending on the cable type

#### Compax3H motor cable

A motor output filter is required for motor cables >50m. Please contact us.

#### Shielding connection of the motor cable

The motor cable should be fully shielded and connected to the Compax3 housing. The shield of the motor cable must also be connected with the motor housing. The fixing (via plug or screw in the terminal box) depends on the motor type.



#### Attention - Please wire the motor holding brake!

Connect the brake only on motors which have a holding brake! Otherwise make no brake connections at all.

#### Requirements cables for motor holding brake

If a motor holding brake is present, **one cable** of the motor holding brake must be fed on the device side through the toroidal core ferrite provided as accessory ZBH0x/xx (63Ω @1MHz, di=5.1mm), in order to ensure error-free switching on and off of the motor holding brake.



**Connection of motor brake X3 - figure (see on page 28)**

PIN	Designation	Motor cable lead designation*		
1	BR	WH	4	Br1
2	GND	BK	5	Br2

#### Motor holding brake output

Motor holding brake output	Compax3
Voltage range	21 – 27VDC
Maximum output current (short circuit proof)	1.6A

### 3.4.6. Control voltage 24 VDC C3H



Connection of control voltage 24VDC figure (see on page 28)

Connector X4 Pin	Description	
1	NC	NC
2	GND24V	GND
3	+24 V	24 VDC (power supply)

#### Control voltage 24VDC Compax3S and Compax3H

Controller type	Compax3
Voltage range	21 - 27VDC
Current drain of the device	0.8 A
Total current drain	0.8 A + Total load of the digital outputs + current for the motor holding brake
Ripple	0.5Vpp
Requirement according to safe extra low voltage (SELV)	yes
Short-circuit proof	conditional (internally protected with 3.15AT)

### 3.4.7. Mains connection Compax3H

Device protection

Avoid permanent switching on and off so that the charging connection is not overloaded. Therefore wait at least 1 minute before switching on the device again.

Connection of mains voltage figure (see on page 26)

#### Mains connection Compax3HxxxV4 3\*400VAC

Device type Compax3	H050V4	H090V4	H125V4	H155V4
Supply voltage	Three-phase 3*400VAC 350-528VAC / 50-60Hz			
Input current	66Arms	95Arms	143Arms	164Arms
Output current	50Arms	90Arms	125Arms	155Arms
Maximum input fuse rating per device	80A	100A	160A	200A
Recommended branch circuit protection according to UL	JDDZ Class K5 or H JDRX Class H			

#### Mains connection Compax3HxxxV4 3\*480VAC

Device type Compax3	H050V4	H090V4	H125V4	H155V4
Supply voltage	Three-phase 3*480VAC 350-528VAC / 50-60Hz			
Input current	54Arms	82Arms	118Arms	140Arms
Output current	43Arms	85Arms	110Arms	132Arms
Maximum input fuse rating per device	80A	100A	160A	200A
Recommended branch circuit protection according to UL	JDDZ Class K5 or H JDRX Class H			

### 3.4.8. Braking resistor / supply voltage C3H

The energy generated during braking operation is absorbed by the Compax3 storage capacity.

If this capacity is too small, the braking energy must be drained via a braking resistor.

#### 3.4.8.1 Connect braking resistor C3H

Connection of braking resistor - figure (see on page 26)

PIN	Designation
DBR+	+ Braking resistor
DBR-	- Braking resistor

#### Braking operation of Compax3HxxxV4

Controller type	H050V4	H090V4	H125V4	H155V4
Capacitance / storable energy 400V / 480V	2600 $\mu$ F 602 / 419 Ws	3150 $\mu$ F 729 / 507 Ws	5000 $\mu$ F 1158 / 806 Ws	5000 $\mu$ F 1158 / 806 Ws
Minimum braking- resistance	24 $\Omega$	15 $\Omega$	8 $\Omega$	8 $\Omega$
Maximum continuous current	11 A	17 A	31 A	31 A

Minimum line cross section: 2.5mm<sup>2</sup>

Maximum line length: 2m

Maximum output voltage: 830VDC

#### 3.4.8.2 Power supply voltage DC C3H

Connection of power voltage DC -figure (see on page 26)

PIN	Description
DC+	+ DC high voltage supply
DC-	- DC high voltage supply



#### **Warning!**

*Do not connect any braking resistor on DC+/DC- .*



### 3.4.8.3 Connection of the power voltage of 2 C3H 3AC devices

In order to improve the conditions during brake operation, the DC power voltage of 2 servo axes may be connected.

The capacity as well as the storable energy are increased; furthermore the braking energy of one servo axis may be utilized by a second servo axis, depending on the application.



**It is not permitted to connect the power voltage in order to use one brake circuit for two servo axes, as this function cannot be ensured reliably.**

**Note the following:**

**Caution! In case of non-compliance with the following instructions, the device may be destroyed!**

- ◆ You can only connect two similar servo axes (same power supply; same rated currents)
- ◆ Connected servo axes must always be fed separately via the AC power supply.
- ◆ If the external pre-fuse of one of the servo axes takes action, the second servo axis must also be disconnected automatically.

**Please connect as follows:**

Servo axis 1 DC+ with servo axis 2 DC+

Servo axis 1 DC- with servo axis 2 DC-

- figure (see on page 26)

## 3.5 Signal interfaces

**In this chapter you can read about:**

RS232/RS485 interface (plug X10) .....33  
 Resolver / feedback (plug X13) .....35  
 Analogue / encoder (plug X11) .....36  
 Digital inputs/outputs (plug X12) .....37

### 3.5.1. RS232/RS485 interface (plug X10)

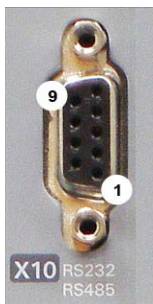

Interface selectable by contact functions assignment of X10/1:

X10/1=0V RS232

X10/1=5V RS485

PIN X10	RS232 (Sub D)
1	(Enable RS232) 0V
2	RxD
3	TxD
4	DTR
5	GND
6	DSR
7	RTS
8	CTS
9	+5V

**RS485 2-wire**

PIN X10	RS485 2-wire Sub D Pin 1 and 9 externally jumpered
1	Enable RS485 (+5V)
2	res.
3	TxD_RxD/
4	res.
5	GND
6	res.
7	TxD_RxD
8	res.
9	+5V

**RS485 4-wire**

PIN X10	RS485 4-wire Sub D Pin 1 and 9 externally jumpered
1	Enable RS485 (+5V)
2	RxD
3	TxD/
4	res.
5	GND
6	res.
7	TxD
8	RxD/
9	+5V

**USB - RS232/RS485 converter**

The following USB - RS232 converters were tested:

- ◆ ATEN UC 232A
- ◆ USB GMUS-03 (available under several company names)
- ◆ USB / RS485: **Moxa Uport 1130**  
[http://www.moxa.com/product/UPort\\_1130.htm](http://www.moxa.com/product/UPort_1130.htm)
- ◆ Ethernet/RS232/RS485: **NetCom 113** <http://www.vscom.de/666.htm>
- ◆ Exsys Adapter USB for RS232 with FTDI Processor (Windows 7)

**Note on Compax3H**

**If X10 at the control unit is used, the programming interface as well as the external device status LEDs are out of order due to the removal of the X10 jumper (VBK17/01)!**

### 3.5.2. Resolver / feedback (plug X13)

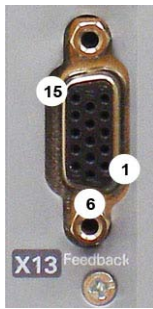

PIN X13	Feedback /X13 High Density /Sub D (depending on the Feedback module)		
	Resolver (F10)	SinCos (F11)	EnDat 2.1 (F12)
1	factory use	factory use	Sense -*
2	factory use	factory use	Sense +*
3	GND	GND	factory use
4	REF-Resolver+	Vcc (+8V)	Vcc (+5V) * max. 350mA load
5	+5V (for temperature sensor)		
6	factory use	factory use	CLKfbk
7	SIN-	SIN-	SIN- / A- (Encoder)
8	SIN+	SIN+	SIN+ / A+ (Encoder)
9	factory use	factory use	CLKfbk/
10	Tmot*	Tmot*	Tmot*
11	COS-	COS-	COS- / B- (Encoder)
12	COS+	COS+	COS+ / B+ (Encoder)
13	factory use	DATAfbk	DATAfbk
14	factory use	DATAfbk/	DATAfbk/
15	REF-Resolver-	GND (Vcc)	GND (Vcc)

\*X13 Pin10 Tmot may not be connected at the same time as X15 (on Compaxx3M).

Resolver cables can be found in the accessories chapter of the device description.

SinCos® cables can be found in the accessories chapter of the device description.

The EnDat cable GBK38 can be found in the accessories chapter of the device description.

PIN X13	Feedback /X13 High Density /Sub D
	Direct drives (F12)
1	Sense -*
2	Sense +*
3	Hall1 (digital)
4	Vcc (+5V)* max. 350 mA load
5	+5 V (for temperature sensors and Hall sensors)
6	Hall2 (digital)
7	SIN-, A- (Encoder) or analog Hall sensor
8	SIN+, A+, (Encoder) or analog Hall sensor
9	Hall3 (digital)
10	Tmot*
11	COS-, B- (Encoder) or analog Hall sensor
12	COS+, B+ (Encoder) or analog Hall sensor
13	N+
14	N-
15	GND (Vcc)

\*X13 Pin10 Tmot may not be connected at the same time as X15 (on Compaxx3M).

#### **Note on F12:**

\*+5V (Pin 4) is measured and controlled directly at the end of the line via Sense+ and Sense-.

Maximum cable length: 100m

Caution!

- ◆ Pin 4 and Pin 5 must under no circumstances be connected!
- ◆ Plug in or pull out feedback connector only in switched off state (24VDC switched off).

### 3.5.3. Analogue / encoder (plug X11)

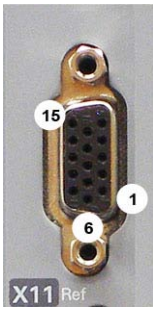

PIN X11	Reference High Density Sub D		
		Encoders	SSI
1	+24V (output) max. 70mA		
2	Ain1 -; analog input - (14Bits; max. +/-10V)		
3	D/A monitor channel 1 (±10V, 8-bit resolution)		
4	D/A monitor channel 0 (±10V, 8-bit resolution)		
5	+5 V (output for encoder) max. 150 mA		
6	- Input: steps RS422 (5V - level)	<b>A/</b> (Input / -simulation)	Clock-
7	+ Input: steps RS422 (5V - level)	<b>A/</b> (Input / -simulation)	Clock+
8	+ Input: direction RS422 (5V - level)	<b>B</b> Input / -simulation)	
9	Ain0 +: analog input + (14Bits; max. +/-10V)		
10	Ain1 +: analog input + (14Bits; max. +/-10V)		
11	Ain0 -: analog input- (14Bits; max. +/-10V)		
12	- Input: direction RS422 (5V - level)	<b>B/</b> input / -simulation)	
13	factory use	<b>N/</b> input / -simulation)	DATA-
14	factory use	<b>N</b> input / -simulation)	DATA+
15	GND		

Technical Data X11 (see on page 41)

#### 3.5.3.1 Wiring of analog interfaces

Output Input

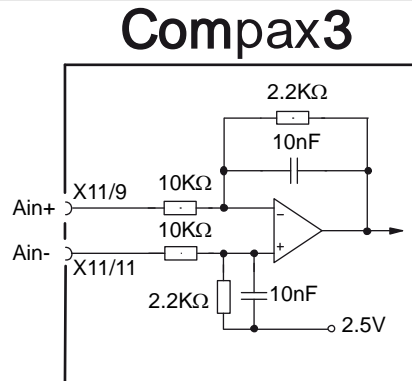
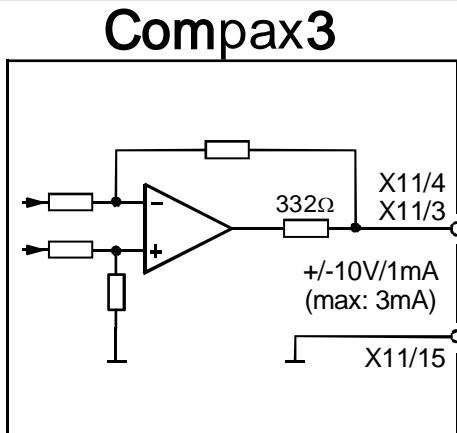

Perform an offset adjustment!

Structure image of the internal signal processing of the analog inputs  
Ain1 (X11/10 and X11/2) has the same wiring!

#### 3.5.3.2 Connections of the encoder interface

### Compax3

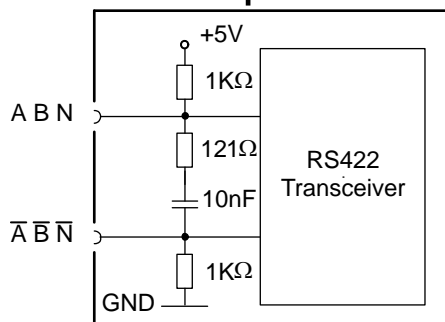

The input connection is available in triple (for A & /A, B & /B, N & /N)

### 3.5.4. Digital inputs/outputs (plug X12)

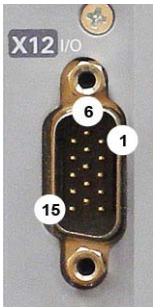

Pin X12	Input/output	I/O / X12 High density/Sub D
1	Output	+24 V DC output (max. 340mA)
2	O0	Output 0 (max. 100 mA)
3	O1	Output 1 (max. 100mA)
4	O2	Output 2 (max. 100mA)
5	O3	Output 3 (max. 100mA)
6	I0	Input 0
7	I1	Input 1
8	I2	Input 2
9	I3	Input 3
10	I4	Input 4
11	I	24V input for the digital outputs Pins 2 to 5
12	I5	Input 5
13	I6	Input 6
14	I7	Input 7
15	Output	GND24V

All inputs and outputs have 24V level.

The exact assignment depends on the the device type!

You will find the description of the device-specific assignment in the online help which can be opened from the Compax3 ServoManager.

Maximum capacitive loading of the outputs: 50nF (max. 4 Compax3 inputs).

#### 3.5.4.1 Connection of the digital Outputs/Inputs

Wiring of digital outputs

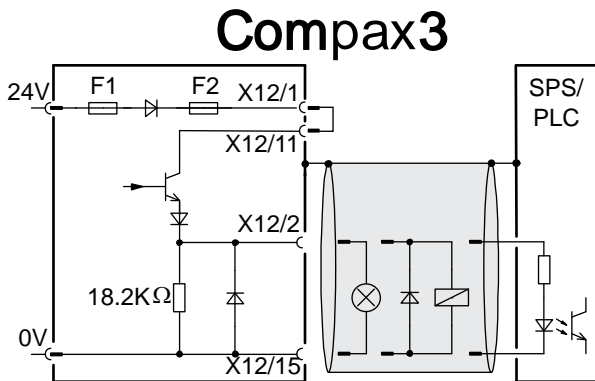

The circuit example is valid for all digital outputs!  
The outputs are short circuit proof; a short circuit generates an error.

Status of digital inputs

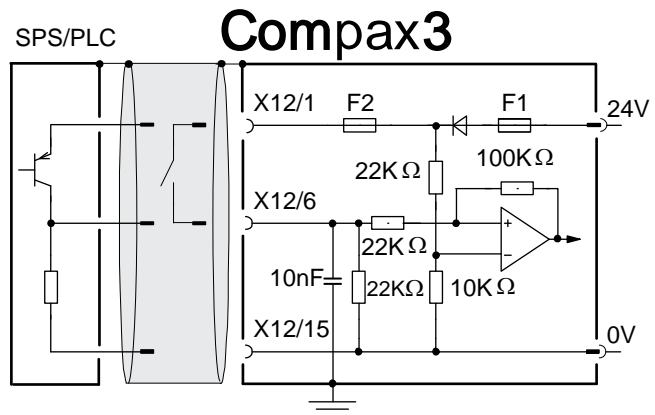

The circuit example is valid for all digital inputs!  
Signal level:  
♦ > 9.15V = "1" (38.2% of the control voltage applied)  
♦ < 8.05V = "0" (33.5% of the control voltage applied)

F1: Delayed action fuse

F2: Quick action electronic fuse; can be reset by switching the 24 VDC supply off and on again.

# 4. Technical Characteristics

## Size / weight Compax3H

Mounting (see on page 22)

Controller type	Dimensions HxWxD [mm]	Weight [kg]
Compax3H050V4	453 x 252 x 245	17.4
Compax3H090V4	668.6 x 257 x 312	32.5
Compax3H125V4	720 x 257 x 355	41
Compax3H155V4	720 x 257 x 355	41

Protection class IP20 when mounted in a control cabinet (not for Compax3H1xxxV4)

## Mains connection Compax3HxxxV4 3\*400VAC

Device type Compax3	H050V4	H090V4	H125V4	H155V4
Supply voltage	Three-phase 3*400VAC 350-528VAC / 50-60Hz			
Input current	66Arms	95Arms	143Arms	164Arms
Output current	50Arms	90Arms	125Arms	155Arms
Maximum input fuse rating per device	80A	100A	160A	200A
Recommended branch circuit protection according to UL	JDDZ Class K5 or H JDRX Class H			

## Mains connection Compax3HxxxV4 3\*480VAC

Device type Compax3	H050V4	H090V4	H125V4	H155V4
Supply voltage	Three-phase 3*480VAC 350-528VAC / 50-60Hz			
Input current	54Arms	82Arms	118Arms	140Arms
Output current	43Arms	85Arms	110Arms	132Arms
Maximum input fuse rating per device	80A	100A	160A	200A
Recommended branch circuit protection according to UL	JDDZ Class K5 or H JDRX Class H			

## Control voltage 24VDC Compax3S and Compax3H

Controller type	Compax3
Voltage range	21 - 27VDC
Current drain of the device	0.8 A
Total current drain	0.8 A + Total load of the digital outputs + current for the motor holding brake
Ripple	0.5Vpp
Requirement according to safe extra low voltage (SELV)	yes
Short-circuit proof	conditional (internally protected with 3.15AT)

**Output data Compax3Hxxx at 3\*400VAC**

Controller type	H050V4	H090V4	H125V4	H155V4
Output voltage	3x 0-400V			
Nominal output current	50Arms	90Arms	125Arms	155Arms
Pulse current for 5s *	75Arms	135Arms	187.5Arms	232.5Arms
Power	35kVA	62kVA	86kVA	107kVA
Switching frequency	8kHz	8kHz	8kHz	8kHz
Power loss for In	880W	900W	1690W	1970W

\* during low speeds, the overload time is reduced to 1s. Limit:

< 2.5 electric rev/s (= actual revolutions/s \* number of pole pairs) resp. >2.5 pitch/s

**Output data Compax3Hxxx at 3\*480VAC**

Controller type	H050V4	H090V4	H125V4	H155V4
Output voltage	3x 0-480V			
Nominal output current	43Arms	85Arms	110Arms	132Arms
Pulse current for 5s*	64.5Arms	127.5Arms	165Arms	198Arms
Power	35kVA	70kVA	91kVA	109kVA
Switching frequency	8kHz	8kHz	8kHz	8kHz
Power loss for In	850W	1103W	1520W	1800W

\* during low speeds, the overload time is reduced to 1s. Limit:

< 2.5 electric rev/s (= actual revolutions/s \* number of pole pairs) resp. >2.5 pitch/s

**Resolution of the motor position**

For option F10: Resolver	<ul style="list-style-type: none"> <li>◆ Position resolution: 16 Bits (= 0.005°)</li> <li>◆ Absolute accuracy: ±0.167°</li> </ul>
For option F11: SinCos®	<ul style="list-style-type: none"> <li>◆ Position resolution: 13.5 Bits / Encoder sine period =&gt; 0.03107°/encoder resolution</li> </ul>
For option F12:	<ul style="list-style-type: none"> <li>◆ Maximum position resolution               <ul style="list-style-type: none"> <li>◆ Linear: 24 Bits per motor magnet spacing</li> <li>◆ Rotary: 24 Bits per motor revolution</li> </ul> </li> <li>◆ For 1Vss Sine-Cosine encoders (e.g. EnDat): 13.5 bits / graduation of the scale of the encoder</li> <li>◆ For RS 422 encoders: 4x encoder resolution</li> <li>◆ Accuracy of the feedback zero pulse acquisition = accuracy of the feedback resolution.</li> <li>◆ Resolution for analog hall sensors with 1Vpp signal: 13.5 Bits / motor magnet spacing</li> </ul>

**Accuracy**

The exactitude of the position signal is above all determined by the exactitude of the feedback system used.

**Motors and feedback systems supported**

<p><b>Motors</b>  <b>Direct drives</b>                  ♦ Linear motors                  ♦ Torque motors</p>	<ul style="list-style-type: none"> <li>♦ Sinusoidally commutated synchronous motors                         <ul style="list-style-type: none"> <li>♦ Maximum electrical turning frequency: 1000Hz*</li> <li>♦ Max. Velocity on 8 pole motors: 15000min<sup>-1</sup>.</li> <li>♦ General max. speed: 60*1000/number of pole pairs in [min<sup>-1</sup>].</li> <li>♦ Max. number of poles = 600</li> </ul> </li> <li>♦ Sinusoidal commutated asynchronous motors                         <ul style="list-style-type: none"> <li>♦ Maximum electrical turning frequency: 1000Hz</li> <li>♦ Max. velocity: 60*1000/number of pole pairs - slip in [min<sup>-1</sup>].</li> <li>♦ Field weakening: typically up to triple (higher on request).</li> </ul> </li> <li>♦ Temperature sensor: KTY84-130 (insulated in accordance with EN60664-1 or IEC60664-1)</li> <li>♦ 3 phase synchronous direct drives</li> </ul>
<p><b>Position encoder (Feedback)</b></p>	<p><b><u>Option F10: Resolver</u></b></p>
<p>LTN:</p>	<p>♦ RE-21-1-A05, RE-15-1-B04</p>
<p>Tamagawa:</p>	<p>♦ TS2610N171E64, TS2620N21E11, TS2640N321E64, TS2660N31E64</p>
<p>Tyco (AMP)</p>	<p>♦ V23401-T2009-B202</p>
	<p><b><u>Option F11: SinCos®</u></b></p>
	<ul style="list-style-type: none"> <li>♦ Rotary feedback with HIPERFACE® interface:                         <ul style="list-style-type: none"> <li>♦ Singleturn (SICK Stegmann)</li> <li>♦ Multiturn (SICK Stegmann) Absolute position up to 4096 motor revolutions.</li> <li>♦ For example: SRS50, SRM50, SKS36, SKM36, SEK52, SEK52, SEL52, SEK37, SEL37, SEK160, SEK90</li> </ul> </li> </ul>

\* higher values on request



<b>Special encoder systems for direct drives</b>	<b>Option F12</b>
Analog hall sensors	<ul style="list-style-type: none"> <li>◆ Sine-Cosine signal (max. 5Vss*; typical 1Vss) 90° offset</li> <li>◆ U-V signal (max. 5Vss*; typical 1Vss) 120° offset.</li> </ul>
Encoder (linear or rotatory)	<ul style="list-style-type: none"> <li>◆ Sine-Cosine (max. 5Vss*; typical 1Vss) (max. 400kHz) or</li> <li>◆ TTL (RS422) (max. 5MHz; track A or B)</li> <li>◆ Bypass function for encoder signals (limit frequency** 5MHz, track A or B) with the following modes of commutation: <ul style="list-style-type: none"> <li>◆ Automatic commutation or</li> <li>◆ U, V, W or R, S, T commutation signals (NPN open collector) e.g. digital hall sensors, incremental encoders made by Hengstler (F series with electrical ordering variant 6)</li> </ul> </li> </ul>
Digital, bidirectional interface	<ul style="list-style-type: none"> <li>◆ All EnDat 2.1 or EnDat 2.2 (Endat01, Endat02) feedback systems with incremental track (sine-cosine track)</li> <li>◆ linear or rotary</li> <li>◆ max. 400kHz Sine-Cosine</li> </ul>
Distance coded feedback systems	<ul style="list-style-type: none"> <li>◆ Distance coding with 1VSS - Interface</li> <li>◆ Distance coding with RS422 - Interface (Encoder)</li> </ul>

\*Max. differential input between SIN- (X13/7) and SIN+ (X13/8).

\*\* Limit frequency = 1MHz for Compax3M (higher bandwidths on request)

### Motor holding brake output

<b>Motor holding brake output</b>	<b>Compax3</b>
<b>Voltage range</b>	21 – 27VDC
<b>Maximum output current (short circuit proof)</b>	1.6A

### Insulation requirements

<b>Enclosure rating</b>	Protection class in accordance with EN 60664-1
<b>Protection against human contact with dangerous voltages</b>	In accordance with EN 61800-5-1
<b>Overtoltage category</b>	Voltage category III in accordance with EN 60664-1
<b>Degree of contamination</b>	Degree of contamination 2 in accordance with EN 60664-1 and EN 61800-5-1

**Environmental conditions Compax3H**

<b>General ambient conditions</b>	In accordance with <b>EN 60 721-3-1 to 3-3</b> Climate (temperature/humidity/barometric pressure): Class 3K3	
<b>Permissible ambient temperature:</b>		
Operation storage transport	0 to +45 °C      class 3K3 -25 to +70 °C    class 2K3 -25 to +70 °C    class 2K3	
<b>Tolerated humidity:</b>	no condensation	
Operation storage transport	<= 85% class 3K3 <= 95% class 2K3 <= 95% class 2K3	(Relative humidity)
<b>Elevation of operating site</b>	<=1000m above sea level for 100% load ratings <=2000m above sea level for 1% / 100m power reduction please inquire for greater elevations	
<b>Mechanic resonances:</b>	EN 60068-2-6 (sinusoidal excitation)	
<b>Sealing</b>	Protection type IP20 in accordance with EN 60 529	

**Cooling Compax3S and Compax3H**

<b>Cooling mode:</b>	C3S025V2 ... S150V4: Convection C3S300V4 & C3H: Forced air ventilation with fan in the heat dissipator <b>Air flow rate:</b> 459m <sup>3</sup> /h (C3H)
<b>Supply:</b>	C3S300V4, C3H050, C3H090 internal C3H125, C3H155 external 220/240VAC: 140W, 2.5µF, Stator - 62Ω Optionally on request: 110/120VAC: 130W, 10µF, Stator - 16Ω <b>Circuit breaker:</b> 3A

**EMC limit values Compax3S and Compax3H**

<b>EMC interference emission</b>	Limit values in accordance with EN 61 800-3, Limit value class C3/C4 without additional mains filter: <b>Information on C2 limit value classes</b> (see on page 15)
<b>EMC disturbance immunity</b>	Industrial area limit values in accordance with EN 61 800-3

**EC directives and applied harmonized EC norms**

<b>EC low voltage directive 2006/95/EG</b>	<b>EN 61800-5-1</b> , Standard for electric power drives with settable speed; requirements to electric safety <b>EN 60664-1</b> , isolation coordinates for electrical equipment in low-voltage systems <b>EN 60204-1</b> , <b>machinery norm</b> partly applied
<b>EC-EMC-directive 2004/108/EC</b>	<b>EN 61800-3</b> , <b>EMC standard</b> Product standard for variable speed drives

**Detailed information on the technical data of the Compax3 devices can be found in the Help- or PDF-files of the individual Compax3 device types.**



# 5. Index

## A

Additional conditions of utilization • 16  
Analogue / encoder (plug X11) • 36

## B

Braking resistor / supply voltage C3H • 32

## C

C3 ServoManager • 4  
Capacitors • 11  
Compax3 device description • 21  
Compax3H connections front plate • 28  
Compax3H plugs/connections • 25  
Conditions of utilization • 15  
Conditions of utilization for cables / motor filter • 15  
Conditions of utilization for CE-conform operation • 15  
Conditions of utilization for UL certification Compax3H • 17  
Conditions of utilization mains filter • 15  
Connect braking resistor C3H • 32  
Connection of the digital Outputs/Inputs • 37  
Connection of the power voltage • 26  
Connection of the power voltage of 2 C3H 3AC devices • 33  
Connections of Compax3H • 25  
Connections of the encoder interface • 36  
Control voltage 24 VDC C3H • 31  
Current on the mains PE (leakage current) • 18

## D

Device assignment • 8  
Digital inputs/outputs • 37  
Digital inputs/outputs (plug X12) • 37

## E

EC declaration of conformity Compax3H • 20

## G

General hazards • 12

## I

Introduction • 8

## L

LEDs • 21  
Level • 37

## M

Mains connection Compax3H • 31  
Meaning of the status LEDs - Compax3 axis controller • 21  
Motor / Motor brake C3H • 30

Mounting and dimensions C3H • 22  
Mounting distances, air currents  
Compax3H050V4 • 23  
Mounting distances, air currents  
Compax3H090V4 • 23  
Mounting distances, air currents  
Compax3H1xxV4 • 24

## N

Notes on the Documents Supplied • 3

## P

Packaging, transport, storage • 10  
Plug and pin assignment C3H • 28  
Plug assignment Compax3S0xx V2 • 33, 35  
Power supply voltage DC C3H • 32

## R

Resolver • 35  
Resolver / feedback (plug X13) • 35  
RS232 plug assignment • 33  
RS232/RS485 interface (plug X10) • 33  
RS485 plug assignment • 33

## S

Safety instructions • 12  
Safety-conscious working • 12  
Scope of delivery • 8  
Signal interfaces • 33  
Special safety instructions • 13  
State of delivery • 21  
Status LEDs • 21  
Storage • 11  
Supply networks • 19

## T

Technical Characteristics • 38  
Type specification plate • 9

## U

Usage in accordance with intended purpose • 12  
USB - RS232 converter • 33

## W

Warranty conditions • 14  
Wiring of analog interfaces • 36

## X

X10 • 33  
X11 • 36  
X12 • 37  
X13 • 35

Autoryzowany dystrybutor Parker:

**ARA**

**P N E U M A T I K**

53-012 Wrocław tel. 71 364 72 82  
ul. Wyścigowa 38 fax 71 364 72 83

[www.arapneumatik.pl](http://www.arapneumatik.pl)

