

Compax3M Installation Manual

Multi-axis devices



Paper version

C3Manager-Compax3M

Unterlagen / Software
user guides / tools
manuels / tools:

- ◆ Compax3 - DVD (english, deutsch, français)
- +
- ◆ Compax3M Installations-Handbuch deutsch
- ◆ Compax3M Installation Manual english
- ◆ Manuel technique Compax3M français

Autoryzowany dystrybutor Parker:

ARA
PNEUMATIK

53-012 Wrocław tel. 71 364 72 82
ul. Wyścigowa 38 fax 71 364 72 83

www.arapneumatik.pl



Release R09-20

Windows NT®, Windows 2000™, Windows XP™, Windows Vista, Windows 7 are trademarks of Microsoft Corporation.

nonwarranty clause

We checked the contents of this publication for compliance with the associated hard and software. We can, however, not exclude discrepancies and do therefore not accept any liability for the exact compliance. The information in this publication is regularly checked, necessary corrections will be part of the subsequent publications.

Production site:



Parker Hannifin GmbH
 Electromechanical Automation Europe [EME]
 Robert-Bosch-Strasse 22
 77656 Offenburg (Germany)
 Tel.: + 49 (0781) 509-0
 Fax: + 49 (0781) 509-98176
 Internet: www.parker-eme.com <http://www.parker-eme.com>
 E-mail: sales.automation@parker.com <mailto:sales.automation@parker.com>

Parker Hannifin GmbH - registered office: Bielefeld HRB 35489
 Geschäftsführung: Dr. Gerd Scheffel, Günter Schrank, Christian Stein, Kees Veraart - Aufsichtsratsvorsitzender: Hansgeorg Greuner

Headquarters:

England: Parker Hannifin PLC • Electromechanical Automation • Arena Business Centre
 Holy Rood Close • Poole, Dorset BH17 7FJ UK
 Tel.: +44 (0)1202 606300 • Fax: +44 (0)1202 606301
 E-mail: sales.automation@parker.com <mailto:sales.automation@parker.com> •
 Internet: www.parker-eme.com <http://www.parker-eme.com>

Italy: Parker Hannifin S.p.A • SSD SBC • Electromechanical Automation • Via Gounod, 1
 I-20092 Cinisello Balsamo (MI), Italy
 Tel.: +39 (0)2 66012459 • Fax: +39 (0)2 66012808
 E-mail: sales.automation@parker.com <mailto:sales.sbc@parker.com> •
 Internet: www.parker-eme.com <http://www.parker-eme.com>

USA: Parker Hannifin Corporation • Electromechanical Automation
 5500 Business Park Drive • Rohnert Park, CA 94928
 Phone #: (800) 358-9068 • FAX #: (707) 584-3715
 E-mail: CMR_help@parker.com mailto:emn_support@parker.com • Internet:
www.compumotor.com <http://www.compumotor.com>

Our product on the Internet: <http://www.parker-eme.com/c3>

1. Notes on the Documents Supplied

Compax3 - Installation manual The present manual contains the installation instructions for the associated **Compax3 device series** (see on page 8).

This installation manual does contain only the basic information; for more detailed information please refer to the Help-files of the individual Compax3 device types.

C3 ServoManager **Compax3 - DVD**
The enclosed self-starting* DVD contains the "C3 ServoManager" software tool for configuring, optimizing etc. Compax3.
Please use always the latest C3 ServoManager version,

Parker Integrated Engineering Tool Furthermore, the "Parker Integrated Engineering Tool", a software tool for the project management of several Parker Motion Control products, can be found on the C3 DVD.
Several axes are managed in a common project. The Compax3 ServoManager is integrated per "Plug & Play" for each Compax3 axis. The configuration, optimization,.. take place in the same way as in an independently working C3 ServoManager.

The "C3 ServoManager" software tool is also functioning independently from the Parker Integrated Engineering Tool!

Online help system After the installation of the ServoManager you can copy the desired Online help system with the "C3 ServoManager Help Installer" (you can select the C3 device type as well as the desired language) to your PC. The help system can be called up directly from the ServoManager. You will find the complete description of the selected device type in these online help files.
Please note that the help files are associated with defined device and software versions.

Catalogs The catalogs supplied provide an overview of and information on the Compax3 device series.

Adobe Acrobat Reader® For reading PDF files you need the "Adobe Acrobat Reader", a software tool which is available free of charge. It is distributed and generally accepted throughout the world. You can also download it directly from the Adobe website.

* If your PC has not been set up accordingly, start the "start.htm" file on the CD.

1.1 C3 ServoManager

Installation of the C3 ServoManager

The Compax3 ServoManager can be installed directly from the Compax3 DVD. Click on the corresponding hyperlink resp. start the installation program "C3Mgr_Setup_V.....exe" and follow the instructions.

PC requirements

Recommendation:

Operating system:	MS Windows XP SP3 / MS Vista (32 Bit) / Windows 7 (32 Bit / 64 Bit)
Browser:	MS Internet Explorer 8.x or higher
Processor:	Intel / AMD Multi core processor >=2GHz
RAM memory:	>= 1024MB
Hard disk:	>= 20GB available memory
Drive:	DVD drive (for installation)
Monitor:	Resolution 1024x768 or higher
Graphics card:	on onboard graphics (for performance reasons)
Interface:	USB 2.0

Minimum requirements:

Operating system:	MS Windows XP SP2 / MS Windows 2000 as from SP4
Browser:	MS Internet Explorer 6.x
Processor:	>=1.5GHz
RAM memory:	512MB
Hard disk:	10GB available memory
Drive:	DVD drive
Monitor:	Resolution 1024x768 or higher
Graphics card:	on onboard graphics (for performance reasons)
Interface:	USB

Note:

- ◆ For the installation of the software you need administrator authorization on the target computer.
- ◆ Several applications running in parallel, reduce the performance and operability.
- ◆ Especially customer applications, exchanging standard system components (drivers) in order to improve their own performance, may have a strong influence on the communication performance or even render normal use impossible.
- ◆ Operation under virtual machines such as Vware Workstation 6/ MS Virtual PC is not possible.
- ◆ Onboard graphics card solutions reduce the system performance by up to 20% and cannot be recommended.
- ◆ Operation with notebooks in current-saving mode may lead, in individual cases, to communication problems.

Connection PC-PSUP

Your PC is connected to the PSUP (mains module) connector X3 via an USB cable (SSK33/03).

Start the Compax3 servo manager and make the setting for the assigned interface in the menu "**Options: Communication settings RS232/RS485...**".

The interface is marked as "USB Serial Port (COMx)" in the windows device manager. The no. of the COM port "x" may vary. You can find it in the PC under system control, system, hardware, device manager, connections.

Device Selection In the menu tree under device selection you can read the device type of the connected device (Online Device Identification) or select a device type (Device Selection Wizard).

Configuration Then you can double click on "Configuration" to start the configuration wizard. The wizard will lead you through all input windows of the configuration.

Contents

1. Notes on the Documents Supplied	3
1.1 C3 ServoManager.....	4
2. Introduction	8
2.1 Device assignment	8
2.2 Scope of delivery	8
2.3 Type specification plate	9
2.4 Packaging, transport, storage	11
2.5 Safety instructions.....	13
2.5.1. General hazards.....	13
2.5.2. Safety-conscious working	13
2.5.3. Special safety instructions	14
2.6 Warranty conditions	15
2.7 Conditions of utilization	16
2.7.1. Conditions of utilization for CE-conform operation.....	16
2.7.2. Conditions of utilization for UL certification Compax3M	19
2.7.3. Current on the mains PE (leakage current).....	20
2.7.4. Supply networks	21
2.8 EC declaration of conformity Compax3M.....	22
2.9 EC declaration of conformity PSUP	23
3. Device description	24
3.1 Installation instructions Compax3M	24
3.2 Mounting and dimensions.....	26
3.2.1. Mounting and dimensions PSUP10/C3M050D6, C3M100D6, C3M150D6.....	26
3.2.2. Mounting and dimensions PSUP20/PSUP30/C3M300D6	27
3.2.3. With upper mounting, the housing design may be different	27
3.3 State of delivery	28
3.4 Meaning of the status LEDs - Compax3 axis controller	28
3.5 Meaning of the status LEDs - PSUP (mains module).....	28
3.6 PSUP/Compax3M Connections	29
3.6.1. Front connector	29
3.6.2. Connections on the device bottom.....	30
3.6.3. Connections of the axis combination.....	31
3.6.4. Control voltage 24VDC PSUP (mains module)	32

3.6.5.	Mains supply PSUP (mains module) X41	32
3.6.6.	Braking resistor / temperature switch PSUP (mains module)	35
3.6.7.	Motor / motor brake Compax3M (axis controller)	37
3.6.8.	Safety technology option for Compax3M (axis controller)	38
3.7	Communication interfaces	38
3.7.1.	Communication Compax3M	38
3.8	Signal interfaces	41
3.8.1.	Resolver / feedback (plug X13)	41
3.8.2.	Analogue / encoder (plug X11)	42
3.8.3.	Digital inputs/outputs (plug X12)	43
4.	Technical Characteristics	44
5.	Index.....	51

2. Introduction

In this chapter you can read about:

Device assignment	8
Scope of delivery	8
Type specification plate	9
Packaging, transport, storage	11
Safety instructions	13
Warranty conditions	15
Conditions of utilization	16
EC declaration of conformity Compax3M	22
EC declaration of conformity PSUP	23

2.1 Device assignment

This manual is valid for the following devices:

- ◆ Compax3M050D6 + supplement
- ◆ Compax3M100D6 + supplement
- ◆ Compax3M150D6 + supplement
- ◆ Compax3M300D6 + supplement

- ◆ PSUP10D6 (mains module)
- ◆ PSUP20D6 (mains module)
- ◆ PSUP30D6 (mains module)

2.2 Scope of delivery

The following items are furnished with the device:

- ◆ Manuals*
 - ◆ Installation manual (German, English, French)
 - ◆ Compax3 DVD
 - ◆ Startup Guide (German / English)
- *Comprehensiveness of documentation depends on device type
- ◆ Device accessories
 - Device accessories for Compax3M
 - ◆ Cable clamps in different sizes for large area shielding of the motor cable, the screw for the cable clamp as well as
 - ◆ the matching plug for the Compax3M connectors X14, X15, X43
 - ◆ a toroidal core ferrite for one cable of the motor holding brake
 - ◆ an interface cable (SSK28/23) for communication within the axis combination

2.3 Type specification plate

The present device type is defined by the type specification plate (on the housing):

Compax3 - Type specification plate (example):

      	Parker Hannifin GmbH Robert-Bosch-Straße 22 77656 Offenburg Tel. +49 (0) 781/509-0 www.parker-eme.com	
	PN: C3M100D6F10I20T40M11S1	Tested: 14.06.2010
	SN: 2818200005	
	Power Input: 565VDC	
	Power Output *: 3AC 400V (0...500 Hz), 10A	
	IP20	
	* see manual for further ratings (192-120148)	
	Made in Germany	

Explanation:

1	Type designation The complete order designation of the device (2, 5, 6, 9, 8).
2	C3: Abbreviation for Compax3
	S025: Single axis device, nominal device current in 100mA (025=2.5A) M050: Multi-axis device, nominal device current in 100mA (050=5A) H050: High power device, nominal device current in 1A (050=50A)
3	D6: Designation nominal supply
	V2: Mains supply voltage (2=230VAC/240VAC, 4=400VAC/480VAC)
4	Unique number of the particular device Nominal supply voltage Power Input: Input supply data Power Output: Output data
5	Designation of the feedback system F10: Resolver F11: SinCos© / Single- or Multiturn F12: Feedback module for direct drives
6	Device interface I10: Analog, step/direction and encoder input I11 / I12: Digital Inputs / Outputs and RS232 / RS485 I20: Profibus DP / I21: CANopen / I22: DeviceNet / I30: Ethernet Powerlink / I31: EtherCAT / I32: Profinet C20: integrated controller C3 powerPLmC, Linux & Web server
7	Date of factory test
8	Options Mxx: I/O extension, HEDA Sx: optional safety technology on C3M
9	Technology function T10: Servo drive T11: Positioning T30: Motion control programmable according to IEC61131-3 T40: Electronic cam
10	CE compliance
11	Certified safety technology (corresponding to the logo displayed)
12	UL certified (corresponding to the logo displayed)

Type specification
plate: PSUP
(example)

 	Parker Hannifin GmbH Robert-Bosch-Straße 22 77656 Offenburg Tel. +49 (0) 781/509-0 www.parker-eme.com	
	1 PN: PSUP20D6USBM00 2 3 4	5 SN: 2828100002 6 Tested: 21.07.2010 
	Power Input *: 7 3*400VAC (50/60 Hz), 44A Power Output *: 7 565VDC, 20kW Aux. Supply 24VDC, class 2 IP20 * see manual for further ratings (192-120147)	
	Made in Germany	

Explanation:

1	Type designation The complete order designation of the device (2 - 4).
2	PSUPx0: Mains module 3AC 230...480V, nominal power in 1kW (10=10kW) D6: Designation nominal supply
3	Configuration and parameterization interface: USB: USB connection
4	Options: Mxx: I/O extension
5	Unique number of the particular device
6	Date of factory test
7	Nominal supply voltage: Power Input: Input supply data Power Output: Output data
8	CE compliance
9	UL certified (corresponding to the logo displayed on the device)

2.4 Packaging, transport, storage

Packaging material and transport



Caution!

The packaging material is inflammable, if it is disposed of improperly by burning, lethal fumes may develop.

The packaging material must be kept and reused in the case of a return shipment. Improper or faulty packaging may lead to transport damages.

Make sure to transport the drive always in a safe manner and with the aid of suitable lifting equipment (**Weight** (see on page 44)). Do never use the electric connections for lifting. Before the transport, a clean, level surface should be prepared to place the device on. The electric connections may not be damaged when placing the device.

First device checkup

- ◆ Check the device for signs of transport damages.
- ◆ Please verify, if the indications on the **Type identification plate** (see on page 9) correspond to your requirements.
- ◆ Check if the consignment is complete.

Disposal

This product contains materials that fall under the special disposal regulation from 1996, which corresponds to the EC directory 91/689/EEC for dangerous disposal material. We recommend to dispose of the respective materials in accordance with the respectively valid environmental laws. The following table states the materials suitable for recycling and the materials which have to be disposed of separately.

Material Option	suitable for recycling	Disposal
Metal	yes	no
Plastic materials	yes	no
Circuit boards	no	yes

Please dispose of the circuit boards according to one of the following methods:

- ◆ Burning at high temperatures (at least 1200°C) in an incineration plant licensed in accordance with part A or B of the environmental protection act.
- ◆ Disposal via a technical waste dump which is allowed to take on electrolytic aluminum condensers. Do under no circumstances dump the circuit boards at a place near a normal waste dump.

Storage

If you do not wish to mount and install the device immediately, make sure to store it in a dry and clean environment. Make sure that the device is not stored near strong heat sources and that no metal shavings can get into the device.

Please note in the event of storage >1 year:

Forming the capacitors

Forming the capacitors only required with 400VAC axis controllers and PSUP mains module

If the device was stored longer than one year, the intermediate capacitors must be re-formed!

Forming sequence:

- ◆ Remove all electric connections
- ◆ Supply the device with 230VAC single phase for 30 minutes
 - ◆ via the L1 and L2 terminals on the device or
 - ◆ multi axis devices via L1 and L2 on the PSUP mains module

2.5 Safety instructions

In this chapter you can read about:

General hazards	13
Safety-conscious working	13
Special safety instructions	14

2.5.1. General hazards

General Hazards on Non-Compliance with the Safety Instructions

The device described in this manual is designed in accordance with the latest technology and is safe in operation. Nevertheless, the device can entail certain hazards if used improperly or for purposes other than those explicitly intended.

Electronic, moving and rotating components can

- ◆ constitute a hazard for body and life of the user, and
- ◆ cause material damage

Usage in accordance with intended purpose

The device is designed for operation in electric power drive systems (VDE0160). Motion sequences can be automated with this device. Several motion sequences can be combined by interconnecting several of these devices. Mutual interlocking functions must be incorporated for this purpose.

2.5.2. Safety-conscious working

This device may be operated only by qualified personnel.

Qualified personnel in the sense of these operating instructions consists of:

- ◆ Persons who, by virtue to their training, experience and instruction, and their knowledge of pertinent norms, specifications, accident prevention regulations and operational relationships, have been authorized by the officer responsible for the safety of the system to perform the required task and in the process are capable of recognizing potential hazards and avoiding them (definition of technical personnel according to VDE105 or IEC364),
- ◆ Persons who have a knowledge of first-aid techniques and the local emergency rescue services.
- ◆ persons who have read and will observe the safety instructions.
- ◆ Those who have read and observe the manual or help (or the sections pertinent to the work to be carried out).

This applies to all work relating to setting up, commissioning, configuring, programming, modifying the conditions of utilization and operating modes, and to maintenance work.

This manual and the help information must be available close to the device during the performance of all tasks.

2.5.3. Special safety instructions

- ◆ Check the correct association of the device and its documentation.
- ◆ Never detach electrical connections while voltage is applied to them.
- ◆ Safety devices must be provided to prevent human contact with moving or rotating parts.
- ◆ Make sure that the device is operated only when it is in perfect condition.
- ◆ Implement and activate the stipulated safety functions and devices.
- ◆ Operate the device only with the housing closed.
- ◆ Make sure that all devices are sufficiently fixed.
- ◆ Check that all live terminals are secured against contact. Perilous voltage levels of up to 850V occur.
- ◆ Do not bypass power direct current



Caution!

Due to movable machine parts and high voltages, the device can pose a lethal danger. Danger of electric shock in the case of non-respect of the following instructions. The device corresponds to DIN EN 61800-3, i.e. it is subject to limited sale. The device can emit disturbances in certain local environments. In this case, the user is liable to take suitable measures.

- ◆ The device must be permanently grounded due to high earth leakage currents.
- ◆ The drive motor must be grounded with a suitable protective lead.
- ◆ The devices are equipped with high voltage DC condensers. Before removing the protective cover, the discharging time must be awaited. After switching off the supply voltage, it may take up to 10 minutes to discharge the capacitors. Danger of electric shock in case of non respect.
- ◆ Before you can work on the device, the supply voltage must be switched off at the L1, L2 and L3 clamps. Wait at least 10 minutes so that the power direct current may sink to a secure value (<50V). Check with the aid of a voltmeter, if the voltage at the DC+ and DC- clamps has fallen to a value below 50V. Danger of electric shock in case of non respect.
- ◆ Do never perform resistance tests with elevated voltages (over 690V) on the wiring without separating the circuit to be tested from the drive.
- ◆ Please exchange devices only in currentless state and, in an axis system, only in a defined original state.
- ◆ In the event of a axis controller device exchange it is absolutely necessary to transfer the configuration determining the correct operation of the drive to the device, before the device is put into operation. Depending on the operation mode, a machine zero run will be necessary.
- ◆ The device contains electrostatically sensitive components. Please heed the electrostatic protection measures while working at/with the device as well as during installation and maintenance.
- ◆ Operation of the PSUP30 only with mains filter.

**Attention - hot surface!**

The heat dissipator can reach very high temperatures (>70°C)

**Protective seals****Caution!**

The user is responsible for protective covers and/or additional safety measures in order to prevent damages to persons and electric accidents.

Please note in the event of storage >1 year:

Forming the capacitors

Forming the capacitors only required with 400VAC axis controllers and PSUP mains module

If the device was stored longer than one year, the intermediate capacitors must be re-formed!

Forming sequence:

- ◆ Remove all electric connections
- ◆ Supply the device with 230VAC single phase for 30 minutes
 - ◆ via the L1 and L2 terminals on the device or
 - ◆ multi axis devices via L1 and L2 on the PSUP mains module

2.6 Warranty conditions

- ◆ The device must not be opened.
- ◆ Do not make any modifications to the device, except for those described in the manual.
- ◆ Make connections to the inputs, outputs and interfaces only in the manner described in the manual.
- ◆ Fix the devices according to the **mounting instructions** (see on page 26). We cannot provide any guarantee for other mounting methods.

Note on exchange of options

Device options must be exchanged in the factory to ensure hardware and software compatibility.

- ◆ When installing the device, make sure the heat dissipators of the device receive sufficient air and respect the recommended mounting distances of the devices with integrated ventilator fans in order to ensure free circulation of the cooling air.
- ◆ Make sure that the mounting plate is not exposed to external temperature influences.

2.7 Conditions of utilization

In this chapter you can read about:

Conditions of utilization for CE-conform operation	16
Conditions of utilization for UL certification Compax3M.....	19
Current on the mains PE (leakage current).....	20
Supply networks	21

2.7.1. Conditions of utilization for CE-conform operation

In this chapter you can read about:

Conditions of utilization mains filter	16
Conditions of utilization for cables / motor filter	17
Additional conditions of utilization.....	17

- Industry and trade -

The EC guidelines for electromagnetic compatibility 2004/108/EC and for electrical operating devices for utilization within certain voltage limits 2006/95/EC are fulfilled when the following boundary conditions are observed:

Operation of the devices only in the condition in which they were delivered, i.e. with all housing panels.

In order to ensure contact protection, all mating plugs must be present on the device connections even if they are not wired.

Please respect the specifications of the manual, especially the technical characteristics (mains connection, circuit breakers, output data, ambient conditions,...).

2.7.1.1 Conditions of utilization mains filter

Mains filter: A mains filter is required in the mains input line if the motor cable exceeds a certain length. Filtering can be provided centrally at the system mains input or separately for each axis system.

Use of the devices in a commercial and residential area (limit value class in accordance with EN 61800-3)

The following mains filters are available for independent utilization:

Use of the devices in the industrial area (limit values class C3 in accordance with EN 61800-3)

The following mains filters are available for independent utilization:

Device: PSU	Limit value class	Reference: Axis system with motor cable	Mains filter Order No.:
P10	C3	< 6 x 10 m	NFI03/01
P10	C3	< 6 x 50 m	NFI03/02
P20	C3	< 6 x 50 m	NFI03/03
P30	C3	< 6 x 50 m	NFI03/03

Connection length: Connection between mains filter and device:

unshielded: < 0.5 m

shielded < 5 (fully shielded on ground - e.g. ground of control cabinet)

2.7.1.2 Conditions of utilization for cables / motor filter

Motor and Feedback cable:

Operation of the devices only with motor and feedback cables whose plugs contain a special full surface area screening.

Compax3M motor cable

<80m per axis (the cable must not be rolled up!)

The entire length of the motor cable per axis combination may not exceed 300m.

A motor output filter is required for motor cables >20 m:

- ◆ MDR01/04 (max. 6.3 A rated motor current)
- ◆ MDR01/01 (max. 16 A rated motor current)
- ◆ MDR01/02 (max. 30 A rated motor current)

Shielding connection of the motor cable

The cable must be fully-screened and connected to the Compax3 housing. Use the cable clamps/shield connecting terminals furnished with the device.

The shield of the cable must also be connected with the motor housing. The fixing (via plug or screw in the terminal box) depends on the motor type.

Compax3M encoder cable:

< 80m

Cable

Corresponding to the specifications of the terminal clamp with a temperature range of up to 60°C.

Cable installation:

- ◆ Signal lines and power lines should be installed as far apart as possible.
- ◆ Signal lines should never pass close to excessive sources of interference (motors, transformers, contactors etc.).
- ◆ Do not place mains filter output cable parallel to the load cable.

2.7.1.3 Additional conditions of utilization

Motors: Operation with standard motors.

Control: Use only with aligned controller (to avoid control loop oscillation).

Grounding: Connect the filter housing and the device to the cabinet frame, making sure that the contact area is adequate and that the connection has low resistance and low inductance.

Never mount the filter housing and the device on paint-coated surfaces!

Accessories: Make sure to use only the accessories recommended by Parker

Connect all cable shields at both ends, ensuring large contact areas!

Warning:

This is a product in the restricted sales distribution class according to EN 61800-3. In a domestic area this product can cause radio frequency disturbance, in which case the user may be required to implement appropriate remedial measures.

Autoryzowany dystrybutor Parker:

ARA

P N E U M A T I K

53-012 Wrocław tel. 71 364 72 82
ul. Wyścigowa 38 fax 71 364 72 83

www.arapneumatik.pl



2.7.2. Conditions of utilization for UL certification Compax3M

UL-approval for PSUP/Compax3M

conform to UL:	◆ according to UL508C
Certified	◆ E-File_No.: E235342

The UL certification is documented by a "UL" logo on the device (type specification plate).



Conditions of utilization

- ◆ The devices are only to be installed in a degree of contamination 2 environment (maximum).
- ◆ The devices must be appropriately protected (e.g. by a switching cabinet).
- ◆ Tightening torque of the field wiring terminals (green Phoenix plugs)

Device	X40: Ballast resistor	X41: Mains connector	X9: 24VDC
PSUP10	0.5 Nm (4.43Lb.in)	1.2 Nm (10.62Lb.in)	1.2 Nm (10.62Lb.in)
PSUP20	0.5 Nm (4.43Lb.in)	1.7 Nm (15Lb.in)	1.2 Nm (10.62Lb.in)
PSUP30	UL approval in preparation		
Device	X43: Motor connector	X15: Temperature monitoring	
C3M050-150	0.5Nm (4.43Lb.in)	0.22Nm (1.95Lb.in)	
C3M300	1.2Nm (10.62Lb.in)	0.22Nm (1.95Lb.in)	

- ◆ Temperature rating of field installed conductors shall be at least 60°C Use copper lines only
Please use the cables described in the accessories chapter, they feature a temperature rating of at least 60°C.
- ◆ Maximum Surrounding Air Temperature: 40°C.
- ◆ Suitable for use on a circuit capable of delivering not more than 5000 rms symmetrical amperes and 480 volts maximum.



Caution!

Danger of electric shock.

Discharge time of the bus capacitor is 10 minutes.

- ◆ The drive provides internal motor overload protection.
This must be set so that 200% of the motor nominal current are not exceeded.
- ◆ Cable cross-sections
 - ◆ Mains input: corresponding to the recommended fuses.
 - ◆ Motor cable: corresponding to the **Nominal output currents** (see on page 45)
- ◆ Maximum cross-section limited by the terminals mm² / AWG

Line cross-sections of the power connections (on the device bottoms)

Compax3 device:	Cross-section: Minimum... Maximum [with conductor sleeve]
M050, M100, M150	0.25 ... 4 mm ² (AWG: 23 ... 11)
M300	0.5 ... 6 mm ² (AWG: 20 ... 10)
PSUP10	Mains supply: 0.5 ... 6 mm ² (AWG: 20 ... 10) Braking resistor: 0.25 ... 4 mm ² (AWG: 23 ... 11)
PSUP20 & PSUP30	Mains supply: 0.5 ... 16 mm ² (AWG: 20 ... 6) Braking resistor: 0.25 ... 4 mm ² (AWG: 23 ... 11)

2.7.3. Current on the mains PE (leakage current)

**Caution!**

This product can cause a direct current in the protective lead. If a residual current device (RCD) is used for protection in the event of direct or indirect contact, only a type B (all current sensitive) RCD is permitted on the current supply side of this product. Otherwise, a different protective measure must be taken, such as separation from the environment by doubled or enforced insulation or separation from the mains power supply by means of a transformer.

Please heed the connection instructions of the RCD supplier.

Mains filters do have high leakage currents due to their internal capacity. An internal mains filter is usually integrated into the servo controllers. Additional leakage currents are caused by the capacities of the motor cable and of the motor windings. Due to the high clock frequency of the power output stage, the leakage currents do have high-frequency components. Please check if the FI protection switch is suitable for the individual application.

If an external mains filter is used, an additional leakage current will be produced.

The figure of the leakage current depends on the following factors:

- ◆ Length and properties of the motor cable
- ◆ Switching frequency
- ◆ Operation with or without external mains filter
- ◆ Motor cable with or without shield network
- ◆ Motor housing grounding (how and where)

Remark:

- ◆ The leakage current is important with respect to the handling and usage safety of the device.
- ◆ A pulsing leakage current occurs if the supply voltage is switched on.

Please note:

The device must be operated with effective grounding connection, which must comply with the local regulations for high leakage currents (>3.5mA).

Due to the high leakage currents it is not advisable to operate the servo drive with an earth leakage circuit breaker.

2.7.4. Supply networks

This product is designed for fixed connection to TN networks (TN-C, TN-C-S or TN-S). Please note that the line-earth voltage may not exceed 300VAC.

- ◆ When grounding the neutral conductor, mains voltages of up to 480VAC are permitted.

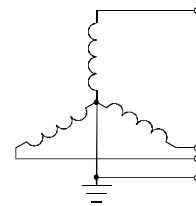

- ◆ When grounding an external conductor (delta mains, two-phase mains), mains voltages (external conductor voltages) of up to 240VAC are permitted.

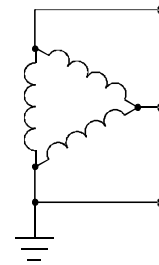

Devices which are to be connected to an IT network must be provided with a separating transformer. Then the devices are operated locally as in a TN network. The secondary sided center of the separating transformer must be grounded and connected to the PE connector of the device.

2.8 EC declaration of conformity Compax3M



Parker Hannifin GmbH

Robert-Bosch-Straße 22
D-77656 Offenburg

Tel.: +49 (0) 781-509-0
Fax.: +49 (0) 781-509-98

www.parker-eme.com

CE KONFORMITÄTSERKLÄRUNG CE DECLARATION OF CONFORMITY

Dokumenten Nr. **DoC003-R 1.0**
Declaration N.

Firma **Parker Hannifin GmbH**
Manufacturer

Anschrift **Robert-Bosch-Straße 22**
Address **77656 Offenburg**
Deutschland

Produkt **Antrieb**
Product **Drive**

Produktname **Compax3 Serie – C3M (Mehrachsfamilie)**
Product name **Compax3 series – C3M (Multi axis family)**

Die Konformität der Produkte wird vermutet, durch die Einhaltung folgender Normen:
The above products are in accordance with the relevant clauses from following standards:

Norm / Standard	Titel / Title	Ausgabe / Edition
DIN EN 61800-5-1	Elektrische Leistungsantriebssysteme mit einstellbarer Drehzahl Teil 5-1: Anforderungen an die Sicherheit – Elektrische, thermische und energetische Anforderungen <i>Adjustable speed electrical power drive systems Part 5-1: Safety Requirements- Electrical, thermal and energy</i>	2008-04
DIN EN 61800-3	Drehzahlveränderbare elektrische Antriebe Teil 3: EMV-Anforderungen einschließlich spezieller Prüfverfahren <i>Adjustable speed electrical power drive systems Part 3: EMC product standard including specific test methods.</i>	2005-7

Bemerkungen/ Notes:

Den im Produkthandbuch beschriebenen Sicherheits-, Installations- und Bedienungshinweisen muss Folge geleistet werden.

*These products must be installed and operated with reference to the instructions in the Product Manual.
All instructions, warnings and safety information of the Product Manual must be adhered to.*

Die Produkte entsprechen den Anforderungen der Niederspannungs-Richtlinie 2006/95/EG und der EMV-Richtlinie 2004/108/EG.

The products are in accordance to the Low Voltage Directive 2006/95/EC and EMC Directive 2004/108/EC.

Die Produkte sind für den Einbau in eine andere Maschine bestimmt. Die Inbetriebnahme ist solange untersagt, bis die Konformität des Endproduktes gemäß der Maschinen-Richtlinie 2006/42/EG festgestellt ist.

The products are components to be incorporated into machinery and may not be operated alone. The complete machinery or installation may only be put into service when the safety considerations of the Machinery Directive 2006/42/EC are fully adhered to.

Offenburg, 17/02/2010

Jürgen Killius, Operations Manager

Parker Hannifin GmbH
Sitz: Bielefeld HRB 35489
USt.-IdNr.: DE 122 802 922
Steuernummer: 5349 5747 1543

Commerzbank Offenburg
BLZ 664 400 84
Konto-Nr. 45 0 19 12 00
BIC/Swift-Code: COBADEFF
IBAN DE95 6644 0084 0450 1912 00

Geschäftsführung:
Dr. Gerd Scheffel, Günter Schrank, Christian Stein, Kees Veraart
Vorsitzender des Aufsichtsrates: Hansgeorg Greuner

2.9 EC declaration of conformity PSUP



Parker Hannifin GmbH

Robert-Bosch-Straße 22
D-77656 Offenburg

Tel.: +49 (0) 781-509-0
Fax.: +49 (0) 781-509-98

www.parker-eme.com

CE KONFORMITÄTSERKLÄRUNG CE DECLARATION OF CONFORMITY

Dokumenten Nr. **DoC004-R 2.0**
Declaration N.

Firma **Parker Hannifin GmbH**
Manufacturer

Anschrift **Robert-Bosch-Straße 22**
Address
77656 Offenburg
Deutschland

Produkt **Netzversorgungs-Einheit**
Product
PSU – Power Supply Unit

Produktname **Mehrachsfamilien**
Product name
Multi axis families

Die Konformität der Produkte wird vermutet, durch die Einhaltung folgender Normen:
The above products are in accordance with the relevant clauses from following standards:

Norm / Standard	Titel / Title	Ausgabe / Edition
DIN EN 61800-5-1	Elektrische Leistungsantriebssysteme mit einstellbarer Drehzahl Teil 5-1: Anforderungen an die Sicherheit – Elektrische, thermische und energetische Anforderungen <i>Adjustable speed electrical power drive systems Part 5-1: Safety Requirements- Electrical, thermal and energy</i>	2008-04
DIN EN 61800-3	Drehzahlveränderbare elektrische Antriebe Teil 3: EMV-Anforderungen einschließlich spezieller Prüfverfahren <i>Adjustable speed electrical power drive systems Part 3: EMC product standard including specific test methods.</i>	2005-7

Bemerkungen / Notes:

Den im Produkthandbuch beschriebenen Sicherheits-, Installations- und Bedienungshinweisen muss Folge geleistet werden.

*These products must be installed and operated with reference to the instructions in the Product Manual.
All instructions, warnings and safety information of the Product Manual must be adhered to.*

Die Produkte entsprechen den Anforderungen der Niederspannungs-Richtlinie 2006/95/EG und der EMV-Richtlinie 2004/108/EG.

The products are in accordance to the Low Voltage Directive 2006/95/EC and EMC Directive 2004/108/EC.

Die Produkte sind für den Einbau in eine andere Maschine bestimmt. Die Inbetriebnahme ist solange untersagt, bis die Konformität des Endproduktes gemäß der Maschinen-Richtlinie 2006/42/EG festgestellt ist.

The products are components to be incorporated into machinery and may not be operated alone. The complete machinery or installation may only be put into service when the safety considerations of the Machinery Directive 2006/42/EC are fully adhered to.

Offenburg, 14/09/2010

Jürgen Killius, Operations Manager

Parker Hannifin GmbH
Sitz: Bielefeld HRB 35489
USt.-IdNr.: DE 122 802 922
Steuernummer: 5349 5747 1543

Commerzbank Offenburg
BLZ 664 400 84
Konto-Nr. 45 0 19 12 00
BIC/Swift-Code: COBADEFF
IBAN DE95 6644 0084 0450 1912 00

Geschäftsführung:
Dr. Gerd Scheffel, Günter Schrank, Christian Stein, Kees Veraart
Vorsitzender des Aufsichtsrates: Hansgeorg Greuner

3. Device description

In this chapter you can read about:

Installation instructions Compax3M.....	24
Mounting and dimensions	26
State of delivery	28
Meaning of the status LEDs - Compax3 axis controller	28
Meaning of the status LEDs - PSUP (mains module)	28
PSUP/Compax3M Connections	29
Communication interfaces	38
Signal interfaces	41

3.1 Installation instructions Compax3M

General introductory notes

- ◆ Operation of the Compax3M multi-axis combination is only possible in connection with a PSUP (mains module).
- ◆ Axis controllers are aligned at the right of the mains module.
- ◆ Arrangement within the multi-axis combination sorted by power (with the same device types according to device utilization), the axis controller with the highest power is placed directly at the right of the mains module.
e.g. first the device type with high utilization, at the right of this, the same device type with a lower utilization.
- ◆ Max. 15 Compax3M (axis controllers) per PSUP (mains module) are permitted (please respect the total capacity of max. 2400µF for PSUP10, max. 5000µF for PSUP20).
- ◆ The continuation of the current rail connection outside the axis combination is not permitted and will lead to a loss of the CE and UL approbation.
- ◆ External components **may not** be connected to the rail system.

Required tools:

- ◆ Allen key M5 for fixing the devices in the control cabinet.
- ◆ Crosstip screwdriver M4 for connection rails of the DC rail modules.
- ◆ Crosstip screwdriver M5 for grounding screw of the device.
- ◆ Flat-bladed screwdriver 0.4x2.5 / 0.6x3.5 / 1.0x4.0 for wiring and mounting of the phoenix clamps.

Order of installation

- ◆ Fixing the devices in the control cabinet.
 - ◆ Predrilling the mounting plate in the control cabinet according to the specifications. **Dimensions** (see on page 26). Fit M5 screws loosely in the bores.
 - ◆ Fit device on the upper screws and place on lower screw. Tighten screws of all devices. The tightening torque depends on the screw type (e.g. 5.9Nm for M5 screw DIN 912 8.8).
- ◆ Connection of the internal supply voltage.

The Compax3M axis controllers are connected to the supply voltages via the rail modules. **Details** (see on page 31).

 - ◆ Deblocking the yellow protective cover with a flat-bladed screwdriver on the upper surface (click mechanism). Remove the closing devices (contact protection) that are not required from between the devices.
 - ◆ Connecting the rail modules, beginning with the mains module.

For this, loosen crosshead screws (5 screws at the right in the mains module, all 10 screws in the next axis controller), push the rails one after the other against to the left and tighten screws. Proceed accordingly for all adjacent axis controllers in the combination.

Max. tightening torque: 1.5Nm.
 - ◆ Close all protective covers. The protective covers must latch audibly.

Please note:

Insufficiently fixed screw connections of the DC power voltage rails may lead to the destruction of the devices.

Protective seals



Caution - Risk of Electric Shock!

In order to secure the contact protection against the alive rails, it is absolutely necessary to respect the following:

- ◆ Insert the yellow plastic comb at the left or right of the rails.

Make sure that the yellow plastic combs are placed at the left of the first device and at the right of the last device in the system and have not been removed.
- ◆ Setup of the devices only with closed protective covers.
- ◆ Connect protective earth to mains module (M5 crosshead screw on front of device bottom).
- ◆ Connecting the internal communication. **Details** (see on page 39).
- ◆ Connecting the signal and fieldbus connectors. **Details** (see on page 41).
- ◆ Connection of mains power supply **Details** (see on page 32) ballast resistor **details** (see on page 35) and motor **details** (see on page 37).
- ◆ Connecting the configuration interface to the PC. **Details** (see on page 38).

3.2 Mounting and dimensions

Ventilation: During operation, the device radiates heat (power loss). Please provide for a sufficient mounting distance below and above the device in order to ensure free circulation of the cooling air. Please do also respect the recommended distances of other devices. Make sure that the mounting plate is not exhibited to other temperature influences than that of the devices mounted on this very plate. The devices must be mounted vertically on a level surface. Make sure that all devices are sufficiently fixed.

3.2.1. Mounting and dimensions PSUP10/C3M050D6, C3M100D6, C3M150D6

The devices are force-ventilated via a ventilator fan fixed to the lower part of the heat dissipator!

Mounting spacing: At the top and below: at least 100mm

Information on PSUP10D6/C3M050D6, C3M100D6, C3M150D6

Mounting:
2 socket head screws M5

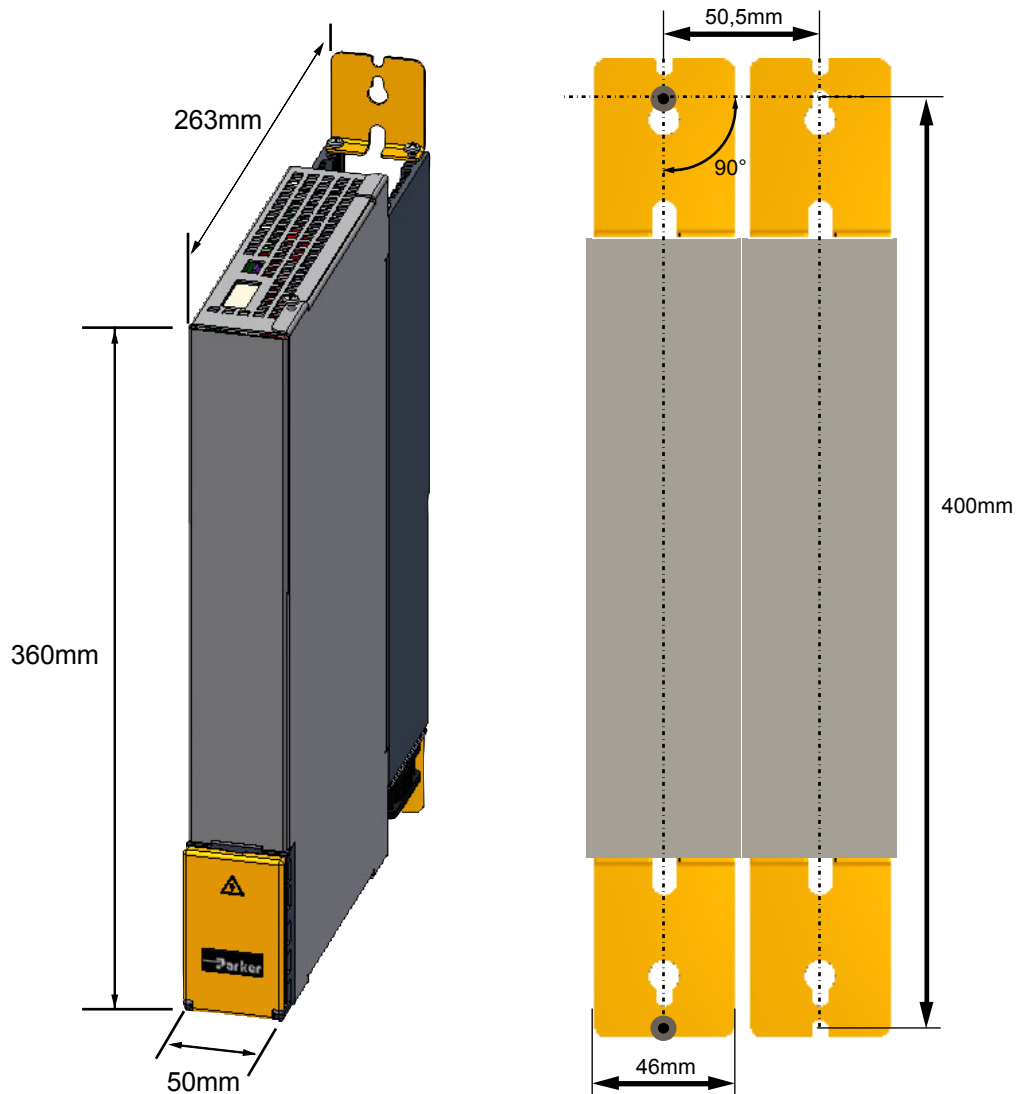

Tolerances: DIN ISO 2768-f

3.2.2. Mounting and dimensions PSUP20/PSUP30/C3M300D6

Information on PSUP20/PSUP30/C3M300D6

Mounting:

4 socket head screws M5

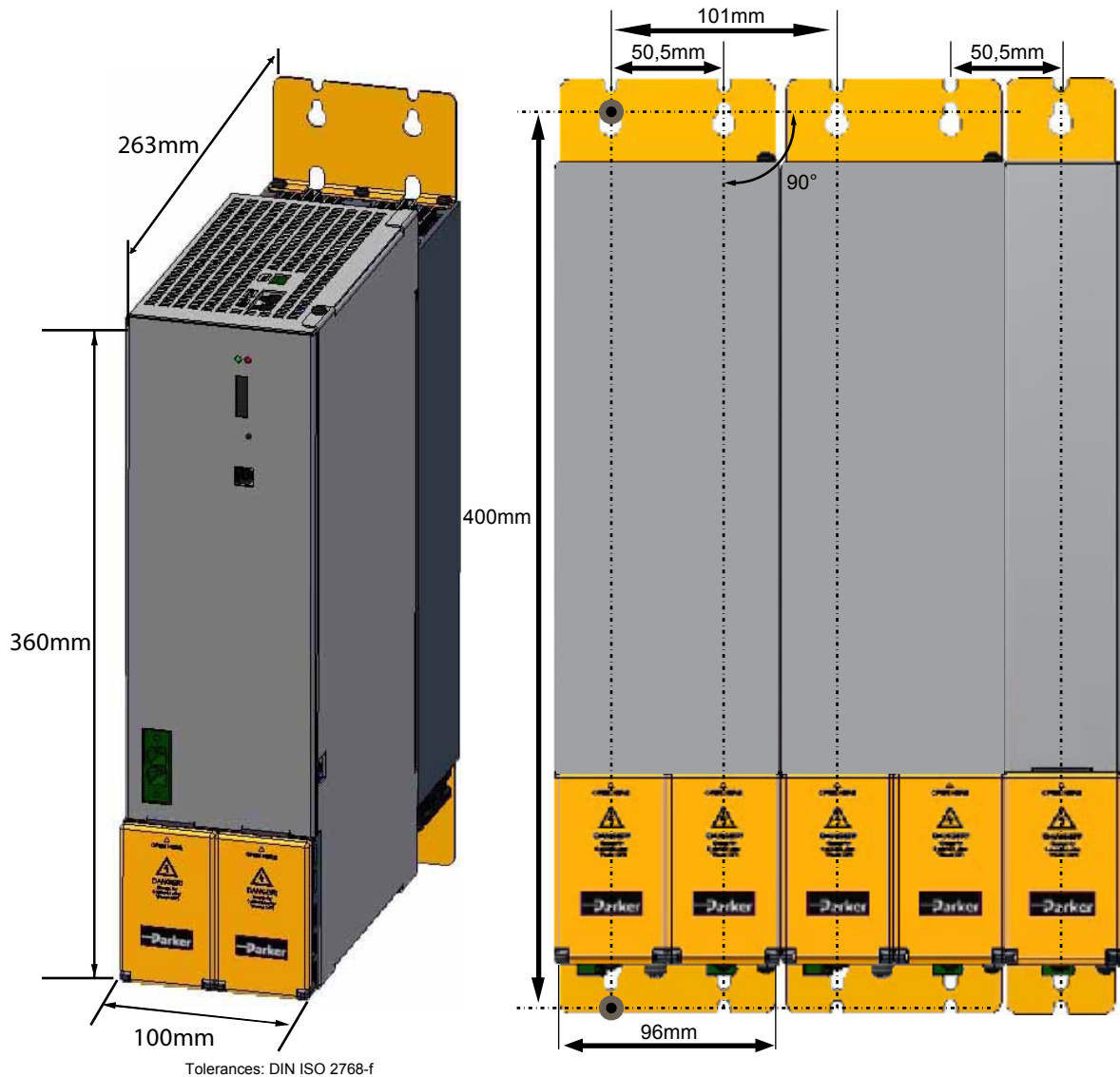

3.2.3. With upper mounting, the housing design may be different

Mounting:

3 socket head screws M5

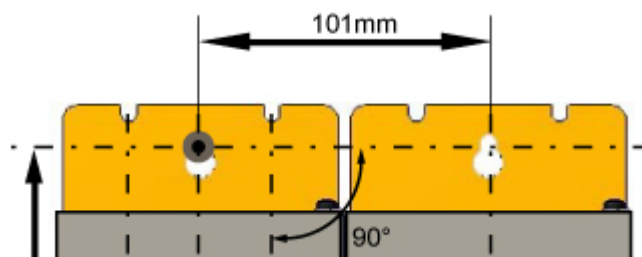

3.3 State of delivery

Compax3 is delivered without configuration!

After switching on the 24VDC supply, the red LED is flashing while the green LED is dark.

Please configure the device with the help of the Windows-Software "Compax3 ServoManager"!

3.4 Meaning of the status LEDs - Compax3 axis controller

Device status LEDs	Right LED (red)	Left LED (green)
Voltages missing	off	off
During the booting sequence	alternately flashing	
<ul style="list-style-type: none"> ◆ No configuration present. ◆ SinCos® feedback not detected. ◆ Compax3 IEC61131-3 program not compatible with Compax3 Firmware. ◆ no Compax3 IEC61131-3 program ◆ For F12: Hall signals invalid. 	flashes slowly	off
Axis without current excitation	off	flashes slowly
Power supplied to axis; commutation calibration running	off	flashes quickly
Axis with current excitation	off	on
Axis in fault status / fault present / axis energized (error reaction 1)	flashes quickly	on
Axis in fault status / fault present / axis currentless (error reaction 2)	on	off
Compax3 faulty: please contact us	on	on

3.5 Meaning of the status LEDs - PSUP (mains module)

PSUP Status LEDs	Left LED (green)	Right LED (red)
Control voltage 24 VDC is missing	off	off
Error of mains module*	off	on
DC power voltage is built up	-	flashes quickly
Phase failure / mains power supply undervoltage	on	flashes slowly
Address assignment CPU active	flashes quickly	-
Address assignment CPU completed	flashes slowly	-
PSUPxx Ready - State	on	off
Incorrect wiring of internal communication X30/31	flashes slowly	flashes quickly
Device in bootloader state	flashes slowly	flashes slowly

*can be read out in each axis controller



Caution!

When the control voltage is missing there is no indication whether or not high voltage supply is available.

3.6 PSUP/Compax3M Connections

In this chapter you can read about:

Front connector29
 Connections on the device bottom30
 Connections of the axis combination31
 Control voltage 24VDC PSUP (mains module)32
 Mains supply PSUP (mains module) X4132
 Braking resistor / temperature switch PSUP (mains module)35
 Motor / motor brake Compax3M (axis controller)37
 Safety technology option for Compax3M (axis controller).....38

3.6.1. Front connector

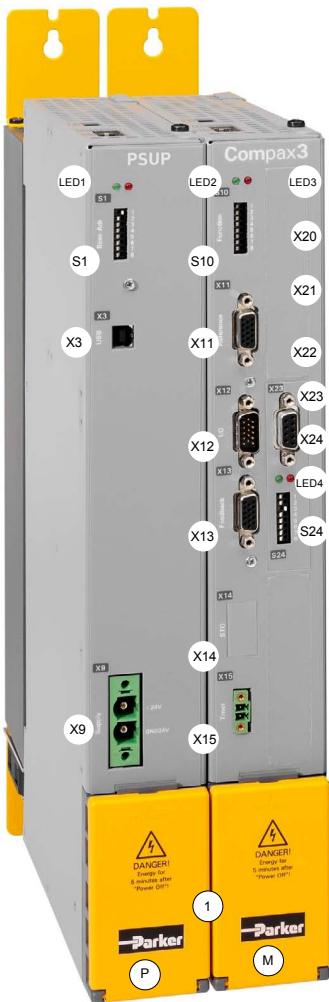

P	Mains module PSUP
LED1	Status LEDs Mains module
S1	Basic address
X3	Configuration interface (USB)
X9	Supply voltage 24VDC
M	Axis controller
LED2	Status LEDs of the axis
S10	Function
X11	Analog/Encoder
X12	Inputs/Outputs
X13	Motor position feedback
X14	Safety technology (option)
X15	Motor temperature monitoring
LED3	HEDA LEDs
X20	HEDA in (Option)
X21	HEDA out (Option)
X22	Inputs Outputs (Option M10/12)
X23	Bus (option) connector type depends on the bus system!
X24	Bus (option) depends on the bus system!
LED4	Bus LEDs
S24	bus settings
1	Behind the yellow protective covers you can find the rails for the supply voltage connection. ♦ Supply voltage 24VDC ♦ DC power voltage supply

3.6.2. Connections on the device bottom



Caution - Risk of Electric Shock!

Always switch devices off before wiring them!

Dangerous voltages are still present until 10 min. after switching off the power supply.



Caution!

When the control voltage is missing there is no indication whether or not high voltage supply is available.



Attention - PE connection!

PE connection with 10mm² via a grounding screw at the bottom of the device.



Attention - hot surface!

The heat dissipator can reach very high temperatures (>70°C)

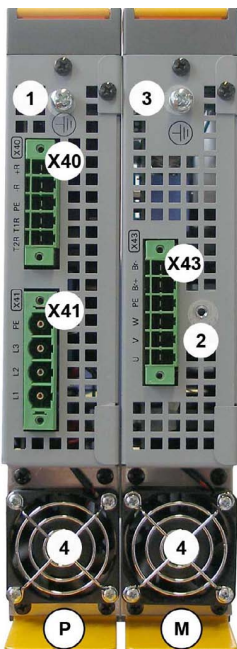

P	Mains module PSUP
X40	Ballast resistor
X41	Mains supply VAC/PE
1	Central ground connection for the axis system, with 10mm ² to the ground screw on the housing.
4	Fan*
M	Axis controller
X43	Motor / Brake
2	Fixing for motor shield clamp
4	Fan*
3	optionally, the axis controller features a ground screw on the housing, if the grounding is not possible via the back plate.

* is internally supplied.

Line cross-sections of the power connections (on the device bottoms)

Compax3 device:	Cross-section: Minimum... Maximum [with conductor sleeve]
M050, M100, M150	0.25 ... 4 mm ² (AWG: 23 ... 11)
M300	0.5 ... 6 mm ² (AWG: 20 ... 10)
PSUP10	Mains supply: 0.5 ... 6 mm ² (AWG: 20 ... 10) Braking resistor: 0.25 ... 4 mm ² (AWG: 23 ... 11)
PSUP20 & PSUP30	Mains supply: 0.5 ... 16 mm ² (AWG: 20 ... 6) Braking resistor: 0.25 ... 4 mm ² (AWG: 23 ... 11)

3.6.3. Connections of the axis combination

The axis controllers are connected to the supply voltages via rails.

- ◆ Supply voltage 24VDC
- ◆ DC power voltage supply

The rails can be found behind the yellow protective covers. In order to connect the rails of the devices, you may have to remove the yellow plastic device inserted at the side.

CAUTION: Risk of Electric Shock



Caution - Risk of Electric Shock!

Please note before opening:

- ◆ **Warning** - Possible risk of electric shock; disconnect power before removing cover.
- ◆ **Caution!** - Dangerous electric voltage! Respect discharge time.



Caution - Risk of Electric Shock!

Always switch devices off before wiring them!

Dangerous voltages are still present until 10 min. after switching off the power supply.



Caution!

When the control voltage is missing there is no indication whether or not high voltage supply is available.

Protective seals



Caution - Risk of Electric Shock!

In order to secure the contact protection against the alive rails, it is absolutely necessary to respect the following:

- ◆ Insert the yellow plastic comb at the left or right of the rails.
Make sure that the yellow plastic combs are placed at the left of the first device and at the right of the last device in the system and have not been removed.
- ◆ Setup of the devices only with closed protective covers.

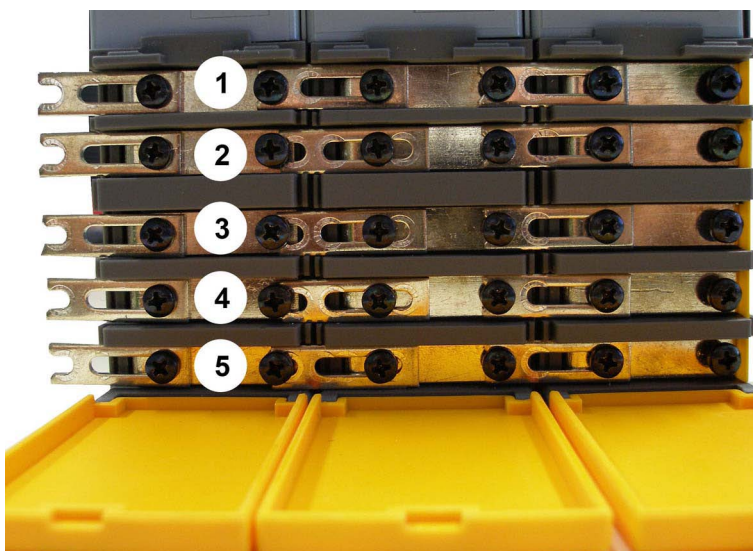

- | | |
|---|--------|
| 1 | 24VDC |
| 2 | GND24V |
| 3 | -HV DC |
| 4 | PE |
| 5 | +HV DC |

Note: External components **may not** be connected to the rail system.

Maximum capacity in the axis system:

- ◆ PSUP10: 2400 µF
- ◆ PSUP20 & PSUP30: 5000 µF

Reference value for the required capacity in an axis system

100 µF per kW of the temporal medium value of the total power (transmissions + power dissipation) in the axis system

Example: PSUP20 (1175 µF) with one axis controller (440 µF)

Total power 15 kW, 100 µF/kW => 1500 µF required in the axis system.
 Axis system: 1615 µF are sufficient.

Protective seals



Caution!

The user is responsible for protective covers and/or additional safety measures in order to prevent damages to persons and electric accidents.

3.6.4. Control voltage 24VDC PSUP (mains module)

Connector X9

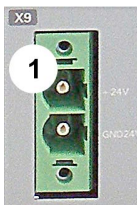

Pin	Designation
1	+24 V
2	GND24V

Line cross sections:
 minimum: 0.5mm² with conductor sleeve
 maximum: 6mm² with conductor sleeve
 (AWG: 20 ... 10)

Control voltage 24 VDC PSUP

Device type	PSUP
Voltage range	21 - 27VDC
Ripple	0.5Vpp
Requirement according to safe extra low voltage (SELV)	yes (class 2 mains module)
Current drain PSUP	PSUP10: 0.2A PSUP20 / PSUP30: 0.3A
Electric current drain Compax3M	C3M050D6: 0.85 3M100D6: 0.85A C3M150D6: 0.85A C3M300D6: 1.0 A + Total load of the digital outputs + current for the motor holding brake

3.6.5. Mains supply PSUP (mains module) X41

Device protection

By cyclically switching on and off the power voltage, the input current limitation can be overloaded, which may cause damage to the device.

Wait at least one minute between two switching on processes!

Operation of the PSUP30 only with mains filter!

Connector X41

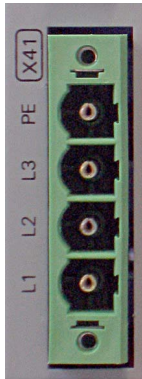

Pin	Designation
PE	Earth conductor
L3	Phase 3
L2	Phase 2
L1	Phase 1

Mains connection PSUP10D6

Device type PSUP10	230V	400V	480V
Supply voltage	230VAC ±10% 50-60Hz	400VAC ±10% 50-60Hz	480VAC ±10% 50-60Hz
Rated voltage	3AC 230V	3AC 400V	3AC 480V
Input current	22Arms	22Arms	18Arms
Output voltage	325VDC ±10%	565VDC ±10%	680VDC ±10%
Output power	6kW	10 kW	10 kW
Pulse power (<5s)	12kW	20kW	20kW
Power dissipation	60W	60W	60W
Maximum fuse rating per device (=short circuit rating)	Measure for line and device protection: MCB miniature circuit breaker (K characteristic) 25A in accordance with UL category DIVQ Recommendation: (ABB) S203UP-K25 (480VAC)		

Mains connection PSUP20D6

Device type PSUP20	230V	400V	480V
Supply voltage	230VAC ±10% 50-60Hz	400VAC ±10% 50-60Hz	480VAC ±10% 50-60Hz
Rated voltage	3AC 230V	3AC 400V	3AC 480V
Input current	44Arms	44Arms	35Arms
Output voltage	325VDC ±10%	565VDC ±10%	680VDC ±10%
Output power	12kW	20kW	20kW
Pulse power (<5s)	24kW	40kW	40kW
Power dissipation	120W	120W	120W
Maximum circuit breaker rating per device (=short circuit rating) 2 special purpose fuses in line are required	Cable protection measure: MCB (K characteristic) with a rating of 50A / 4xxVAC (depending on the input voltage) Recommendation: (ABB) S203P-K50 (440VAC) Device protection measure: Circuit breakers 80A / 700VAC per supply leg in accordance with UL category JFHR2 Requirement: Bussmann 170M1366 or 170M1566D		

PSUP30D6 Mains connection

Device type PSUP30	230V	400V	480V
Supply voltage	230VAC ±10% 50-60Hz	400VAC ±10% 50-60Hz	480VAC ±10% 50-60Hz
Rated voltage	3AC 230V	3AC 400V	3AC 480V
Input current	50Arms	50Arms	42Arms
Output voltage	325VDC ±10%	565VDC ±10%	680VDC ±10%
Output power	17kW	30kW	30kW
Pulse power (<5s)	34kW	60kW	60kW
Power dissipation	140W	140W	140W
Maximum circuit breaker rating per device (=short circuit rating) 2 special purpose fuses in line are required	Cable protection measure: MCB (K characteristic) with a rating of 63A / 4xxVAC (depending on the input voltage) Recommendation: (ABB) S203P-K63 (440VAC) Device protection measure: Circuit breakers 125A / 700VAC per supply leg in accordance with UL category JFHR2 Requirement: Bussmann 170M1368 or 170M1568D		

Caution!

Only three-phase operation of the PSUP devices is permitted!

The PSUP30 mains module may only be operated with mains filter

Required mains filter for the PSUP30: 0.45 mH / 55 A

We offer the following mains filters:

- ◆ LCG-0055-0.45 mH (WxDxH: 180 mm x 140 mm x 157 mm; 10 kg)
- ◆ LCG-0055-0.45 mH-UL (with UL approval) (WxDxH: 180 mm x 170 mm x 157 mm; 15 kg)

Dimensional drawing: LCG-0055-0.45 mH

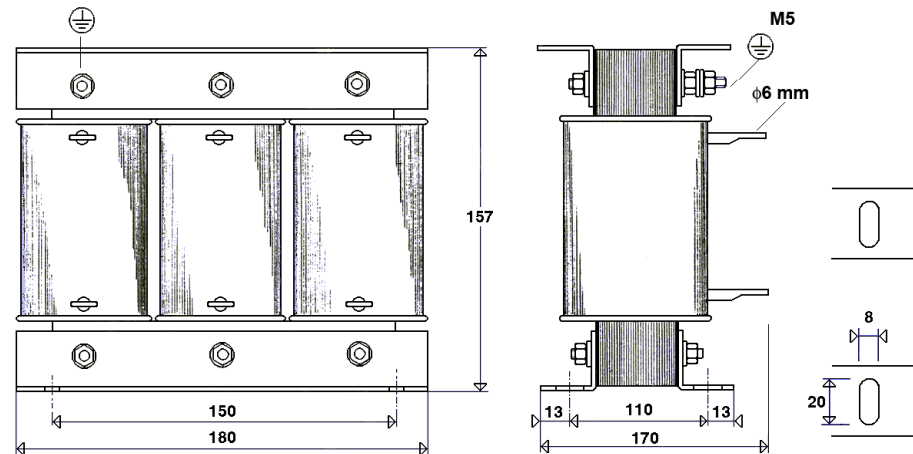

Dimensional drawing: LCG-0055-0.45 mH-UL

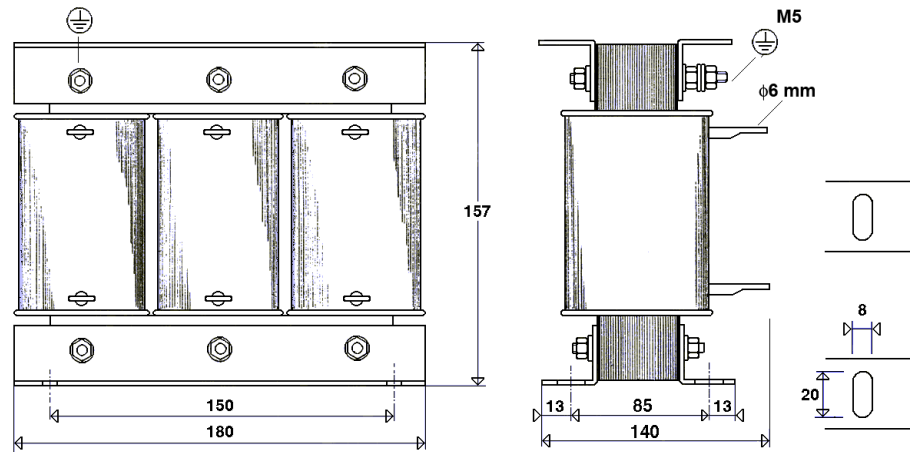

Caution - Risk of Electric Shock!

Always switch devices off before wiring them!

Dangerous voltages are still present until 10 min. after switching off the power supply.

3.6.6. Braking resistor / temperature switch PSUP (mains module)

The energy generated during braking operation must be dissipated via a braking resistor.

Connector X40

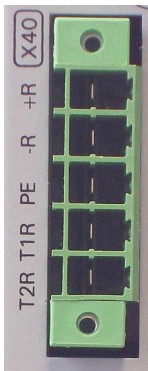

Pin	Description	
+R	+ Braking resistor	short-circuit proof!
-R	- Braking resistor	
PE	PE	
T1R	Temperature Switch	
T2R	Temperature Switch	

Braking operation PSUPxxD6 (mains module)

Device type	PSUP10	PSUP20	PSUP30
Capacitance / storable energy	550 µF/ 92 Ws at 400 V 53 Ws at 480 V	1175 µF/ 197 Ws at 400 V 114 Ws at 480 V	1175 µF/ 197 Ws at 400 V 114 Ws at 480 V
Minimum braking-resistance	27 Ω	15 Ω	10 Ω
Recommended nominal power rating	500 ... 1500 W	500 ... 3500 W	500 ... 5000 W
Pulse power rating for 1s	22 kW	40 kW	60 kW
Maximum permissible continuous current	13 A	15 A	15 A

Maximum capacity in the axis system:

- ◆ PSUP10: 2400 µF
- ◆ PSUP20 & PSUP30: 5000 µF

Reference value for the required capacity in an axis system

100 µF per kW of the temporal medium value of the total power (transmissions + power dissipation) in the axis system

Example: PSUP20 (1175 µF) with one axis controller (440 µF)

Total power 15 kW, 100 µF/kW => 1500 µF required in the axis system.

Axis system: 1615 µF are sufficient.

Connection of a braking resistor on PSUP (mains module)

Minimum line cross section:	1.5 mm ²
Maximum line length:	2 m
Maximum intermediate circuit voltage:	810 VDC
Switch-on threshold:	780 VDC
Hysteresis	20 VDC

Braking operation Compax3MxxxD6 (axis controller)

Device type Compax3	M050	M100	M150	M300
Capacity/ storable energy	110µF/ 18Ws at 400V 10Ws at 480V	220µF/ 37Ws at 400V 21Ws at 480V	220µF/ 37Ws at 400V 21Ws at 480V	440µF/ 74Ws at 400V 42Ws at 480V

3.6.6.1 Temperature switch PSUP (mains module)

Connector X40 Pin T1R, T2R

Temperature monitoring:

The temperature switch (normally closed contact) must be connected, unless an error message will be issued.

Temperature switch/relay

No galvanic separation, the temperature sensor (normally closed contact) must comply with the safe separation according to EN 60664.

If there is no temperature monitoring due to the connected braking resistor, the T1R and T2R connections must be connected by a jumper.



Caution!

Without temperature monitoring, the braking resistor might be destroyed.

3.6.7. Motor / motor brake Compax3M (axis controller)

Connector X43



PIN	Designation	Motor cable lead designation*		
BR-	Motor holding brake *	BK	5	Br2
BR+	Motor holding brake *	WH	4	Br1
PE	PE (motor)	YE / GN	YE / GN	YE / GN
W	W (motor)	W / L3 / D / L-	3	U3
V	V (motor)	V / L2	2	U2
U	U (motor)	U / L1 / C / L+	1	U1

* depending on the cable type

Compax3M motor cable

<80m per axis (the cable must not be rolled up!)

The entire length of the motor cable per axis combination may not exceed 300m.

A motor output filter is required for motor cables >20 m:

- ◆ MDR01/04 (max. 6.3 A rated motor current)
- ◆ MDR01/01 (max. 16 A rated motor current)
- ◆ MDR01/02 (max. 30 A rated motor current)

Shielding connection of the motor cable

The cable must be fully-screened and connected to the Compax3 housing. Use the cable clamps/shield connecting terminals furnished with the device.

The shield of the cable must also be connected with the motor housing. The fixing (via plug or screw in the terminal box) depends on the motor type.



Motor cables can be found in the accessories chapter of the device description.

Motor holding brake output

Motor holding brake output	Compax3
Voltage range	21 – 27VDC
Maximum output current (short circuit proof)	1.6A



Attention - Please wire the motor holding brake!

Connect the brake only on motors which have a holding brake! Otherwise make no brake connections at all.

Requirements cables for motor holding brake

If a motor holding brake is present, **one cable** of the motor holding brake must be fed on the device side through the toroidal core ferrite provided as accessory ZBH0x/xx (63Ω @1MHz, di=5.1mm), in order to ensure error-free switching on and off of the motor holding brake.

3.6.7.1 Measurement of the motor temperature of Compax3M (axis controller)

Connector X15

The acquisition of the motor temperature by the axis controller can either take place via the connection of X15 (Tmot) or via the feedback cable and the corresponding connection on X13 PIN10.

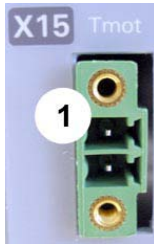

Pin	Description
1	+5V
2	Sensor

The temperature acquisition on X15 Tmot can not be connected at the same time as X13 Pin 10.

3.6.8. Safety technology option for Compax3M (axis controller)

Connector X14



Pin	Description	
1	STO1/	+24VDC
2	STO-GND	GND
3	STO2/	+24VDC
4	STO-GND	GND



Note!

If the Compax3M axis controller features a safety option, these connections must also be wired, otherwise it is not possible to set up the axis.

3.7 Communication interfaces

3.7.1. Communication Compax3M

In this chapter you can read about:

PC - PSUP (Mains module).....	38
Communication in the axis combination (connector X30, X31)	39
Adjusting the basic address	39
Setting the axis function	40

3.7.1.1 PC - PSUP (Mains module)

Connector X3



USB2.0

Connect your PC to the USB sleeve X3 of the mains module via an USB cable (SSK33/03).

3.7.1.2 Communication in the axis combination (connector X30, X31)

The communication in the axis combination is implemented via a SSK28 cable and double RJ45 sleeves on the device top.

Beginning with the PSUP (mains module) the connection is always made from X30 to X31 of the next device. On the first device (X31) and the last device (X30) in the multi-axis combination, a bus termination plug (BUS07/01) is required.

Orientation to the back side

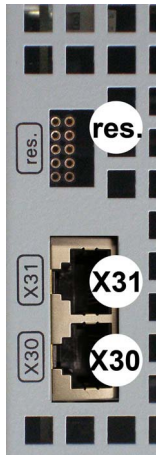

	PSUP (Mains module)
X30	out
X31	in
res.	factory use
	Compax3M (axis)
X30	out
X31	in
res.	factory use

Orientation to the front plate

3.7.1.3 Adjusting the basic address

On the mains module, the basic address of the device combination is set in steps of 16 with the aid of the first three dip switches.

The mains module contains the set basic address while the axes placed at the right in the combination contain the following addresses.

Switch S1

Address setting



Basic addresses

Switch	Value upon ON
1	16
2	32
3	64

Settings:

left: OFF
right: ON

Settable value range: 0, 16, 32, 48, 64, 80, 96, 112

Address of the 1st axis = basic address+1

The addresses of the axis controllers are newly assigned after PowerOn.

Example:

Basic address = 48; mains module with 6 axis controllers in the combination

- 1. Axis right: Address = 49
- 2. Axis right: Address = 50
- ...
- 6. Axis right: Address = 54

3.7.1.4 Setting the axis function

Switch S10



Function settings for T30 and T40

The value of switch S10 on the axis controller is stored in object O110.1 C3plus.Switch_DeviceFunction and can be evaluated with the aid of a program.

This helps realize a more simple function selection.

Autoryzowany dystrybutor Parker:

ARA

PNEUMATIK

53-012 Wrocław tel. 71 364 72 82
ul. Wyścigowa 38 fax 71 364 72 83

www.arapneumatik.pl



3.8 Signal interfaces

In this chapter you can read about:

Resolver / feedback (plug X13).....	41
Analogue / encoder (plug X11).....	42
Digital inputs/outputs (plug X12).....	43

3.8.1. Resolver / feedback (plug X13)

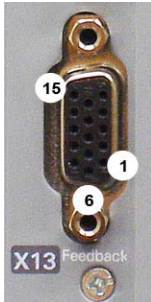

PIN X13	Feedback /X13 High Density /Sub D (depending on the Feedback module)		
	Resolver (F10)	SinCos (F11)	EnDat 2.1 (F12)
1	factory use	factory use	Sense -*
2	factory use	factory use	Sense +*
3	GND	GND	factory use
4	REF-Resolver+	Vcc (+8V)	Vcc (+5V) * max. 350mA load
5	+5V (for temperature sensor)		
6	factory use	factory use	CLKfbk
7	SIN-	SIN-	SIN- / A- (Encoder)
8	SIN+	SIN+	SIN+ / A+ (Encoder)
9	factory use	factory use	CLKfbk/
10	Tmot*	Tmot*	Tmot*
11	COS-	COS-	COS- / B- (Encoder)
12	COS+	COS+	COS+ / B+ (Encoder)
13	factory use	DATAfbk	DATAfbk
14	factory use	DATAfbk/	DATAfbk/
15	REF-Resolver-	GND (Vcc)	GND (Vcc)

*X13 Pin10 Tmot may not be connected at the same time as X15 (on Compaxx3M).

Resolver cables can be found in the accessories chapter of the device description.
SinCos® cables can be found in the accessories chapter of the device description.
The EnDat cable GBK38 can be found in the accessories chapter of the device description.

PIN X13	Feedback /X13 High Density /Sub D
	Direct drives (F12)
1	Sense -*
2	Sense +*
3	Hall1 (digital)
4	Vcc (+5V)* max. 350 mA load
5	+5 V (for temperature sensors und Hallsensoren)
6	Hall2 (digital)
7	SIN-, A- (Encoder) or analog Hall sensor
8	SIN+, A+, (Encoder) or analog Hall sensor
9	Hall3 (digital)
10	Tmot*
11	COS-, B- (Encoder) or analog Hall sensor
12	COS+, B+ (Encoder) or analog Hall sensor
13	N+
14	N-
15	GND (Vcc)

*X13 Pin10 Tmot may not be connected at the same time as X15 (on Compaxx3M).

Note on F12:

*+5V (Pin 4) is measured and controlled directly at the end of the line via Sense+ and Sense-.

Maximum cable length: 100m

Caution!

- ◆ Pin 4 and Pin 5 must under no circumstances be connected!
- ◆ Plug in or pull out feedback connector only in switched off state (24VDC switched off).

3.8.2. Analogue / encoder (plug X11)

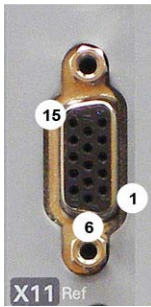

PIN X11	Reference High Density Sub D		
		Encoders	SSI
1	+24V (output) max. 70mA		
2	Ain1 -: analog input - (14Bits; max. +/-10V)		
3	D/A monitor channel 1 ($\pm 10V$, 8-bit resolution)		
4	D/A monitor channel 0 ($\pm 10V$, 8-bit resolution)		
5	+5 V (output for encoder) max. 150 mA		
6	- Input: steps RS422 (5V - level)	A/ (Input / -simulation)	Clock-
7	+ Input: steps RS422 (5V - level)	A/ (Input / -simulation)	Clock+
8	+ Input: direction RS422 (5V - level)	B Input / -simulation)	
9	Ain0 +: analog input + (14Bits; max. +/-10V)		
10	Ain1 +: analog input + (14Bits; max. +/-10V)		
11	Ain0 -: analog input- (14Bits; max. +/-10V)		
12	- Input: direction RS422 (5V - level)	B/ input / -simulation)	
13	factory use	N/ input / -simulation)	DATA-
14	factory use	N input / -simulation)	DATA+
15	GND		

Technical Data X11 (see on page 47)

3.8.2.1 Wiring of analog interfaces

Output Input

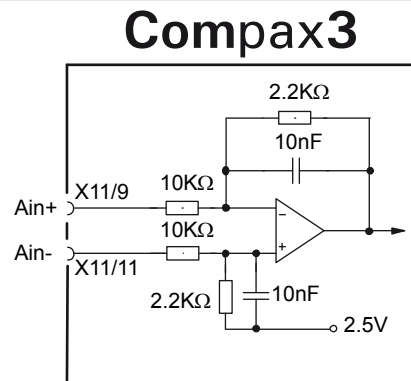
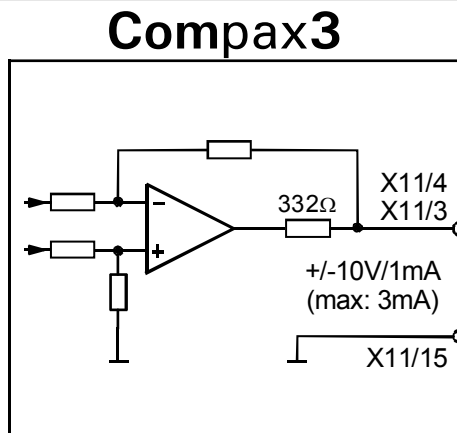

Perform an offset adjustment!

Structure image of the internal signal processing of the analog inputs
Ain1 (X11/10 and X11/2) has the same wiring!

3.8.2.2 Connections of the encoder interface

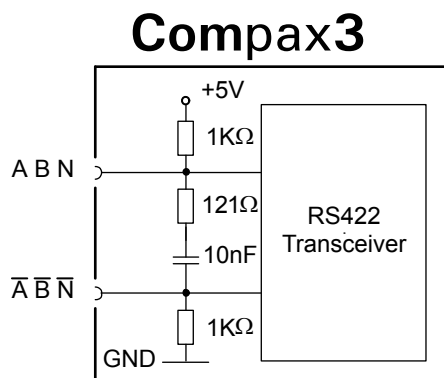

The input connection is available in triple (for A & /A, B & /B, N & /N)

3.8.3. Digital inputs/outputs (plug X12)

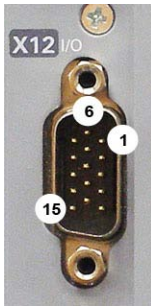

Pin X12	Input/output	I/O / X12 High density/Sub D
1	Output	+24 V DC output (max. 340mA)
2	O0	Output 0 (max. 100 mA)
3	O1	Output 1 (max. 100mA)
4	O2	Output 2 (max. 100mA)
5	O3	Output 3 (max. 100mA)
6	I0	Input 0
7	I1	Input 1
8	I2	Input 2
9	I3	Input 3
10	I4	Input 4
11	I	24V input for the digital outputs Pins 2 to 5
12	I5	Input 5
13	I6	Input 6
14	I7	Input 7
15	Output	GND24V

All inputs and outputs have 24V level.

The exact assignment depends on the the device type!

You will find the description of the device-specific assignment in the online help which can be opened from the Compax3 ServoManager.

Maximum capacitive loading of the outputs: 30nF (max. 2 Compax3 inputs).

3.8.3.1 Connection of the digital Outputs/Inputs

Wiring of digital outputs

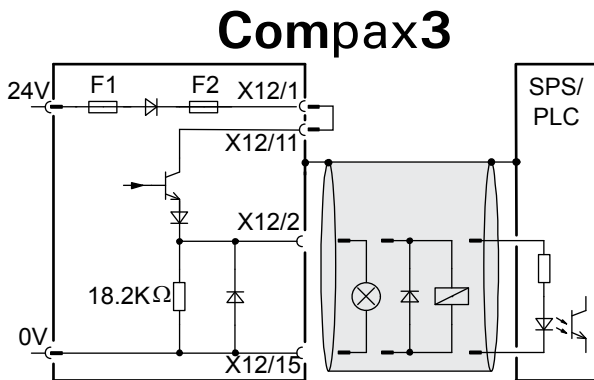

The circuit example is valid for all digital outputs!
The outputs are short circuit proof; a short circuit generates an error.

Status of digital inputs

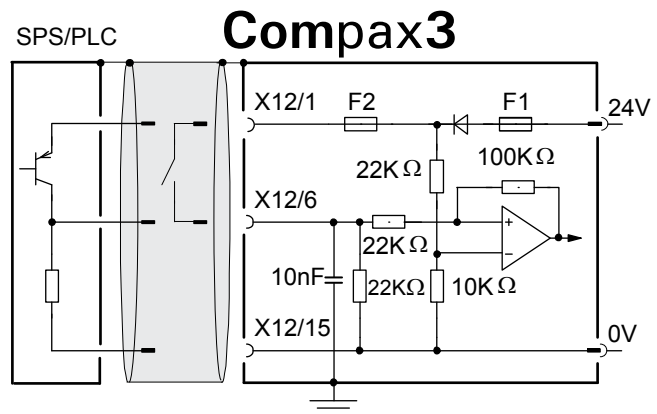

The circuit example is valid for all digital inputs!

Signal level:

- ◆ > 9.15V = "1" (38.2% of the control voltage applied)
- ◆ < 8.05V = "0" (33.5% of the control voltage applied)

F1: Delayed action fuse

F2: Quick action electronic fuse; can be reset by switching the 24 VDC supply off and on again.

4. Technical Characteristics

Size / weight PSUP/Compax3M

Device type	Dimensions HxWxD [mm]	Weight [kg]
PSUP10D6	360 x 50 x 263	3.95
PSUP20D6 & PSUP30D6	360 x 100 x 263	6.3
Compax3M050D6	360 x 50 x 263	3.5
Compax3M100D6	360 x 50 x 263	3.6
Compax3M150D6	360 x 50 x 263	3.6
Compax3M300D6	360 x 100 x 263	5.25

Protection type IP20

Mains connection PSUP10D6

Device type PSUP10	230V	400V	480V
Supply voltage	230VAC ±10% 50-60Hz	400VAC ±10% 50-60Hz	480VAC ±10% 50-60Hz
Rated voltage	3AC 230V	3AC 400V	3AC 480V
Input current	22Arms	22Arms	18Arms
Output voltage	325VDC ±10%	565VDC ±10%	680VDC ±10%
Output power	6kW	10 kW	10 kW
Pulse power (<5s)	12kW	20kW	20kW
Power dissipation	60W	60W	60W
Maximum fuse rating per device (=short circuit rating)	Measure for line and device protection: MCB miniature circuit breaker (K characteristic) 25A in accordance with UL category DIVQ Recommendation: (ABB) S203UP-K25 (480VAC)		

Mains connection PSUP20D6

Device type PSUP20	230V	400V	480V
Supply voltage	230VAC ±10% 50-60Hz	400VAC ±10% 50-60Hz	480VAC ±10% 50-60Hz
Rated voltage	3AC 230V	3AC 400V	3AC 480V
Input current	44Arms	44Arms	35Arms
Output voltage	325VDC ±10%	565VDC ±10%	680VDC ±10%
Output power	12kW	20kW	20kW
Pulse power (<5s)	24kW	40kW	40kW
Power dissipation	120W	120W	120W
Maximum circuit breaker rating per device (=short circuit rating) 2 special purpose fuses in line are required	Cable protection measure: MCB (K characteristic) with a rating of 50A / 4xxVAC (depending on the input voltage) Recommendation: (ABB) S203P-K50 (440VAC) Device protection measure: Circuit breakers 80A / 700VAC per supply leg in accordance with UL category JFHR2 Requirement: Bussmann 170M1366 or 170M1566D		

PSUP30D6 Mains connection

Device type PSUP30	230V	400V	480V
Supply voltage	230VAC ±10% 50-60Hz	400VAC ±10% 50-60Hz	480VAC ±10% 50-60Hz
Rated voltage	3AC 230V	3AC 400V	3AC 480V
Input current	50Arms	50Arms	42Arms
Output voltage	325VDC ±10%	565VDC ±10%	680VDC ±10%
Output power	17kW	30kW	30kW
Pulse power (<5s)	34kW	60kW	60kW
Power dissipation	140W	140W	140W
Maximum circuit breaker rating per device (=short circuit rating) 2 special purpose fuses in line are required	Cable protection measure: MCB (K characteristic) with a rating of 63A / 4xxVAC (depending on the input voltage) Recommendation: (ABB) S203P-K63 (440VAC) Device protection measure: Circuit breakers 125A / 700VAC per supply leg in accordance with UL category JFHR2 Requirement: Bussmann 170M1368 or 170M1568D		

Control voltage 24 VDC PSUP

Device type	PSUP
Voltage range	21 - 27VDC
Ripple	0.5Vpp
Requirement according to safe extra low voltage (SELV)	yes (class 2 mains module)
Current drain PSUP	PSUP10: 0.2A PSUP20 / PSUP30: 0.3A
Electric current drain Compax3M	C3M050D6: 0.85 3M100D6: 0.85A C3M150D6: 0.85A C3M300D6: 1.0 A + Total load of the digital outputs + current for the motor holding brake

Output data Compax3Mxxx at 3*230VAC

Device type Compax3	M050D6	M100D6	M150D6	M300D6
Input voltage	325VDC ±10%			
Output voltage	3x 0-230V (0...500Hz)			
Nominal output current	5Arms	10Arms	15Arms	30Arms
Pulse current for 5s*	10Arms	20Arms	30Arms	60Arms
Power	2kVA	4kVA	6kVA	12kVA
Switching frequency	8kHz	8kHz	8kHz	8kHz
Power loss for In	70W ^{***}	90W ^{***}	120W ^{***}	270W ^{***}

*Electrical turning frequency for pulse current: f>5 Hz; with an electrical turning frequency of f<5 Hz, the maximum pulse current time is 100ms

** Maximum additional losses with option card 5 W.

Output data Compax3Mxxx at 3*400VAC

Device type Compax3	M050D6	M100D6	M150D6	M300D6
Input voltage	565VDC ±10%			
Output voltage	3x 0-400V (0...500Hz)			
Nominal output current	5Arms	10Arms	15Arms	30Arms
Pulse current for 5s*	10Arms	20Arms	30Arms	60Arms
Power	3.33kVA	6.66kVA	10kVA	20kVA
Switching frequency	8kHz	8kHz	8kHz	8kHz
Power loss for In	70W+**	90W+**	120W+**	270W+**

*Electrical turning frequency for pulse current: f>5 Hz; with an electrical turning frequency of f<5 Hz, the maximum pulse current time is 100ms

** Maximum additional losses with option card 5 W.

Output data Compax3Mxxx at 3*480VAC

Device type Compax3	M050D6	M100D6	M150D6	M300D6
Input voltage	680VDC ±10%			
Output voltage	3x 0-480V (0...500Hz)			
Nominal output current	4Arms	8Arms	12.5Arms	25Arms
Pulse current for 5s*	8Arms	16Arms	25Arms	50Arms
Power	3.33kVA	6.66kVA	10kVA	20kVA
Switching frequency	8kHz	8kHz	8kHz	8kHz
Power loss for In	70W+**	90W+**	120W+**	270W+**

*Electrical turning frequency for pulse current: f>5 Hz; with an electrical turning frequency of f<5 Hz, the maximum pulse current time is 100ms

** Maximum additional losses with option card 5 W.

Resolution of the motor position

For option F10: Resolver	<ul style="list-style-type: none"> ◆ Position resolution: 16 Bits (= 0.005°) ◆ Absolute accuracy: ±0.167°
For option F11: SinCos®	<ul style="list-style-type: none"> ◆ Position resolution: 13.5 Bits / Encoder sine period => 0.03107°/encoder resolution
For option F12:	<ul style="list-style-type: none"> ◆ Maximum position resolution <ul style="list-style-type: none"> ◆ Linear: 24 Bits per motor magnet spacing ◆ Rotary: 24 Bits per motor revolution ◆ Resolution for Sine-Cosine encoders (e.g. EnDat) with 1Vss signal): <ul style="list-style-type: none"> 13.5 bits / graduation of the scale of the encoder ◆ For RS 422 encoders: 4x encoder resolution ◆ Accuracy of the feedback zero pulse acquisition = accuracy of the feedback resolution. ◆ Resolution for analog hall sensors with 1Vss signal: <ul style="list-style-type: none"> 13.5 Bits / motor magnet spacing

Accuracy

The exactitude of the position signal is above all determined by the exactitude of the feedback system used.

Motors and feedback systems supported

Motors Direct drives ◆ Linear motors ◆ Torque motors	◆ Sinusoidally commutated synchronous motors ◆ Maximum electrical turning frequency: 1000Hz* ◆ Max. velocity at 8 pole motors: 15000min ⁻¹ . ◆ General max. Velocity: 60*1000/number of pole pairs in [min ⁻¹]. ◆ Max. number of poles = 600 ◆ Sinusoidal commutated asynchronous motors ◆ Maximum electrical turning frequency: 1000Hz ◆ Max. velocity: 60*1000/number of pole pairs - slip in [min ⁻¹]. ◆ Field weakening: typically up to triple (higher on request). ◆ Temperature sensor: KTY84-130 (insulated in accordance with EN60664-1 or IEC60664-1) ◆ 3 phase synchronous direct drives
Position encoder (Feedback)	Option F10: Resolver
LTN:	◆ RE-21-1-A05, RE-15-1-B04
Tamagawa:	◆ TS2610N171E64, TS2620N21E11, TS2640N321E64, TS2660N31E64
Tyco (AMP)	◆ V23401-T2009-B202
	Option F11: SinCos®
	◆ Rotary feedback with HIPERFACE® interface: ◆ Singleturn (SICK Stegmann) ◆ Multiturn (SICK Stegmann) Absolute position up to 4096 motor revolutions. ◆ For example: SRS50, SRM50, SKS36, SKM36, SEK52, SEL52, SEL37, SEK37, SEK160, SEK90

* higher values on request

Special encoder systems for direct drives	Option F12
Analog hall sensors	◆ Sine-Cosine signal (max. 5Vss*; typical 1Vss) 90° offset ◆ U-V signal (max. 5Vss*; typical 1Vss) 120° offset.
Encoder (linear or rotatory)	◆ Sine-Cosine (max. 5Vss*; typical 1Vss) (max. 400kHz) or ◆ TTL (RS422) (max. 5MHz; track A or B) ◆ Bypass function for encoder signals (limit frequency** 5MHz, track A or B) with the following modes of commutation: ◆ Automatic commutation or ◆ U, V, W or R, S, T commutation signals (NPN open collector) e.g. digital hall sensors, incremental encoders made by Hengstler (F series with electrical ordering variant 6)
Digital, bidirectional interface	◆ All EnDat 2.1 or EnDat 2.2 (Endat01, Endat02) feedback systems with incremental track (sine-cosine track) ◆ linear or rotary ◆ max. 400kHz Sine-Cosine
Distance coded feedback systems	◆ Distance coding with 1VSS - Interface ◆ Distance coding with RS422 - Interface (Encoder)

*Max. differential input between SIN- (X13/7) and SIN+ (X13/8).

** Limit frequency = 1MHz for Compax3M (higher bandwidths on request)

Motor holding brake output

Motor holding brake output	Compax3
Voltage range	21 – 27VDC
Maximum output current (short circuit proof)	1.6A
Securing of brake Compax3M	3.15A

UL-approval for PSUP/Compax3M

conform to UL:	◆ according to UL508C
Certified	◆ E-File_No.: E235342

The UL certification is documented by a “UL” logo on the device (type specification plate).



Insulation requirements

Enclosure rating	Protection class in accordance with EN 60664-1
Protection against human contact with dangerous voltages	In accordance with EN 61800-5-1
Overvoltage category	Voltage category III in accordance with EN 60664-1
Degree of contamination	Degree of contamination 2 in accordance with EN 60664-1 and EN 61800-5-1

Safety technology Compax3M

Safe torque-off in accordance with EN ISO 13849-1: 2007, Category 3, PL=e Certified. Test mark MFS 09029	◆ Please respect the stated safety technology on the type designation plate (see on page 9) and the circuitry examples
---	---

Compax3M S1 Option: Signal inputs for connector X14

Nominal voltage of the inputs	24V
Required isolation of the 24V control voltage	Grounded protective extra low voltage, PELV
Protection of the STO control voltage	1A
Number of inputs Signal inputs via optocoupler	2 Low = 0...7V DC or open High = 15...30V DC I_{in} at 24V DC: 8mA
STO1/	Low = STO activated High = STO deactivated Reaction time max. 3ms
STO2/	Low = STO activated High = STO deactivated Reaction time max. 3ms
Switch-off time with unequal input statuses (max. reaction time)	20 seconds
Grouping of safety level	Category 3 PL=e (according to table 4 in EN ISO 13849-1 this corresponds to SIL 3) PFHd=4.29E-8

Ambient conditions PSUP/Compax3M

General ambient conditions	In accordance with EN 60 721-3-1 to 3-3 Climate (temperature/humidity/barometric pressure): Class 3K3	
Permissible ambient temperature:	Class 3K3	
Operation	0 to +40 °C	
storage	-25 to +70 °C	
transport	-25 to +70 °C	
Tolerated humidity:	no condensation	
Operation	<= 85% class 3K3	(Relative humidity)
storage	<= 95%	
transport	<= 95%	
Elevation of operating site	<=1000m above sea level for 100% load ratings <=2000m above sea level for 1% / 100m power reduction please inquire for greater elevations	
Sealing	Protection type IP20 in accordance with EN 60 529	
Mechanic resonances:	Class 2M3, 20m/s ² ;8-200Hz	

Cooling PSUP/Compax3M

Cooling mode:	Forced air ventilation with fan in the heat dissipator
---------------	--

EMV limit values PSUP/Compax3M

EMC interference emission	Limit values in accordance with EN 61 800-3, Limit value class C3 with mains filter.
EMC disturbance immunity	Industrial area limit values in accordance with EN 61 800-3

EC directives and applied harmonized EC norms

EC low voltage directive 2006/95/EG	EN 61800-5-1 , Standard for electric power drives with settable speed; requirements to electric safety EN 60664-1 , isolation coordinates for electrical equipment in low-voltage systems EN 60204-1 , machinery norm partly applied
EC-EMC-directive 2004/108/EC	EN 61800-3 , EMC standard Product standard for variable speed drives

Detailed information on the technical data of the Compax3 devices can be found in the Help- or PDF-files of the individual Compax3 device types.

5. Index

A

Additional conditions of utilization - 17
 Adjusting the basic address - 39
 Analogue / encoder (plug X11) - 42

B

Braking resistor / temperature switch PSUP (mains module) - 35

C

C3 ServoManager - 4
 Capacitors - 12
 Communication Compax3M - 38
 Communication in the axis combination (connector X30, X31) - 39
 Communication interfaces - 38
 Conditions of utilization - 16
 Conditions of utilization for cables / motor filter - 17
 Conditions of utilization for CE-conform operation - 16
 Conditions of utilization for UL certification Compax3M - 19
 Conditions of utilization mains filter - 16
 Connection of the digital Outputs/Inputs - 43
 Connections of the axis combination - 31
 Connections of the encoder interface - 42
 Connections on the device bottom - 30
 Control voltage 24VDC PSUP (mains module) - 32
 Current on the mains PE (leakage current) - 20

D

Device assignment - 8
 Device description - 24
 Digital inputs/outputs - 43
 Digital inputs/outputs (plug X12) - 43

E

EC declaration of conformity Compax3M - 22
 EC declaration of conformity PSUP - 23

F

Front connector - 29

G

General hazards - 13

I

Installation instructions Compax3M - 24
 Introduction - 8

L

LEDs - 28

Level - 43

M

Mains supply PSUP (mains module) X41 - 32
 Meaning of the status LEDs - Compax3 axis controller - 28
 Meaning of the status LEDs - PSUP (mains module) - 28
 Measurement of the motor temperature of Compax3M (axis controller) - 38
 Motor / motor brake Compax3M (axis controller) - 37
 Mounting and dimensions - 26
 Mounting and dimensions PSUP10/C3M050D6, C3M100D6, C3M150D6 - 26
 Mounting and dimensions PSUP20/PSUP30/C3M300D6 - 27

N

Notes on the Documents Supplied - 3

P

Packaging, transport, storage - 11
 PC - PSUP (Mains module) - 38
 Plug assignment Compax3S0xx V2 - 41
 PSUP/Compax3M Connections - 29

R

Resolver - 41
 Resolver / feedback (plug X13) - 41

S

Safety instructions - 13
 Safety technology option for Compax3M (axis controller) - 38
 Safety-conscious working - 13
 Scope of delivery - 8
 Setting the axis function - 40
 Signal interfaces - 41
 Special safety instructions - 14
 State of delivery - 28
 Status LEDs - 28
 Storage - 12
 Supply networks - 21

T

Technical Characteristics - 44
 Temperature switch PSUP (mains module) - 36
 Type specification plate - 9

U

Usage in accordance with intended purpose - 13

W

Warranty conditions - 15

Wiring of analog interfaces - 42

With upper mounting, the housing design may
be different - 27

X

X11 - 42

X12 - 43

X13 - 41

Autoryzowany dystrybutor Parker:

ARA
PNEUMATIK

53-012 Wrocław tel. 71 364 72 82
ul. Wyścigowa 38 fax 71 364 72 83

www.arapneumatik.pl

