

ER PREMIER

Electric actuator



A WATTS Brand



UK Installation and Operation Manual



20Nm
⇓
100Nm

Indice de protection
IP65
Enclosure protection

Facteur de marche
30%
Duty cycle

ARA[®]
PNEUMATIK
ul. Wyciągowa 38, 53-012 Wrocław
tel. 71 364 72 82, ara@arapneumatik.pl
www.arapneumatik.pl



Index

General information	3
– Description	
– Transport and storage	
– Maintenance	
– Warranty	
– Return of goods	
– Safety instructions	
Position indicator	4
Emergency manual override	4
Dimensions	5
Electric wiring	6
– Warnings	
– Wiring Instructions	
– Electric diagram	
– Electronic boards	
Technical data	9

This product meets the European Directive 2012/19/UE about electrical and electronic equipment (DEEE). It mustn't be mixed with common waste. Please, recycle or dispose of them according to your country laws.

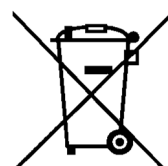

DESCRIPTION

These electric actuators have been designed to perform the control of a valve with 90° rotation. Please consult us for any different application. We cannot be held responsible if the mentioned actuators are used in contradiction to this advice..

TRANSPORT AND STORAGE

- The forwarding agents being held as responsible for damages and delays of the delivered goods, the consignees are obliged to express if applicable their reserves, prior to accept the goods. The goods delivered directly ex works are subject to the same conditions.
- The transport to the place of destination is carried out by using rigid packing material.
- The products must be stored in clean, dry, and ventilated places preferably on appropriate palettes or shelves.

MAINTENANCE

- Maintenance is ensured by our factory. If the supplied unit does not work, please check the wiring according to the electric diagram as well as the power supply of the concerned electric actuator.
- For any question, please contact our after-sales service.
- To clean the outside of the actuator, use a lint and soapy water. **DO NOT USE CLEANING PRODUCT WITH SOLVENT OR ALCOHOL**

WARRANTY

- Our products are thoroughly tested and set in factory.
- These products are 3-year warranty from the manufacturing site delivery date or 50,000 actuations against all types of manufacturing and material faults (operating time and model class according to standard CEI34).
- The said guarantee covers solely replacement or – at our full sole discretion - repair, free of charge, of those components of the goods supplied which in our sole view present proven manufacturing defects.
- This warranty excludes any damage due to normal product usage or friction and does not include any modified or unauthorized repair for which we will not accept any request for damage (either direct or indirect) compensation (for full details see our website).
- The guarantee does not cover the consequences of breakdown and excludes any payments for indemnities. The accessories, consumables (batteries...) and adaptations are excluded from the guarantee. In the case where a customer has not proceeded to payments within the agreed period, our guarantee will be suspended until the delayed payments have been received and with the consequence that this suspension will not prolong the guarantee period in any case.
- All sales subject to our terms to be found on our website.

RETURN OF GOODS

- The customer is obliged to check the conformity of the goods with regard to their definition at the time of delivery.
- The acceptance of the goods by the purchaser disclaims the supplier of all responsibility if the purchaser discovers any non-conformity after the date of acceptance. In such case, the repair cost will be borne by the purchaser who will also exclusively bear all financial consequences of any resulting damage. Returned goods will only be accepted if our prior agreement has been given to this procedure : the goods must be sent free of all cost and being shipped solely and in their original packing. The returned goods will be credited to the purchaser with a reduction of 40% on the unit's price charged in accordance with the original invoice of the returned goods.

SAFETY INSTRUCTIONS



To be read prior to the installation of the product

- The electric power supply must be switched-off before any intervention on the electric actuator (i.e. prior demounting its cover or manipulating the manual override knob).
- Any intervention must only be carried out by a qualified electrician or other person instructed in accordance with the regulations of electric engineering, safety, and all other applicable directives.
- Strictly observe the wiring and set-up instructions as described in the manual: otherwise, the proper working of the actuator can not be guaranteed anymore. Verify that the indications given on the identification label of the actuator fully correspond to the characteristics of the electric supply.



- Do not mount the actuator « upside down ». Risks:
 - Declutching mechanism failure
 - Possible flow of the grease on the electronic board
- Do not mount the actuator less than 30 cm of an electromagnetic disturbances source.
- Do not position the equipment so that it is difficult to operate the disconnecting device.

Position indicator

Handle with position indicator for ER20 and round indicator for ER 35/60/100

Modular position indicator with three removable position markers (3 yellow + 2 black), adjustable according the type of valve to be actuated

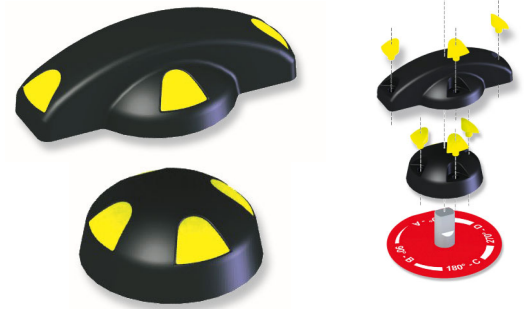

Valve	0°		90°		180°	
2-way: 0° = close 90° = open						
3-way (L):						
3-way (T): Ex: T1						

Emergency manual override



The priority functioning mode of this actuator is electric. Be sure that the power supply is switched off before using the manual override

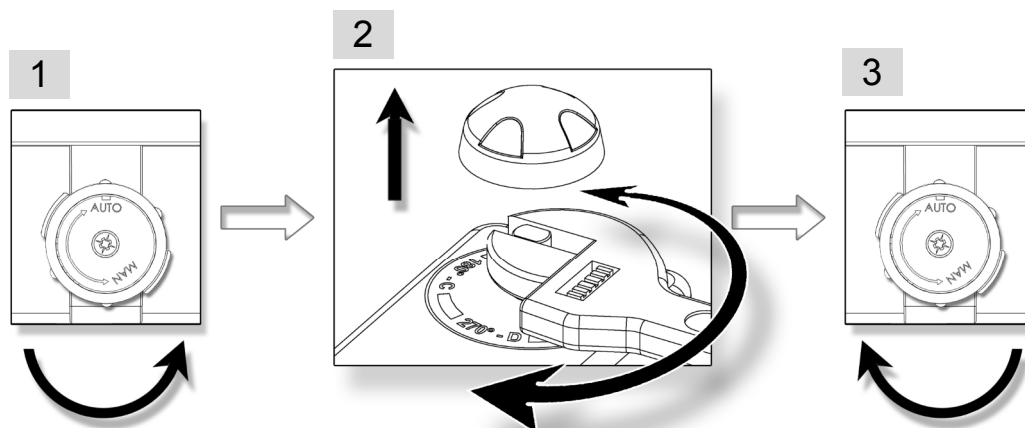

1. Turn the knob to position MAN (counter-clockwise) and hold it in position.
2. Turn the outgoing drive shaft of the actuator with the help of an adjusting spanner.
3. In order to re-engage the reduction, release the knob (spring return).

Dimensions

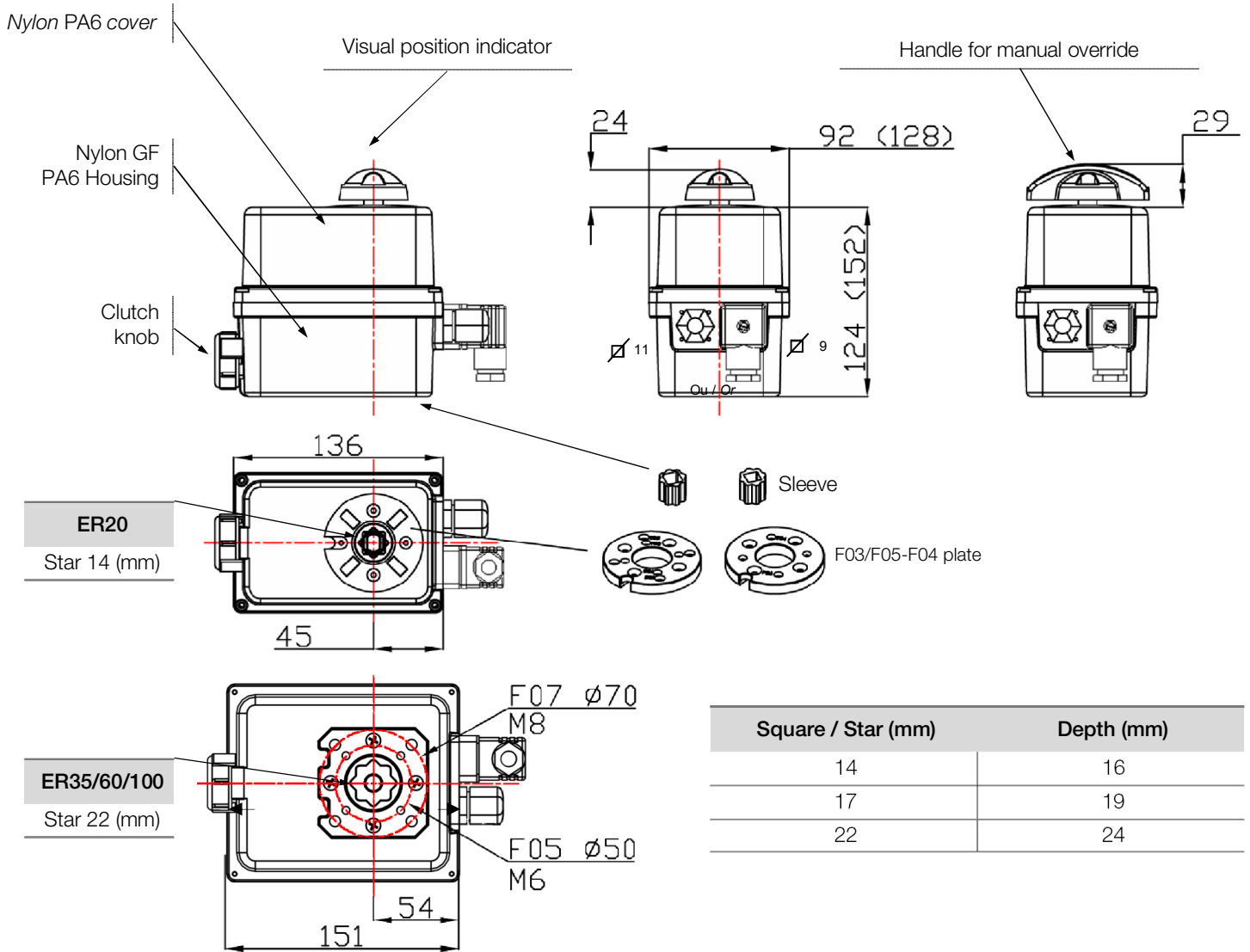

Square / Star (mm)	Depth (mm)
14	16
17	19
22	24

ISO F flange	Diameter (mm)	M threaded	Depth (mm)	Screws quantity
F03	36	M5	14.2	4
F04	42	M5	14.2	4
F05	50	M6	14.2 / 16.4	4
F07	70	M8	16.4	4

Electric wiring

Warnings



- As stipulated in the applicable regulation, the connection to earth contact is compulsory for devices with working voltages exceeding 42V.
- The actuator is always powered, so it must be connected to a disconnection system (switch, circuit breaker) to ensure the actuator power cut, correctly located, easily reached and marked as being the disconnecting device for the equipment.
- An inrush current may occur when actuators are switched on. Therefore it is necessary to limit the number of actuators on the same line. Alternatively an inrush current limiter at the output of the circuit breaker may be used.
- The terminal temperature can reach 90°C
- For a use with a long power supply wiring, the induction current generated by the wires mustn't be higher than 1mA
- In order to ensure the IP65 tightness, the cable gland for feedback wiring must be used (7 to 12mm cable). Otherwise, the cable gland must be replaced by a ISO M20 IP65 cap.

Instructions

Our cable glands are designed for cables with a diameter between 7mm and 12mm. The actuator can support MAINS supply voltage fluctuations up to $\pm 10\%$ of the nominal voltage. It is necessary to connect all actuators to an electrical cabinet

- Remove the position indicator, unscrew the four screws and take off the cover.

SUPPLY AND CONTROL WIRING

- Ensure that the voltage indicated on the actuator ID label corresponds to the voltage supply.
- Connect the wires to the connector in accordance with the required control mode. (see diagram p.15)
- To ensure the correct functioning of the anti-condensation heaters, the actuator must be permanently power supplied

WIRING OF THE FEEDBACK SIGNAL

Our actuators are equipped with two simple limit switch contacts normally set either in open position, either in closed position (see wiring diagram DSBA0436). As per factory setting, the white cam is used to detect the open position (FC1) and the black cam is used to detect the closed position (FC2).

The auxiliary limit switches must be connect with rigid wires. If the applied voltage is higher than 42V, the user must foresee a fuse in the power supply line.

The voltages applied to each feedback switch (FC1 and FC2, SNAA690000 electronic board) must be exactly the same .The reinforced insulation between the feedback signal and the motor control authorizes voltages up to 250V AC/DC.

- Unscrew the right cable gland and insert the cable.
- Remove 25mm of the cable sheath and strip each wire by 8mm.
- Connect the wires to the terminal strip in accordance with the diagram p.15
- Tighten the cable gland (Ensure that it's well mounted to guaranty the proofness).

SETTING OF END LIMIT SWITCHES

The actuator is pre-set in our factory. Do not touch the two lower cams in order to avoid any malfunctioning or even damage to the actuator.

- To adjust the position of the auxiliary contacts, make rotate the two superior cams by using the appropriate wrench.
- Re-mount the cover, fasten the four screws and attach the position indicator.



The terminal temperature can reach 90°C
 The used wires must be rigid (feedback voltages : 4 to 250V AC/DC)

REP	DESIGNATION		
FCO	Open limit switch	FC1	Auxiliary limit switch 1
FCF	Close limit switch	FC2	Auxiliary limit switch 2

POWER SUPPLY : 3P+T DIN43650 CONNECTOR

SUGGESTED CUSTOMER WIRING

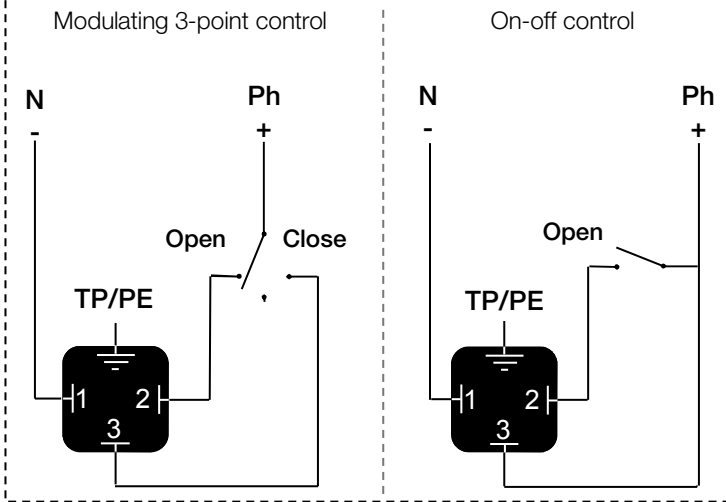

FEEDBACK

IF CONNECTOR OPTION (ECD.1A)

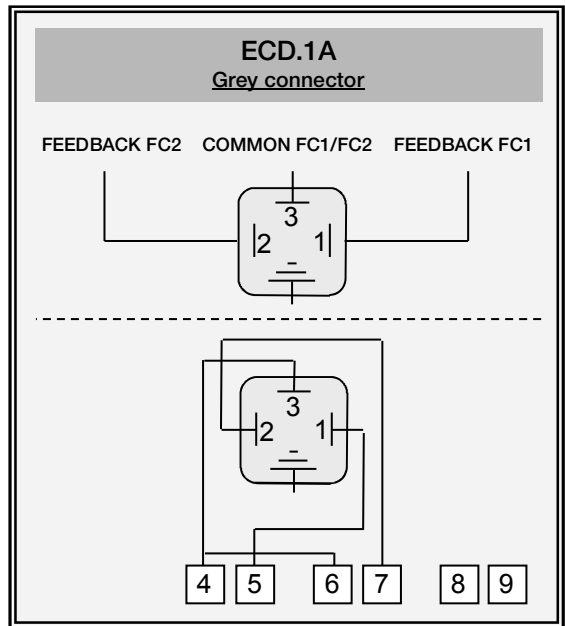

IF WIRING THROUGH THE CABLE GLAND

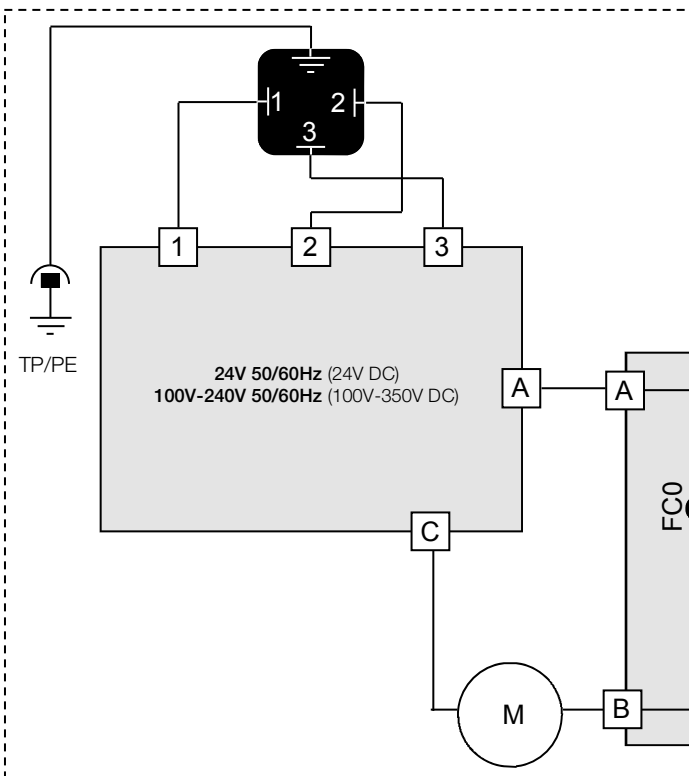
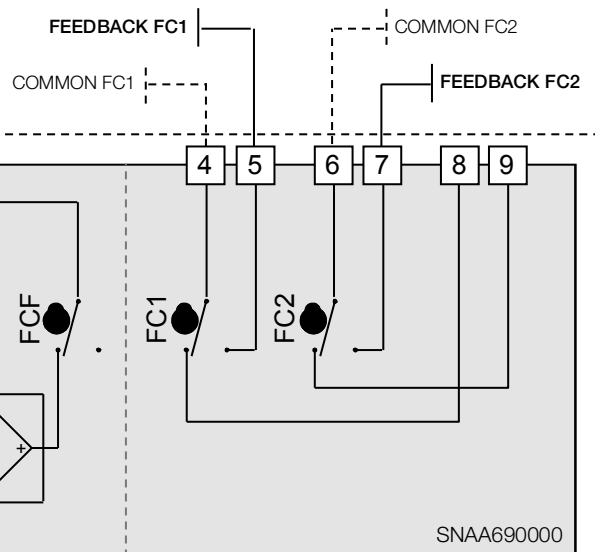

Electronic boards

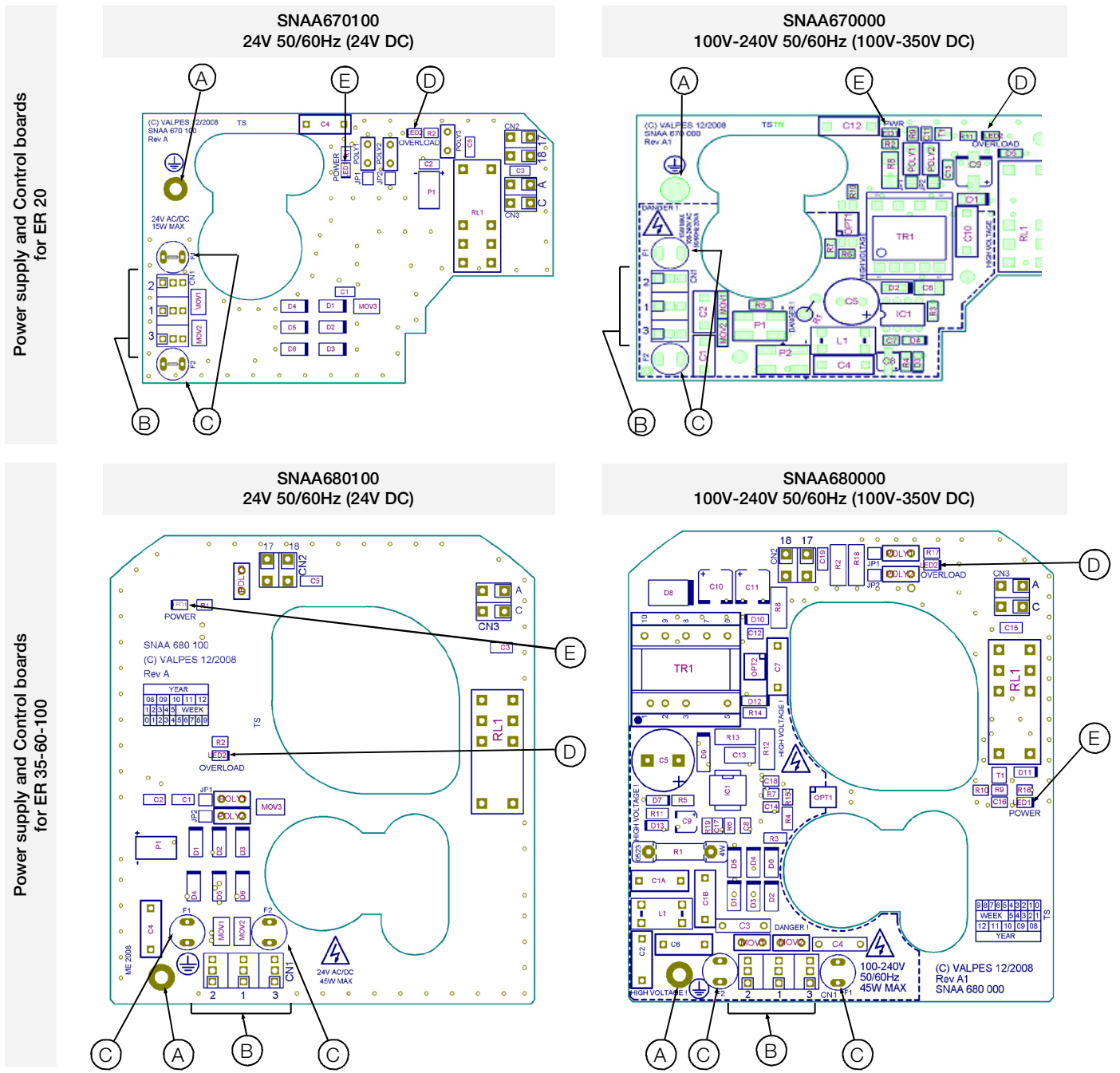

REP	DESIGNATION	REP	DESIGNATION
A	Earth screw	D**	LED 2 : detected failure
B	Power supply and control terminal	E	LED 1 : power supply presence
C*	Protection fuses		

- * Fuses for multivolt boards
- SNAAG70100 board: 1A / T (Schurter 0034.6615)
 - SNAAG70000 board: 500mA / T (Schurter 0034.6612)
 - SNAAG80100 board: 3.15A / T (Schurter 0034.6620)
 - SNAAG80000 board: 1A / T (Schurter 0034.6615)

** Possible defects : limitation of current, thermic limitation or program error
=> check that the valve torque is not superior to the maximum torque stand by the actuator
=> check that the actuator do not exceed the duty cycle indicated (possible overheat)
To re-start the actuator, reverse the sense of rotation or switch the power off and on.

TECHNICAL DATA

Type (1/4 turn electric actuator)	ER20	ER35	ER60	ER100
Housing type	Small housing (see p.13)	large housing (see p.13)		
IP protection (EN60529)	IP65			
Corrosion resistance (outdoor and indoor use)	Housing: PA6 UL94V0 + 25% GF and cover: PA6 UL94V0 Raw material : 304L Stainless Steel or Steel + Zn treatment			
Temperature	-10°C to +55°C			
Hygrometry	maximum relative humidity 80 % for temperatures up to 31 °C decreasing linearly to 50 % relative humidity at 40 °C			
Pollution degree	Applicable POLLUTION DEGREE of the intended environment is 2 (in most cases).			
Altitude	altitude up to 2 000 m			
Extended environmental conditions	Outdoor use and in WET LOCATION			
Sound level	61 dB			
Weight	1 Kg	2.1 Kg		

MECHANICAL DATA

Nominal torque	20Nm	35Nm	60Nm	100Nm
1/4 turn travel time	13s	8s	15s	25s
Mounting actuator base (ISO 5211)	Star 14 F03-F04-F05	Star 22 F05-F07		
Swing angle	90° (others on request)			
Mechanical end stops	90° +/- 5°			
Manual override	Out axle			
Direction of rotation	Anticlockwise to open			

ELECTRICAL DATA

Voltage ±10%	24V AC 50/60Hz or 100V to 240V AC 50/60Hz 24V DC or 100V to 350V DC			
Frequency	50/60Hz			
Power consumption	15W (0.08A) cos j = 0.75	45W (0.15A) cos j = 0.75		
Overvoltage category	TRANSIENT OVERVOLTAGES up to the levels of OVERVOLTAGE CATEGORY II TEMPORARY OVERVOLTAGES occurring on the MAINS supply			
Torque limiter	Electric			
Duty cycle (CEI34)	30%			
Limit switches maximal voltage	4 to 250V AC/DC (Overvoltage category II)			
Limit switches maximal current	1mA to 5A max			
Electrical wiring	1 ISO M20 cable gland and 1 DIN43650 3P+T connector			
Inrush current	Circuit breaker type D, nominal current according the number of actuators (max. 4 actuators) or use a inrush current limiter at the output of the circuit breaker.			