



## Electric actuator ER premier

Indice de protection

**IP65**

Enclosure protection

**20Nm**



**100Nm**

Facteur de marche

**30%**

Duty cycle

**ARA**<sup>®</sup>

**PNEUMATIK**

ul. Wyścigowa 38, 53-012 Wrocław  
tel. 71 364 72 82, ara@arapneumatik.pl

[www.arapneumatik.pl](http://www.arapneumatik.pl)



 **valpes**

**A WATTS Brand**

## Description

90° IP65 electric actuator, PA6 housing UL 94 VO with secured manual override for torques of 20-35-60-100Nm and in accordance with CE-ROHS-REACH standards.



### Technical datas

Visual position indicator	Modular (handle for ER20)
Control	On-Off or 3-modulating points
Voltages	24V AC (50/60Hz) & 24V DC or 100V to 240V AC (50/60Hz) & 100V to 350V DC
Duty cycle	Service S4 - 30% (IEC34 standard)
Torque limiter	Electrical
Number of starts / hour <sup>1)</sup>	100
Drive nut	Star
Removable adaptation plates (ISO5211)	F03/F05 & F04 (ER 20)   F05/F07 (ER 35 & 60 & 100)
Number of limit switches	4 adjustable switches (5A max.)
Secured manual override	Decutching system and external shaft
Mechanical travel stops	90°
Electric connection	1 Connector 3P+T DIN43650 + 1 ISO M20 (3-position actuators : 2 ISO M20)
Temperature	-10°C to +55°C
Enclosure	IP65
Weight	1Kg to 2,1Kg
Warranty <sup>2)</sup>	3-year warranty or 50 000 actuations

<sup>1)</sup> Recommended use, see instructions notice.

<sup>2)</sup> Tested on testing bench in the worst conditions (maximal torque and duty rating).

### Options

Card with two extra limit switches (EFC.2)
100 / 1000 / 5000 / 10000 Ohms feedback potentiometer (EPR.B) <sup>3)</sup>
0-10V, 0-20mA or 4-20mA transmitter (EPT.C) <sup>4)</sup>
1 or 2 connector M12 3P+T (ECM.1 or ECM.2)
2ème connector 3P+T DIN43650 (ECD.1A)
Handle for manual override (EPR)

<sup>3)</sup> Specify the model.

<sup>4)</sup> Only for an operating time higher or equal to 10s.



Please consider 1.5 safety factor when sizing the actuator

Code	Star drive nut Connection <sup>1)</sup>	Torque	Voltage supplies	Power	Operating time	
					Without load	With load
ER20.X0A.M00 <sup>2)</sup>	14 / F03-F04-F05	20Nm	100V to 240V 50/60Hz (100V to 350V DC)	15W	9s	13s
ER20.X03.M00 <sup>2)</sup>	14 / F03-F04-F05	20Nm	15V to 30V 50/60Hz (12V to 48V DC)	15W	7s	12s
ER35.90A.M00	22 / F05-F07	35Nm	100V to 240V 50/60Hz (100V to 350V DC)	45W	7s	8s
ER35.903.M00	22 / F05-F07	35Nm	15V to 30V 50/60Hz (12V to 48V DC)	45W	6s	7s
ER60.90A.M00	22 / F05-F07	60Nm	100V to 240V 50/60Hz (100V to 350V DC)	45W	14s	15s
ER60.903.M00	22 / F05-F07	60Nm	15V to 30V 50/60Hz (12V to 48V DC)	45W	10s	13s
ER100.90A.M00	22 / F05-F07	100Nm	100V to 240V 50/60Hz (100V to 350V DC)	45W	22s	25s
ER100.903.M00	22 / F05-F07	100Nm	15V to 30V 50/60Hz (12V to 48V DC)	45W	18s	22s

<sup>1)</sup> Reducing sleeves star 14 to square 9-11 or star 22 to square 17.  
<sup>2)</sup> X=removable plate F03/F05 or F04, can be ordered mounted.

## Dimensions

Type : ER20

Type : ER35 & 60 & 100

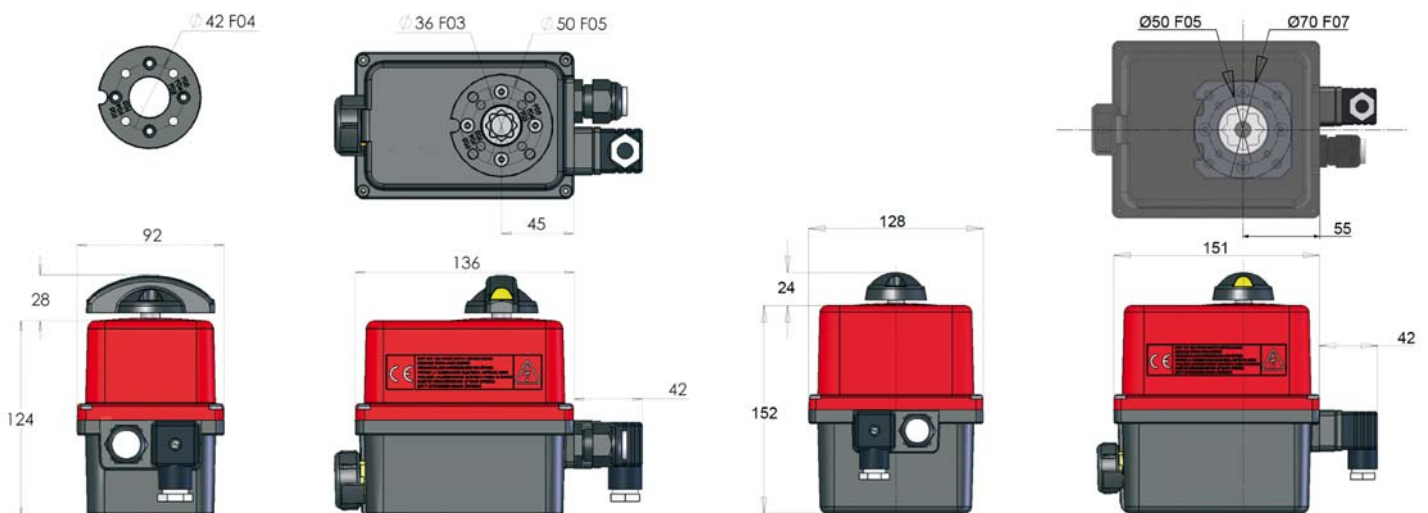

Please consider 1.5 safety factor when sizing the actuator

# Electric wiring

Rep.	Designation	Rep.	Designation
FC0	Open limit switch	FC1	Auxiliary limit switch 1
FCF	Close limit switch	FC2	Auxiliary limit switch 2



The terminal temperature can reach 90°C

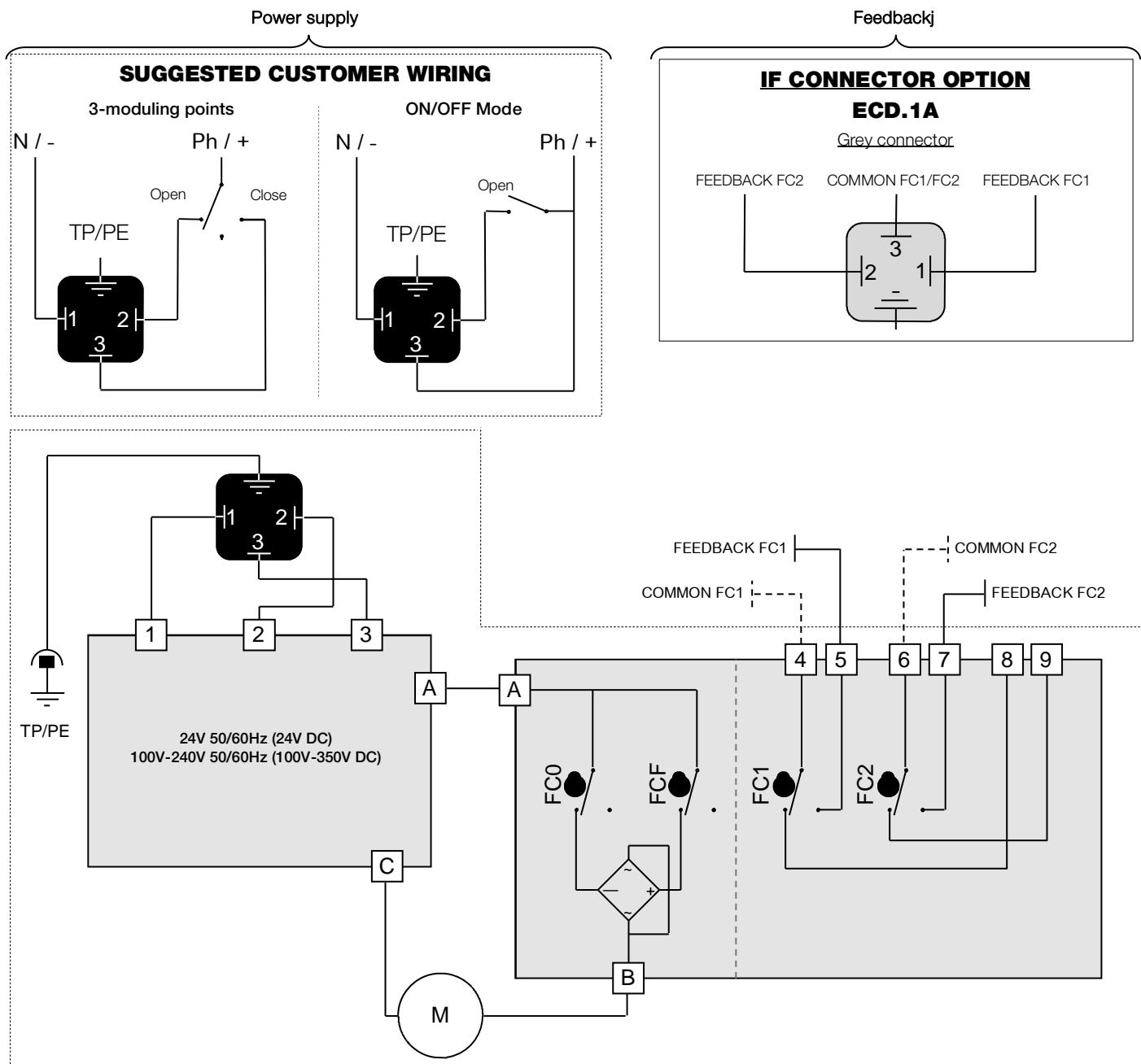

Valpes reserves the right to change or remove products or services from its range at any time and without prior notification or obligation. Valpes does not assume any liability for consequences resulting from the use of this document. There is no guarantee that the information provided here is complete, accurate or up to date.

**ARA**<sup>®</sup>  
PNEUMATIK  
ul. Wyścigowa 38, 53-012 Wrocław  
tel. 71 364 72 82, ara@arapneumatik.pl  
www.arapneumatik.pl



**valpes**  
A WATTS Brand

Z.I. Cent'ralp • 89 rue des étangs • 38430 Moirans France  
Tél. +33 (0) 4 76 35 06 06 • Fax +33 (0) 4 76 35 14 34  
Valpes-info@wattswater.com • www.valpes.com