

aerospace  
climate control  
**electromechanical**  
filtration  
fluid & gas handling  
hydraulics  
pneumatics  
process control  
sealing & shielding

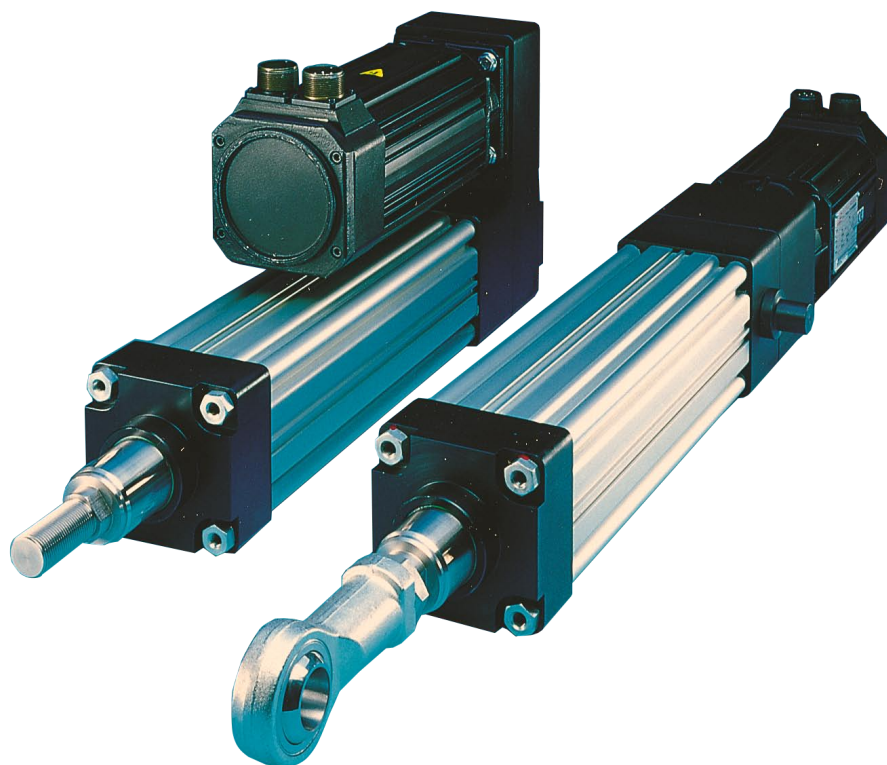

## ET - electro-thrust cylinder

Motion, positioning, material feed and setting

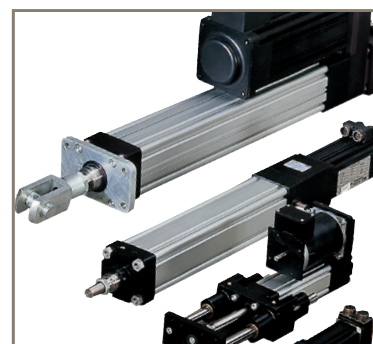

ENGINEERING YOUR SUCCESS.

Autoryzowany dystrybutor Parker:

**ARA**  
PNEUMATIK

53-012 Wrocław tel. 71 364 72 82  
ul. Wyścigowa 38 fax 71 364 72 83

[www.arapneumatik.pl](http://www.arapneumatik.pl)



# The ET Electro Thrust Cylinder

<b>Contents</b>	<b>The ET Electro Thrust Cylinder .....</b>	<b>2</b>
	<b>Product description .....</b>	<b>3</b>
	<b>Product design .....</b>	<b>4</b>
	IP65 rating.....	5
	Special designs .....	5
	<b>Technical Data.....</b>	<b>6</b>
	Permissible side loads.....	8
	Thrust force factor and breakaway torque .....	10
	Transmissible torques in parallel drive mounting .....	11
	Nominal lifetime .....	12
	Relubrication.....	14
	Dimensions.....	15
	Possible motor mounting options.....	17
	<b>Accessories.....</b>	<b>18</b>
	Configuration of the thrust rod .....	18
	Mounting options .....	20
	Initiators / limit switches.....	25
	<b>Order code.....</b>	<b>26</b>

## The ET electro-thrust cylinder: Motion, positioning, material feed and setting

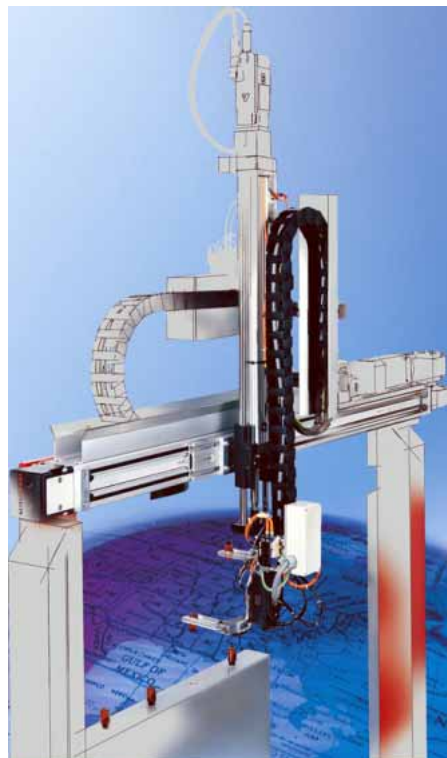

# Product description

## Typical fields of application:

The electro thrust cylinder closes the gap between pneumatic and hydraulic drives. Together with the wide choice of accessories, it offers many possibilities in the field of:

- ⇒ **Material handling and feed systems,**
  - ◆ wood and plastic working industry
  - ◆ vertical actuators for loading machine tools
  - ◆ in the textile industry for tensioning / gripping textile fabrics
  - ◆ in the automotive industry for transporting and feeding components
- ⇒ **Testing equipment and laboratory applications**
- ⇒ **Valve and flap actuation**

## Performance / Technical data:

For precise motion, positioning, setting and actuating, the ET offers:

- ◆ High mechanical efficiency up to 90%
- ◆ Stroke up to 2400mm
- ◆ High traction/thrust force up to 44500N
- ◆ Repeatability  $\pm 0.07\text{mm}$  (up to  $\pm 0.01\text{mm}$ )
- ◆ Speeds up to 1.3m/s
- ◆ Timing belt drive (with parallel motor mounting) also available with transmission ratios
- ◆ Screw pitch from 5 to 50mm/rev
- ◆ 5 different sizes + ETV32 and ETV100 (V=longer service life)
- ◆ Available with servo or stepper motor drive
- ◆ IP54 Standard (Option IP65)

## The technology:

- ⇒ **Advantages of the ballscrew drive**
  - ◆ Smooth operation
  - ◆ Low wear
  - ◆ Low maintenance
  - ◆ High efficiency
  - ◆ long life
  - ◆ High precision even at low speed, as hardly any stick-slip effect occurs
  - ◆ High speeds are possible due to high efficiency and low heat generation



Direct drive



Parallel drive

# Product design

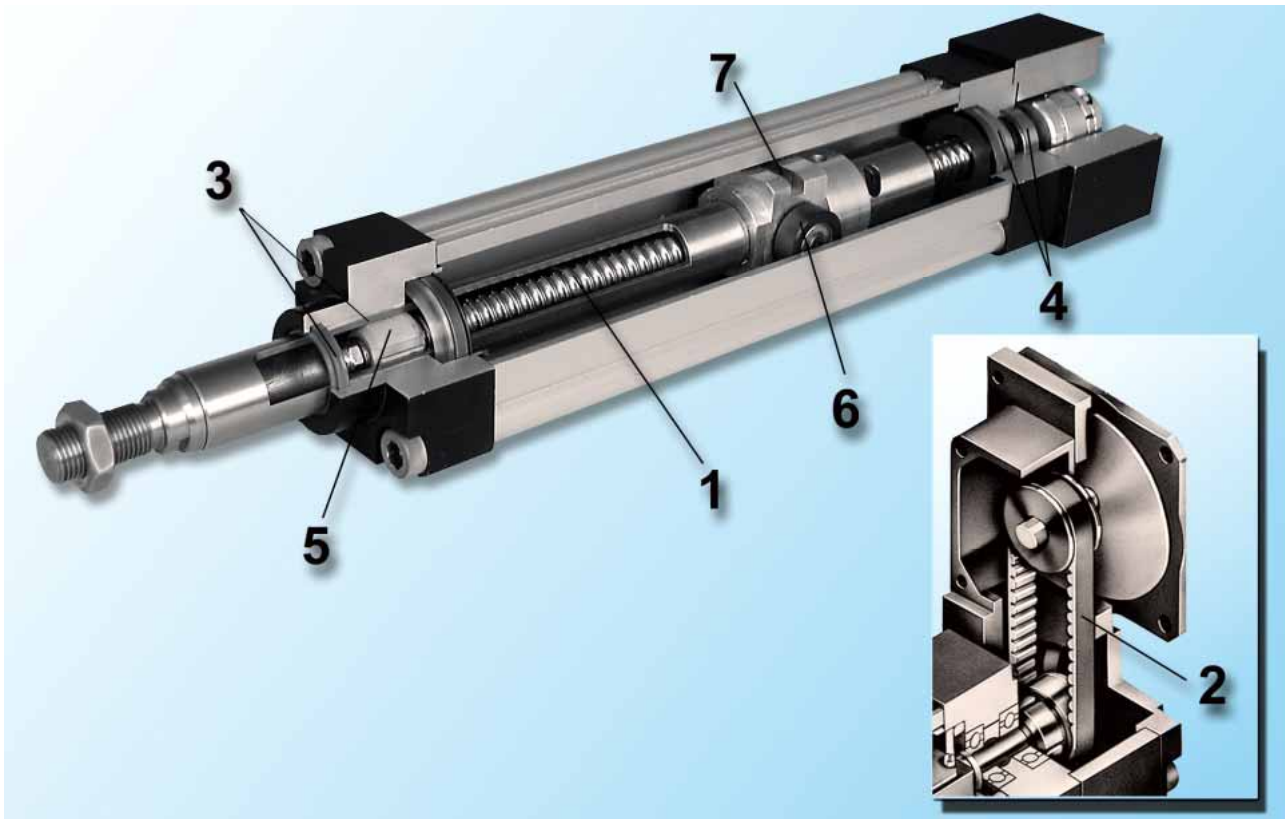

## (1) Ballscrew:

- ⇒ As a feed unit, a high-quality precision class C7 ballscrew is used.
- ⇒ The balls between spindle and nut ensure a low frictional resistance. This ensures an especially smooth operation over the entire speed range, high lifetime and an excellent efficiency. Smallest travels are possible due to a low stick-slip effect.

## (2) Timing belt transmission:

- ⇒ The slip- and maintenance free timing belt transmission (only with parallel drive) has an excellent efficiency.
- ⇒ The transmission ratios 1:1, 1:1.5, 1.5:1 and 2:1 are available.

## (3) Linear sliding bearing:

- ⇒ The extra long cylinder rod bearing allows high side load forces. A wiper ring prevents the ingress of external contamination under normal conditions. In the event of fine dust, a high amount of dirt as well as muds and liquids, special sealing is required, which is available on request.

## (4) rear screw bearing:

- ⇒ The screw bearing on the drive side accepts high axial and radial forces. It consists of two interlinked angular contact ball bearings which accept the thrust and traction forces of the cylinder.

## (5) Front screw bearing:

- ⇒ The front screw support bearing is supported by a polymer sliding bearing. This eliminates vibrations and run-out. This increases the precision, dynamic behaviour and lifetime of the screw.

## (6) Anti-rotation device

- ⇒ The integrated anti-rotate mechanism, with three Nylatron NS wheels prevents the rod-rotation and can absorb minor torsional movements.

## (7) Permanent magnet

- ⇒ All electro thrust cylinders are equipped with a permanent magnet integrated into the screw nut. The permanent magnet actuates the sensors, which can be mounted in the longitudinal grooves of the cylinder body.

## IP65 rating

The IP65 version is intended for the use under difficult environmental conditions, if the drives must be cleaned with liquids or for use in dusty or wet environments. Depending on the medium, the sealing system might need adaptation. It is therefore necessary, to contact us to discuss the application.



- ⇒ **Available for the sizes ET\_32, 50, 80 and 100.**
- ⇒ **Polyester/polyurethane cylinder body**
- ⇒ **Special dual piston rod seal**
- ⇒ **All external fixings in corrosion-resistant materials**
- ⇒ **Accessories are available in corrosion resistant steel as an option.**
- ⇒ **Use of the standard position sensors**

## Special designs

The following special features are available on request:



- ⇒ **blow valve**
- ⇒ **Oil splash lubrication of the screw for high-duty applications**
- ⇒ **Customized mountings and rod ends**
- ⇒ **Mounting of customer motors**
- ⇒ **Preparation of the cylinder for use under aggressive environmental conditions**
- ⇒ **Overlong thrust rod**
- ⇒ **Polished thrust rod**
- ⇒ **Thrust rod hard-chrome plated**
- ⇒ **.....**

# Technical Data

Cylinder size	Unit	ET_32		ETV32		ET_50			ET_80		
Type		M05	M10	M05	M10	M05	M10	M16	M05	M10	M25
<b>Screw</b>											
Screw pitch	mm	5	10	5	10	5	10	16	5	10	25
Screw diameter	mm	12		12		16			25		
<b>Travels, speeds and accelerations <sup>1</sup></b>											
Available strokes	mm	continuous, from 50-750		continuous, from 50-750		continuous, from 50-1000			continuous, from 100-1500		
Max. permissible speeds at a stroke =											
50-300mm	mm/s	420	840	420	840	320	730	1170	270	540	1340
450mm	mm/s	420	840	420	840	320	730	1170	270	540	1340
600mm	mm/s	270	540	270	540	320	630	1000	270	540	1340
750mm	mm/s	190	380	190	380	230	450	720	270	540	1340
1000mm	mm/s	-	-	-	-	150	300	470	210	420	1040
1250mm	mm/s	-	-	-	-	-	-	-	150	290	720
1500mm	mm/s	-	-	-	-	-	-	-	110	210	530
Max. acceleration	m/s <sup>2</sup>	3	6	3	6	3	6	10	3	6	10
<b>Forces <sup>2</sup></b>											
Max. traction/thrust force	N	600		600		3300			8300		
<b>Weight and mass moments of inertia</b>											
Weight of base unit with zero stroke	kg	1.3		1.2		2.3			6.8		
Weight of additional length	kg/m	3		3		6			10		
Mass moment of inertia $J_0$ refers to the drive shaft without stroke for $i=1$ , for $i \neq 1$ applies: $J_{total} = [J_0(i=1) + J_H(i=1)] / i^2$											
Parallel drive	kgmm <sup>2</sup>	4.2	4.4	3.8	4.1	55.4	57.6	60.5	128.9	135.3	142.8
Direct drive	kgmm <sup>2</sup>	2.5	2.7	2.4	2.5	12.9	15.8	18.7	74.8	81.1	88.7
Mass moment of inertia $J_H$ refers to the drive shaft per meter of additional length for $i=1$ ;											
Drive parallel/direct	kgmm <sup>2</sup> /m	16.6	18.5	16.6	18.5	51.6	54.0	56.8	302.0	306.0	332.0
<b>Precision and backlash</b>											
Repeatability	mm	± 0.07									
Backlash	mm	0.02 with inline drive/0.025 with parallel and reverse drive									
<b>Efficiency</b>											
Direct drive	%	90									
Parallel drive	%	81									
<b>ratios</b>											
ratios		1:1 (inline or parallel drive); 1.5:1 (parallel drive-transmission to slow); 2:1 (parallel drive-transmission to slow); 1:1.5 (parallel drive – transmission to fast only with ET_032)									

<sup>1</sup> Please contact us if you wish to work at higher speeds or at operation times >80%!

<sup>2</sup> Values refer to the maximum permissible cylinder load. Please do also respect the "life time curve"! With parallel drive, the maximum thrust/traction force is limited by the timing belt, see "transmissible torques at parallel drive"

**ET\_32, ETV32, ET\_50, ET\_80 available for servo motor or stepper motor mounting**



Cylinder size	Unit	ETB100				ETV100		ETB125			
Type		M05	M10	M20	M40	M05	M10	M05	M10	M20	M50
<b>Screw</b>											
Screw pitch	mm	5	10	20	40	5	10	5	10	20	40
Screw diameter	mm	40				40		50			
<b>Travels, speeds and accelerations <sup>1</sup></b>											
Available strokes	mm	continuous,from 100-1500					continuous,from 100-2400				
Max. permissible speed at stroke =											
50-300mm	mm/s	170	340	670	1340	170	340	140	270	540	1340
450mm	mm/s	170	340	670	1340	170	340	140	270	540	1340
600mm	mm/s	170	340	670	1340	170	340	140	270	540	1340
750mm	mm/s	170	340	670	1340	170	340	140	270	540	1340
1000mm	mm/s	170	340	670	1340	170	340	140	270	540	1340
1250mm	mm/s	170	340	670	1340	170	340	140	270	540	1340
1500mm	mm/s	160	310	610	1220	160	310	140	270	540	1340
1600mm	mm/s	-	-	-	-	-	-	140	270	540	1340
1800mm	mm/s	-	-	-	-	-	-	140	270	530	1330
2000mm	mm/s	-	-	-	-	-	-	120	230	450	1100
2200mm	mm/s	-	-	-	-	-	-	100	190	380	950
2400mm	mm/s	-	-	-	-	-	-	90	170	330	820
Max. acceleration	m/s <sup>2</sup>	3	6	6	10	-	-	3	36	6	10
<b>Forces <sup>2</sup></b>											
Max. traction/thrust force	N	21200				21200		44500			
<b>Weight and mass moments of inertia</b>											
Weight of base unit with zero stroke	kg	14.8				16.6		30			
Weight of additional length	kg/m	20				20		37			
Mass moment of inertia $J_0$ refers to the drive shaft without stroke for $i=1$ , for $i \neq 1$ applies: $J_{total}=[J_0(i=1)+J_H(i=1)] / i^2$											
Parallel drive	kgmm <sup>2</sup>	708.3	749.2	818.3	918.9	866.9	947.9	3470.1	3484.7	3543.2	3952.7
Direct drive	kgmm <sup>2</sup>	401.8	442.7	517.7	612.4	442.1	523.1	3364.4	3379.0	3437.5	3847.1
Mass moment of inertia $J_H$ refers to the drive shaft per meter of additional length for $i=1$											
Drive parallel/direct	kgmm <sup>2</sup> /m	1978.0	1986.0	2016.4	2138.0	1978.0	1986.0	4821.6	4836.4	4895.7	5312.0
<b>Precision and backlash</b>											
Repeatability	mm	± 0.07									
Backlash	mm	0.02 with inline drive/0.025 with parallel and reverse drive									
<b>Efficiency</b>											
Direct drive	%	90									
Parallel drive	%	81									
<b>ratios</b>											
ratios		1:1 (inline or parallel drive); 1.5:1 (parallel drive-transmission to slow); 2:1 (parallel drive-transmission to slow)									

<sup>1</sup> Please contact us if you wish to work at higher speeds or at operation times >80%!

<sup>2</sup> Values refer to the maximum permissible cylinder load. Please do also respect the "life time curve"! With parallel drive, the maximum thrust/traction force is limited by the timing belt, see "transmissible torques at parallel drive"

***ET\_100, ETV100, ET\_125 available for operation with servo motor drive***

***Technical data with safety factor S=1 taken into consideration. Temperature range from 0°C to +60°C. Max. permissible air humidity: 90% - the dew point may not be reached at the cylinder! The technical data apply under normal conditions and only for the individual operating and load mode. In the case of compound loads, it is necessary to verify in accordance with normal physical laws and technical standards whether individual ratings should be reduced. In case of doubt please contact Parker Hannifin.***

## Permissible side loads

The electro thrust cylinder disposes of a generously dimensioned cylinder rod bearing together with 3 Nylatron NS wheels which prevent the rod rotation. Thanks to this system, the cylinder is able to accept a certain side load.

Please note that the load bearing capacity increases with a longer stroke, as the distance between the bearings becomes longer. In order to reach the required load values in a given application, it can be useful to select a cylinder with a longer stroke than necessary for the application.

**Example:**

An ET\_50 with 200mm stroke can bear a lateral force of 72N in fully extended state.

An ET\_50 with 300mm stroke can however, if only 200mm are extended, accept a lateral force of 166N.

If your application requires an even higher load bearing capacity, you can fortify the cylinder with the **rod guiding system** (see page 20) available as an option (not for ETB125).

### Lateral load – profile orientation

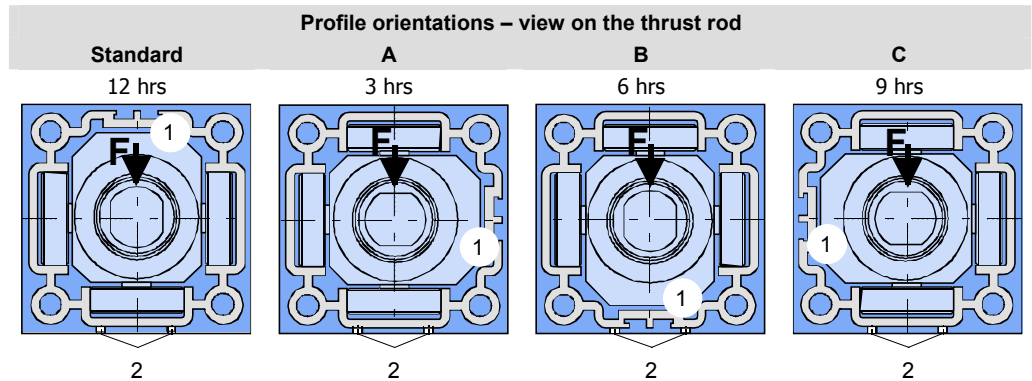

1: Sensor mounting grooves: on ET\_32, 50 and 80 only on one side, on ET\_100 and ETB125 on all sides.

2: Thread for foot mounting

F: Lateral force

- ◆ with standard and B profile orientation the lateral force is accepted by two rollers, with A and C profile orientation, only by a single roller.
- ◆ If the lateral force F does not apply, as in the drawing, from above or below but from the right or the left, the opposite of the above description applies!



**The profile orientation of ET\_32, 50 and 80 does also determine the mounting position of the sensors and does therefore also influence the mounting position of the motor. At the same time, the profile orientation defines the position of the lubrication bore.**



**Lateral forces may reduce the lifetime of the cylinder. If you want to exploit the maximum possible lateral force at 100%, you will have to reduce the duty cycle to 40% or you can only exploit 40% of the max. possible lateral force if you want to operate at a 100% duty cycle.**





*The curves given here are only valid for a profile orientation of 12 hrs (standard) and 6 hrs (B), if the lateral force applies from above or from below. With profile orientation 3 hrs and 9 hrs (A and C), the permissible lateral load is halved!*

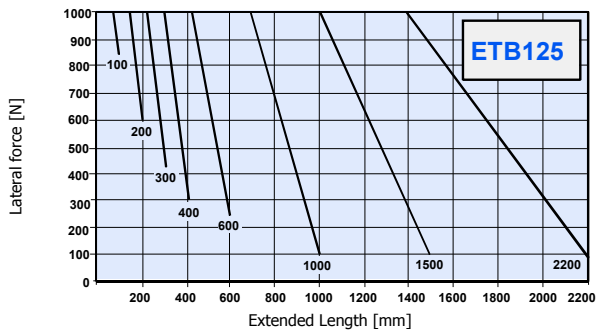
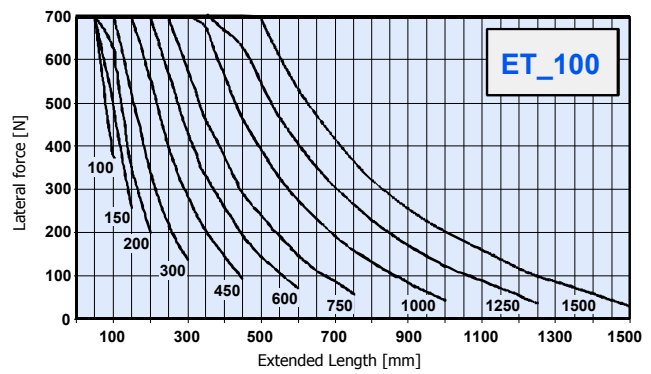
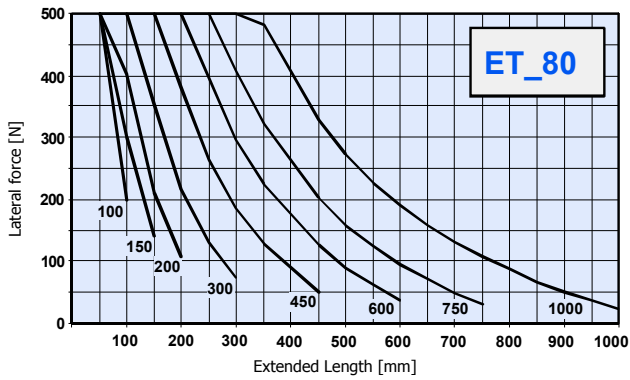
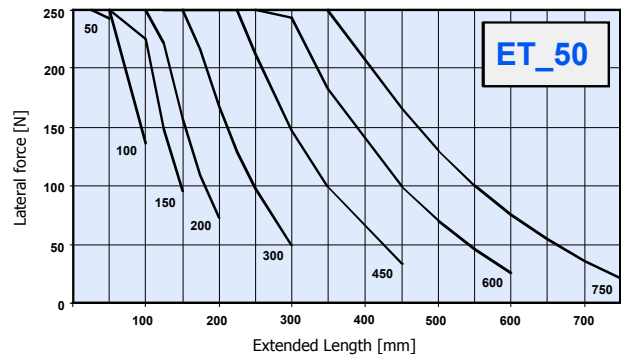
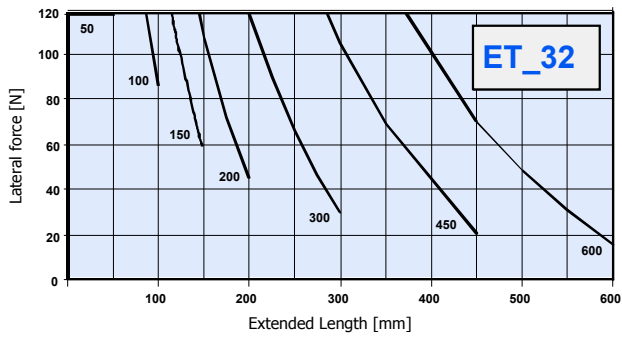

## Thrust force factor and breakaway torque

**The following table shows the resulting thrust or traction per 1Nm of torque at the screw, taking the efficiency, belt transmission ratio and screw pitch into consideration. The table can be used for a rough calculation of the drive dimensioning. For precise drive dimensioning, the mass moment of inertia of the screw must be taken into consideration! Please do also account for transmittable torques in parallel drives (see page 11) and other limit values**

**The** "L" or "P" stands for the motor mounting L = direct (in-line), P = all parallel or reverse motor positions; "A" stands for a ratio of  $i = 1:1$ , "B" for  $i = 1.5:1$ , "D" for  $i = 2:1$ , "Z" for  $i = 1:1.5$ .

Example: ET\_32 (size) M04 (screw pitch) L (motor mounting) A (ratio)

	Thrust force factor [N/Nm]	Breakaway torque for the drive [Nm]
<b>ET_32</b>		
ET_32-M05LA	1130	0.2
ET_32-M05PA	1015	0.2
ET_32-M05PZ	675	0.4
ET_32-M10LA	565	0.3
ET_32-M10PA	510	0.3
ET_32-M10PZ	335	0.4
<b>ET_50</b>		
ET_50-M05LA	1130	0.4
ET_50-M05PA	1015	0.4
ET_50-M05PB	1525	0.3
ET_50-M05PD	2035	0.2
ET_50-M10LA	565	0.5
ET_50-M10PA	510	0.6
ET_50-M10PB	765	0.4
ET_50-M10PD	1015	0.3
ET_50-M16LA	353	0.5
ET_50-M16PA	317	0.6
ET_50-M16PB	476	0.4
ET_50-M16PD	635	0.3
<b>ET_80</b>		
ET_80-M05LA	1130	0.5
ET_80-M05PA	1015	0.6
ET_80-M05PB	1525	0.4
ET_80-M05PD	2035	0.3
ET_80-M10LA	565	0.6
ET_80-M10PA	510	0.7
ET_80-M10PB	765	0.4
ET_80-M10PD	1015	0.3
ET_80-M25LA	225	0.9
ET_80-M25PA	205	1.0
ET_80-M25PB	305	0.7
ET_80-M25PD	405	0.5
<b>ET_100</b>		
ET_100-M05LA	1130	0.5
ET_100-M05PA	1015	0.6
ET_100-M10LA	565	0.6
ET_100-M10PA	510	0.7
ETB100-M20LA	283	0.7
ETB100-M20PA	255	0.8
ETB100-M40LA	140	0.9
ETB100-M40PA	125	1.0
<b>ETB125</b>		
ETB125-M05LA	1130	2.6
ETB125-M05PA	1107	2.9
ETB125-M10LA	565	3.0
ETB125-M10PA	508	3.3
ETB125-M20LA	283	3.4
ETB125-M20PA	255	3.8
ETB125-M50LA	113	3.8
ETB125-M50PA	102	4.2

# Transmissible torques in parallel drive mounting

The table shows the torques that can be transmitted by the timing belt.  
Please respect in addition the maximum permissible traction/thrust force:

**ET\_32, 50, 80** (see page 6), **ET\_100, ETB125** (see page 7).

For the conversion, you can use the **thrust force factor table** (see page 10).

**The** "L" or "P" stands for the motor mounting L = direct (in-line), P = all parallel or reverse motor positions; "A" stands for a ratio of  $i = 1:1$ , "B" for  $i = 1.5:1$ , "D" for  $i = 2:1$ , "Z" for  $i = 1:1.5$ .

	Motor / gear type																	transmissible motor torque [Nm]									
	Stepper motor Motor code			Servo motor Motor code											Gear code				Speed at the drive shaft [rpm]								
	20	30	40	37	47	57	67	77	87	J4	J5	J6	J7	P3	P4	P5	P7	N6	N8	100	500	1000	1500	2000	2500	3000	3300
<b>ET_32</b>	PA	X				X														1.68	1.35	1.09	0.92	0.84	0.75	0.68	0.65
	PZ	X				X														1.22	0.99	0.82	0.72	0.63	0.57	0.53	0.50
<b>ET_50</b>	PA	X			X															2.80	2.19	1.73	1.42	1.27	1.12	1.01	0.99
	PB	X																		1.93	1.55	1.25	1.04	0.94	0.84	0.76	0.73
	PD	X																		1.43	1.16	0.94	0.80	0.73	0.66	0.60	0.57
	PA		X				X	X										x		3.64	2.93	2.39	2.10	1.85	1.67	1.53	1.38
	PB		X																	2.40	1.96	1.62	1.44	1.28	1.17	1.08	0.99
<b>ET_80</b>	PA		X																	7.07	5.55	4.39	3.77	3.22	2.84	2.52	2.20
	PB		X																	5.08	4.04	3.25	2.83	2.46	2.21	2.00	1.78
	PD		X																	3.64	2.93	2.39	2.10	1.85	1.67	1.53	1.38
	PA			X	X		X	X		X				x				x	x	13.4	10.6	8.43	7.16	6.11	5.40	4.79	4.18
	PB			X	X		X	X					x					x		9.66	7.69	6.18	5.38	4.68	4.19	3.79	3.38
	PD			X			X											x		6.91	5.57	4.54	4.01	3.51	3.18	2.91	2.65
<b>ET_100</b>	PA							X	X		X	X		x	x			x	61.2	37.1	32.6	30.4	28.5	27.6	25.9	24.8	
<b>ETB125</b>	PA							X			X	X			x	x			91.0	81.0	77.0	72.0	71.0	--	--	--	

Motor / gear codes: **Order code** (see page 26)

# Nominal lifetime

## Nominal lifetime of ballscrew and rear screw bearing

The lifetime depends strongly on the degree of power exploitation and on impermissible operating states occurring – even if only for a short time -. The lifetime of the stripper depends strongly on the frequency and speed of motion, especially in connection with lateral forces (danger of heating) as well as the amount of contamination.

### Prerequisite:

- ⇒ **Bearing and screw temperature between 20°C and 40°C**
- ⇒ **no affection of the lubricant, for example by external particles**
- ⇒ **lubrication conform to the specifications**
- ⇒ **the given values for thrust force, speed and acceleration must be adhered to at any rate.**
- ⇒ **no contact to mechanical end stops (external or internal) and no other abrupt loads**
- ⇒ **no lateral forces are being applied to the cylinder rod**
- ⇒ **no short stroke (stroke smaller than 2.5 x screw pitch)**
- ⇒ **no vibration at standstill or at very low speed**
- ⇒ **no high exploitation of several power features at a time (for example maximum speed or thrust force)**

*only under these circumstances, the service life corresponds to the nominal lifetime*

## Determination of the medium dynamic axial load:

If the load on the ballscrew is varying, the lifetime must be determined with the aid of the medium dynamic axial load. The medium dynamic axial load is determined as follows in the event of cascaded load changes:

$$F_m = \sqrt[3]{\frac{1}{L} * (Fa_1^3 * s_1 + Fa_2^3 * s_2 + \dots + Fa_n^3 * s_n)}$$

$F_m$  = medium dynamic axial load [N]  
 $F_{an}^*$  = varying load [N]  
 $s_n^*$  = travel under a defined load  $F_n$  [mm]  
 $L^*$  = total travel [mm]

*\* Forces and travels must be entered as absolute values.*

If you need the lifetime as the number of possible cycles, just divide the lifetime in kilometers by twice the stroke traveled.

## The application factor fw

The application factor has a strong influence on the lifetime of a screw. The application factor can be roughly determined with the aid of the following table:

Load from vibration, shock, temperature, dirt	Screw speed	fw
light	n < 500 rpm	1.0 - 1.5
Medium	500 < n < 2000 rpm	1.5 - 2.0
high	2000 < n < 3300 rpm	2.0 - 3.5

## Lifetime calculation:

$$Ln(fw) = \frac{Ln(fw=1.0)}{fw^3}$$

Ln: Nominal lifetime  
 Ln(fw=1.0): see lifetime diagrams  
 fw: application factor

## Lifetime diagrams

The screw lifetime is calculated with the factor  $f_w=1.0$ .

Lifetime of an ET\_32 screw and fixed bearing

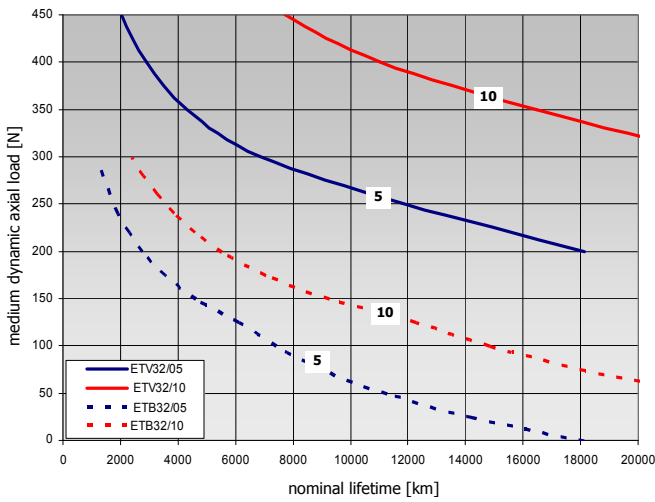

Lifetime of an ET\_50 screw and fixed bearing

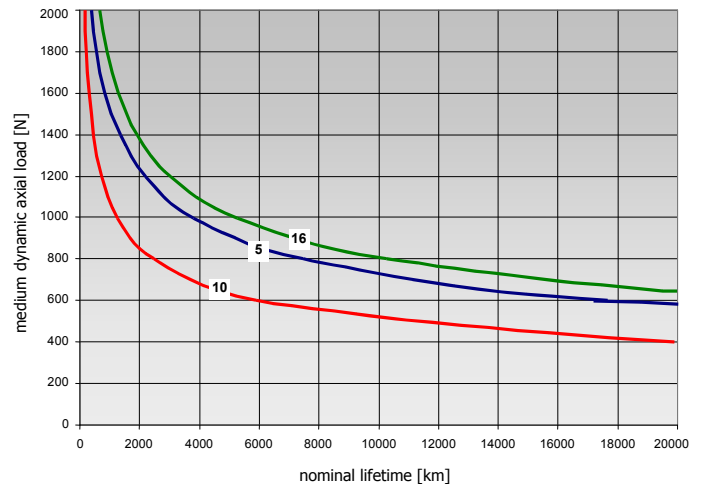

Lifetime of an ET\_80 Screw and fixed bearing

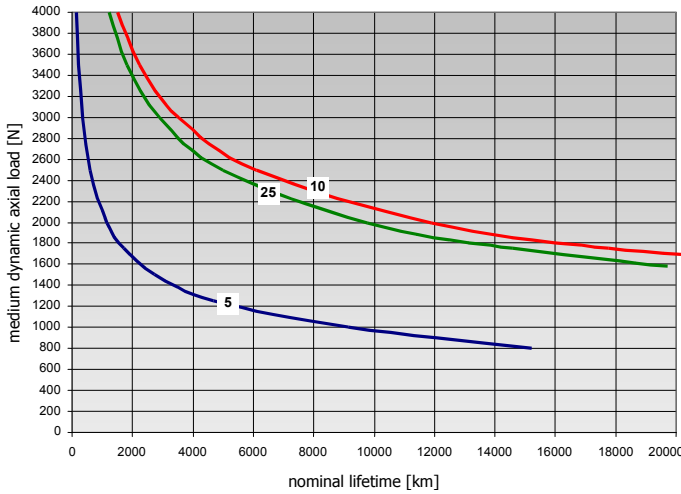

Lifetime of an ETB100 Screw and fixed bearing

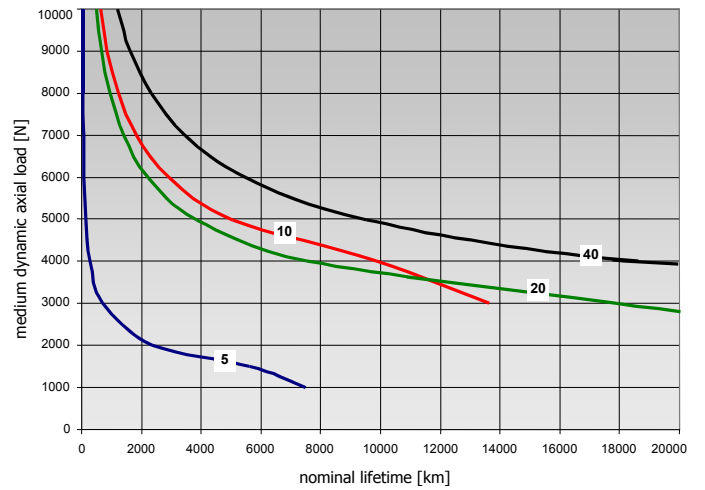

Lifetime of an ETV100 Screw and fixed bearing

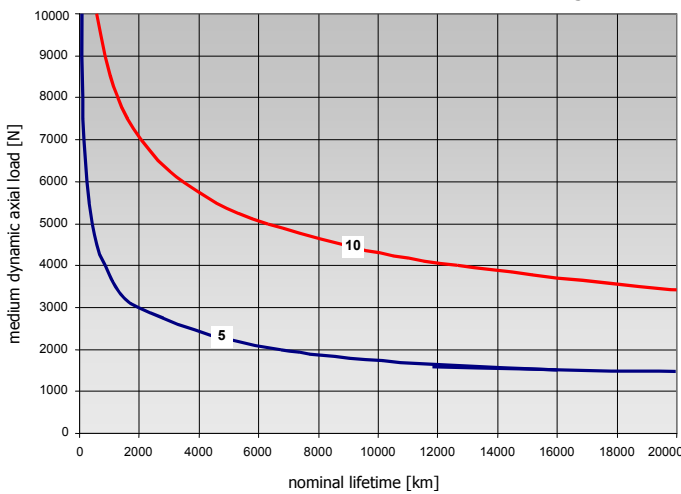

Lifetime of an ETB125 Screw and fixed bearing

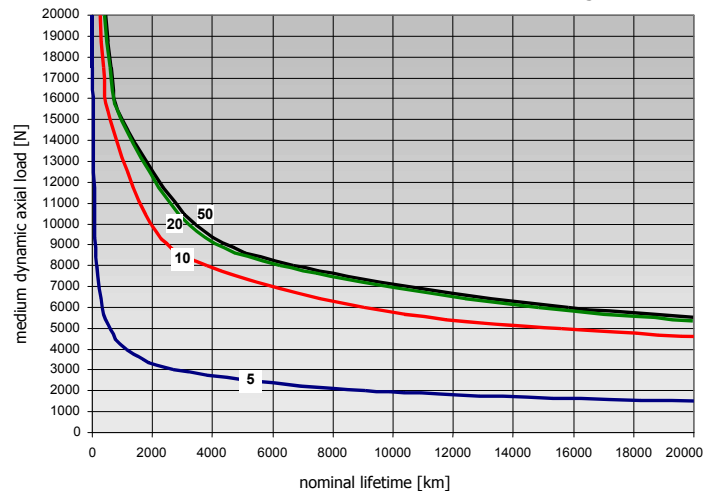

Designation: 5 = 5mm, 10 = 10mm screw pitch etc.

# Relubrication

## Lubrication interval for the ballscrew drive

All sizes have a lubrication bore in the cylinder body (in the middle of the aluminium profile), which permits to lubricate the screw nut.  
 On the ET\_32, 50 and 80 cylinders, this bore can be found at the same side as the sensor mounting grooves. Free access to this bore – even after integration of the cylinder into a system – can be ensured by choosing the corresponding **profile orientation** (see page 8).  
 The necessary lubrication intervals depend on the application.

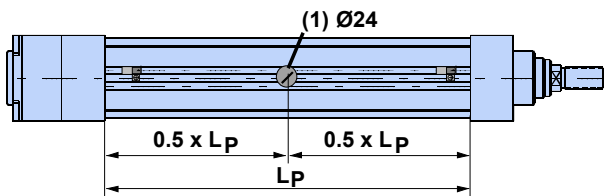

(1): Lubrication bore  
 Lp: Length of profile

### Greatest interval with an application factor of $f_w = 1.0$ :

⇒ **12 months or 350km, depending on which value is first reached.**

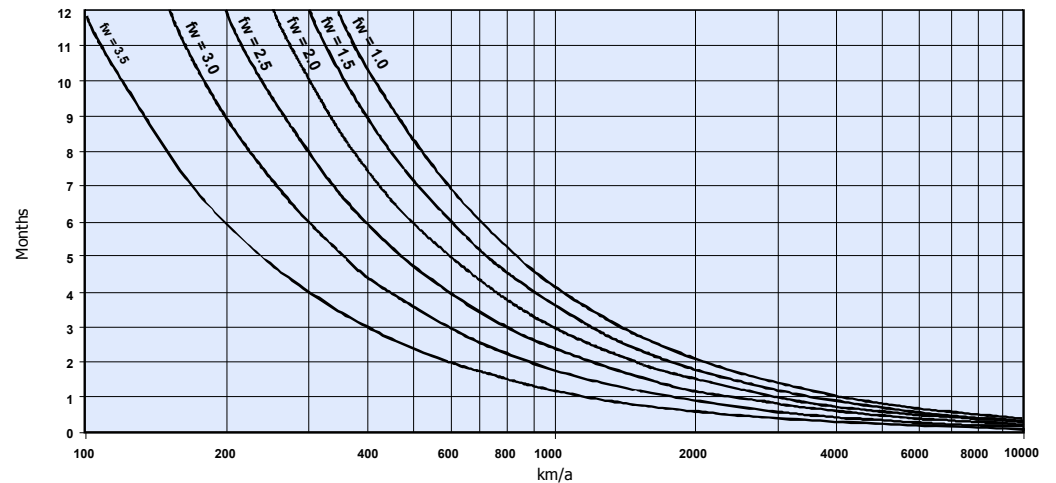

## Lubrication intervals for the screw bearing

### The lubrication interval is half the grease service life:

ETV100 - M05 (increased service life)	Lubrication after approx. 4000km
ETV100 - M10 (increased service life)	Lubrication after approx. 7000km
ETB125 - M05	Lubrication after approx. 2000km
ETB125 - M10	Lubrication after approx. 3000km
ETB125 - M20	Lubrication after approx. 6000km
ETB125 - M50	-no lubrication necessary up to 20000km
ET_32 to ETB100 are not lubricated at the screw support bearing.	

# Dimensions

## Electro thrust cylinder – in-line motor mounting

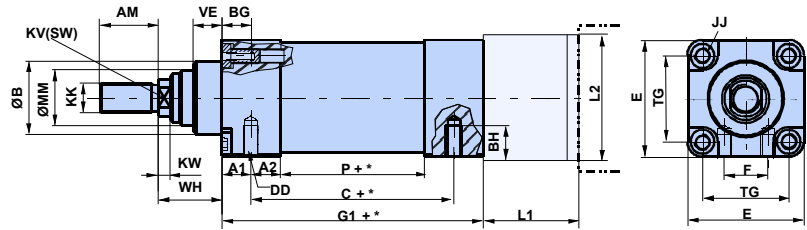

## Electro thrust cylinder – parallel motor mounting

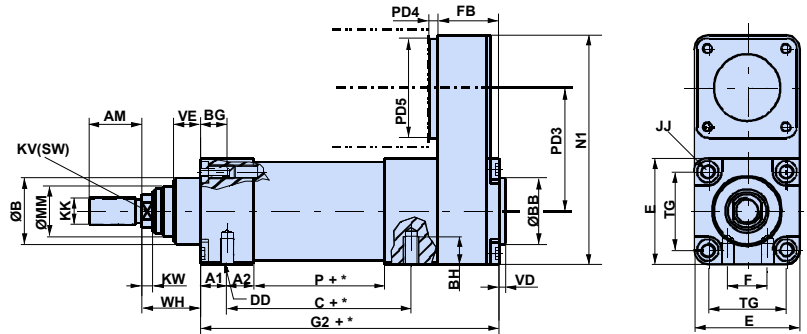

Stated in mm

## ET (inline/parallel)

	A1	A2	AM	BG	BH	DD	E	F	JJ**	KK	KV	ØMM	TG	KW	N1	FB	VD	ØBB
ET_32	14	14	22	14,5	9	M6x1.0 (1)	46.5	16	M6x1.0	M10x1.2 5	10	18	32.5	5	106.4	37	4	30
ET_50	16	16	32	16	12.7	M8x1.25	63,5	24	M8x1.25	M16x1.5	17	25	46.5	6.5	139.4	39	4	40
ET_80	21	21	40	16	17.5	M10x1.5	95.3	30	M10x1.5	M20x1.5	22	35	72	10	191.3	57	5	45
ET_100	27.5	27.5	54	16	24	M12x1.75	114	50	M10x1.5	M27x2.0	27	50	89	13	254	79	4	55
ETB125	42.4	33	72	16	24	M16x2.0	139.7	64	M12x1.7 5	M36x2.0	41	70	110	13	334.5	127.1	7	60

\*\* Thread "JJ" is not available in IP65 version for ET\_32 and ET\_50!

(1) If you wish to mount a component at the front screws (with thread II = M6x1), please provide for through holes with a diameter of at least 7mm at this component, even though this is not the common norm.

	Standard cylinder			IP65 rating		
	VE	WH	ØB	VE	WH	ØB
ET_32	13	26	30	40	50	46
ET_50	16	37	40	43	64	62
ET_80	20	46	50	55	81	68
ET_100	20	51	65	60	91	89
ETB125	20	68	90	On request		

## Stroke dependent dimensions

		Standard cylinder				IP65 rating			
		C+*	G1+*	G2+*	P+*	C+*	G1+*	G2+*	P+*
ET_32	M05	112.5	140.5	176.7	84.5	115.7	143.7	179.9	84.5
	M10	112.5	140.5	176.7	84.5	115.7	143.7	179.9	84.5
ETV32	M05	100.0	138.0	163.2	66.5	103.2	141.2	166.4	66.5
	M10	102.8	140.8	166.0	69.3	106.0	144.0	169.2	69.3
ET_50	M05	128.4	160.4	199.5	96.4	131.6	163.6	202.7	96.4
	M10	131.4	163.4	202.5	99.4	134.6	166.6	205.7	99.4
ET_80	M16	135.4	167.4	206.5	103.4	138.6	170.6	209.7	103.4
	M05	129.5	173.0	228.3	86	132.7	176.2	231.5	86
ET_80	M10	148.1	191.6	246.9	104.6	151.3	194.8	250.1	104.6
	M25	154.9	198.4	253.7	111.4	158.1	201.6	256.9	111.4
ETB100	M05	201.5	259.7	335.5	132.1	204.7	262.9	338.7	132.1
	M10	221.3	279.5	355.3	151.9	224.5	282.7	358.5	151.9
	M20	239.3	297.5	373.3	169.9	242.5	300.7	376.5	169.9
ETV100	M40	249.4	307.6	383.4	179.9	252.6	310.8	386.6	179.9
	M05	222.3	290.2	366	143.1	225.5	293.4	369.2	143.1
	M10	263.1	331	406.8	183.9	266.3	334.2	410.0	183.9
ET125	M05	207.0	283.9	411.0	140.0	On request			
	M10	237.0	313.9	441.0	170.0				
	M20	237.0	313.9	441.0	170.0				
	M50	260.0	336.9	464.0	193.0				

+\* =Measure + length of desired stroke **Definition of stroke** (see page 16)



## Definition of stroke, travel and safety travel

- Stroke:** The stroke to be indicated in the order code is the maximum possible stroke between the internal end stops.
- Working stroke:** The travel is the distance which you need to move in your application. It is always shorter than the stroke.
- Safety travels S1, S2:** The safety travels are required to slow down the cylinder after it has passed a limit switch (Emergency stop, in order to avoid contact with the mechanical limit stops). For vertical mounting, S1 and S2 must in general be different. The minimum safety travels given in the table are, according to experience, sufficient for most applications. With demanding applications (great masses and high dynamic), the safety travel has to be calculated and enlarged accordingly (dimensioning on demand).

## Minimum safety travels

Cylinder	ET_32		ET_50			ET_80			ET_100				ETB125			
Type	M05	M10	M05	M10	M16	M05	M10	M25	M05	M10	M20	M40	M05	M10	M20	M50
<b>S1 = S2</b>	10	20	10	20	30	10	20	30	10	20	25	30	10	20	25	40

Recommended minimum safety travels with horizontal mounting position: Calculated for a load of up to 50% of the maximum permissible thrust/traction force and for a speed of up to 50% of the maximum permissible speed and under the condition that the drive is able to generate a corresponding braking torque.

Recommended safety travel =  $S1+S2+10mm$

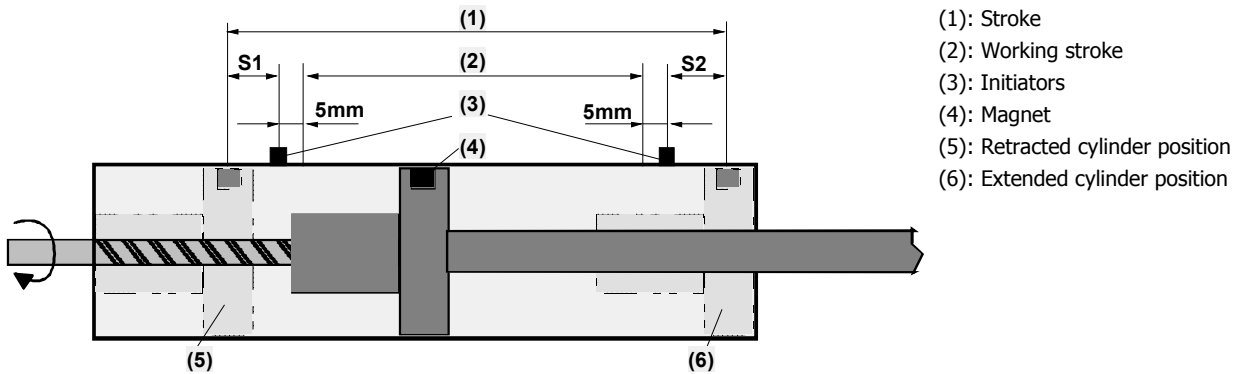

**Help for the order statement:  $Stroke \geq working\ stroke + 10mm + S1 + S2$**

This formula takes a distance between the software end limit and a limit switch of 5mm per side into consideration. The length of this distance depends on the closed loop controller used.

# Possible motor mounting options

## Motor / gear mounting, transmission ratios, dimensions

The "L" or "P" stands for the motor mounting L = direct (in-line), P = all parallel or reverse motor positions; "A" stands for a ratio of  $i = 1:1$ , "B" for  $i = 1.5:1$ , "D" for  $i = 2:1$ , "Z" for  $i = 1:1.5$ .

	prepared for motor / gear mounting	Mounting method/transmission ratio					Order code	Dimensions in [mm]				
		LA	PA	PB	PD	PZ		direct L1	direct L2	parallel PD3(1)	parallel PD4	parallel PD5
ET...	for stepper motor mounting											
S32	NEMA 23 (SY56)	x	x			x	20	44.25	57.15	54.00	5.75	57.15
S50	NEMA 23 (SY56)	x	x	x	x		20	53.50	63.50	75.00	5.75	57.15
	NEMA 34 (SY83)	x	x	x			30	68.25	82.55	82.50	7.75	82.55
S80	NEMA 34 (SY83)	x	x	x	x		30	79.50	95.25	95.00	7.75	86.36
	NEMA 42 (SY107)	x	x	x			40	89.26	107.95	105.00	7.75	107.95
ET...	for servo motor / gear mounting											
B32	NEMA 23 with 9.525mm shaft (i.e. SM23 with long shaft)	x	x			x	20	61.10	57.15	54.00	5.75	57.15
V32	MH56-B5/9 or SMH60-B8/9	x	x			x	47*	49.80	57.15	54.00	5.75	57.15
B50	NEMA 23 with 9.525mm shaft (i.e. SM23 with long shaft)	x	x	x	x		20	66.50	63.50	75.00	5.75	57.15
	NEMA 34 with 1/2 inch shaft	x	x				30	68.25	82.55	82.50	7.75	82.55
	NEMA 34 with 14mm shaft		x				37	68.25	82.55	82.50	7.75	82.55
	MH70-B05/11 or SMH60-B05/11	x	x				57	59.00	69.80	82.50	8.74	76.20
	SMH82-B08/14	x	x				67	65.60	95.25	82.50	8.56	95.25
	P3 (planetary gear)	x					P3	83.00	72.00	--	--	--
	PE3 (planetary gear)	x	x				N6	69.50	90.00	82.5	2.00	72.15
B80	NEMA 34 with 1/2 inch shaft (BE34)	x	x	x	x		30	87.50	95.00	95.00	7.75	86.36
	NEMA 34 with 14mm shaft (MD3450/3475)	x	x	x	x		37	87.50	95.00	95.00	7.75	86.36
	SMH82-B8/14	x	x	x	x		67	85.75	95.25	95.00	10.75	95.25
	SMH82-B5/19 / SMH100-B5/19 / MH105-B5/19	x	x	x			77	99.00	107.95	107.50	10.00	107.95
	MH105-B9/19	x	x	x			J4	95.75	96.00	97.50	10.75	95.25
	P3 (planetary gear)	x	x				P3	105.25	95.00	95.00	19.00	82.00
	P4 (planetary gear)	x	x				P4	111.50	95.00	104.00	31.00	80.00
	PE3 (planetary gear)	x	x				N6	89.50	80.00	95.00	10.00	80.00
	PE4 (planetary gear)	x	x				N8	94.50	80.00	95.00	10.00	80.00
B100 V100	SMH82-B5/19 / SMH100-B5/19 / MH105-B5/19	x	x				77	107.50	107.95	140.00	11.50	107.95
	MH145-B5/24 or SMH142-B5/24	x	x				87	115.34	142.87	140.00	20.00	142.88
	MH105-B6/24 or SMH115-B7/24	x	x				J5	112.50	114.30	140.00	17.00	114.30
	HJ155	x	x				J6	128.25	152.40	140.00	20.00	142.88
	P4 (planetary gear)	x	x				P4	125.00	107.95	140.00	18.00	98.00
	P5 (planetary gear)	x	x				P5	158.00	120.65	140.00	40.00	114.00
B125	MH145-B5/24 or SMH142-B5/24	x	x				87	155.00	139.70	184.00	22.50	150.00
	HJ155	x	x				J6	155.00	140.00	184.00	28.50	155.00
	MH205-B5/38	x	x				J7	188.00	205.00	184.00	27.50	205.00
	P5 (planetary gear)	x	x				P5	195.00	139.70	184.00	32.50	150.00
	P7 (planetary gear)	x	x				P7	220.00	145.00	184.00	55.00	150.00

(1): PD3 = distance between spindle and motor shaft. Tolerance:  $\pm 3$ mm, as the toothed belt is tensioned over this distance!

\*: SMH60 with encoder option (A6/7) cannot be connected to the ETB32 with parallel mounting, use option C6/7 if necessary!

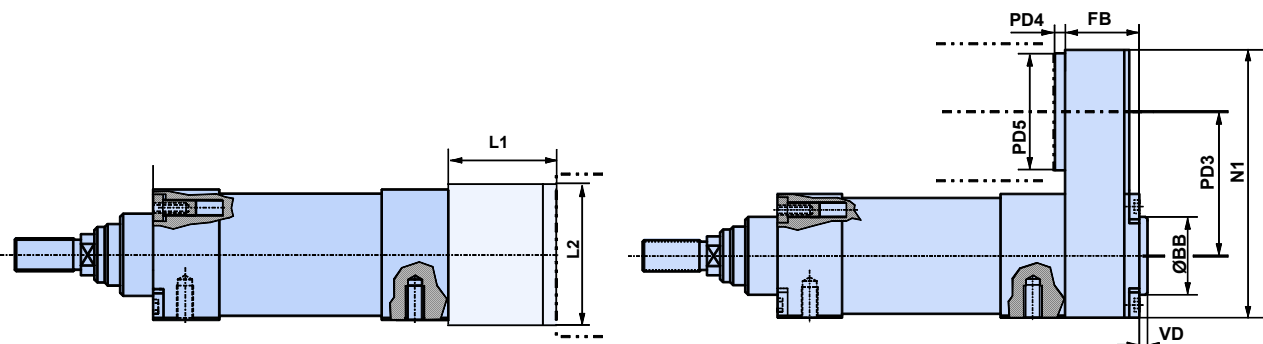

# Accessories

Stated in mm

## Configuration of the thrust rod

### External thread

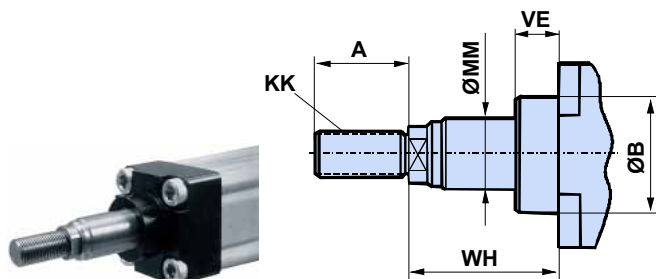

External thread (delivery standard)									
	A	KK	ØMM	Standard cylinder			IP65 rating		
	A	KK	ØMM	VE	WH	ØB	VE	WH	ØB
ET_32	22	M10x1.25	18	13	26	30	40	50	46
ET_50	32	M16x1.5	25	16	37	40	43	64	62
ET_80	40	M20x1.5	35	20	46	50	55	81	68
ET_100	54	M27x2.0	50	20	51	65	60	91	89
ETB125	71.5	M36x2.0	70	20	68	90	-	-	-

### Internal thread

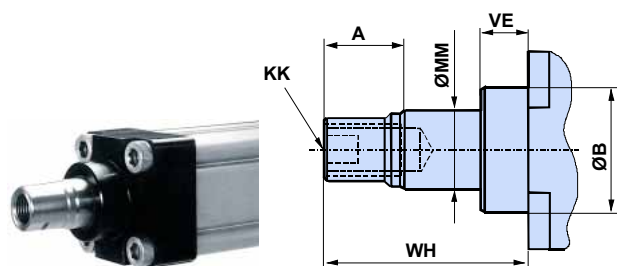

Internal thread									
	A	KK	ØMM	Standard cylinder			IP65 rating		
	A	KK	ØMM	VE	WH	ØB	VE	WH	ØB
ET_32	14	M10x1.25	18	13	32	30	40	56	46
ET_50	24	M16x1.5	25	16	50	40	43	77	62
ET_80	29	M20x1.5	35	20	59	50	55	94	68
ET_100	40	M27x2.0	50	20	73	65	60	113	89
ETB125	50	M36x2.0	70	20	99.5	90	-	-	-

### Rod clevis



	Order no.	KK	CL	CM	LE	CE	AV	ER	ØCK (h11/E9)	K	L
ET_32	4309	M10x1.25	26.0	10.2 <sup>+0.13/-0.05</sup>	20	40	20	14	10	17	5
ET_50	4312	M16x1.5	39.0	16.2 <sup>+0.13/-0.05</sup>	32	64	32	22	16	24	8
ET_80	4314	M20x1.5	52.5	20.1 <sup>+0.02/-0.0</sup>	40	80	40	30	20	30	10
ET_100	4331	M27x2.0	72.0	30.0 <sup>+0.6/-0.2</sup>	54	110	56	35	30	41	10
ETB125	413-042-195	M36x2.0	83.0	35	72	144	72	50	35	55	14

Listed in the order code of the cylinder, the order number is only for ordering spare parts.

## Spherical rod eye

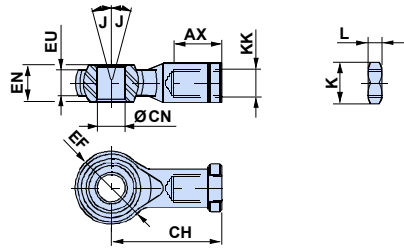

	Order no.	ØCN (H9)	EN (h12)	EU	AX	CH	ØEF	KK	J°	K	L
ET_32	4078-10	10	14	10.5	20	43	28	M10x1.25	13	17	5
ET_50	4078-16	16	21	15.0	28	64	42	M16x1.5	15	24	8
ET_80	4078-20	20	25	18.0	33	77	50	M20x1.5	14	30	10
ET_100	4078-27	30	37	25.0	51	110	70	M27x2.0	15	41	10
ETB125	4078-36	35	43	28.0	56	125	80	M36x2.0	15	55	14

Listed in the order code of the cylinder, the order number is only for ordering spare parts.

## Flexible coupling

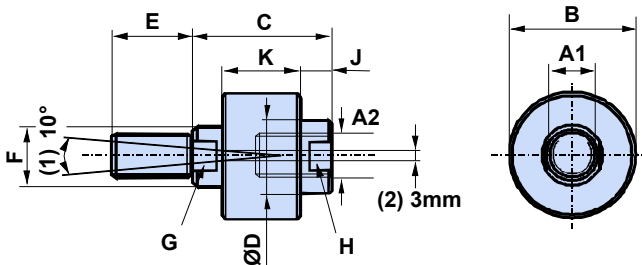

### For mounting at the extremity of the thrust rod

- ◆ Balances misalignments
- ◆ Enlarges the mounting tolerance
- ◆ Simplifies the cylinder mounting
- ◆ Increases the service life of the cylinder guidings
- ◆ Compensates the offset between components and relieves the guiding from lateral force influences
- ◆ The traction/thrust force bearing capacity is maintained

(1): Angle offset

(2): Axial offset

A2: Thread depth=E

	Order no.	A1	A2	B	C	ØD	E	F	G	H	J	K
ET_32	LC32-1010	M10x1.25	M10x1.25	40	51	19	19	16	13	16	13	26
ET_50	LC50-1616	M16x1.5	M16x1.5	54	59	32	29	25	22	29	14	33
ET_80	LC80-2020	M20x1.5	M20x1.5	54	59	32	29	25	22	29	14	33
ET_100	LC100-2727	M27x2.0	M27x2.0	89	102	51	51	38	32	43	19	64
ETB125	LC125-3636	M36x2.0	M36x2.0	102	112	57	57	44.5	38	49.3	22	70

Not listed in the cylinder order code, please order separately.

# Mounting options

## Rod guiding



The outrigger bearing unit performs the following tasks:

- ⇒ **Rotation protection for higher torques**
- ⇒ **Absorption of lateral forces**
- ⇒ **Relieves the cylinder of lateral forces**

The additional stability and precision is ensured by 2 hardened steel guiding rods in connection with 4 linear ball bearings.

**Not available for ETB125, not possible with IP65 rating**

### Rigidity of the cylinder with outrigger bearing

ET\_32 with outrigger bearing

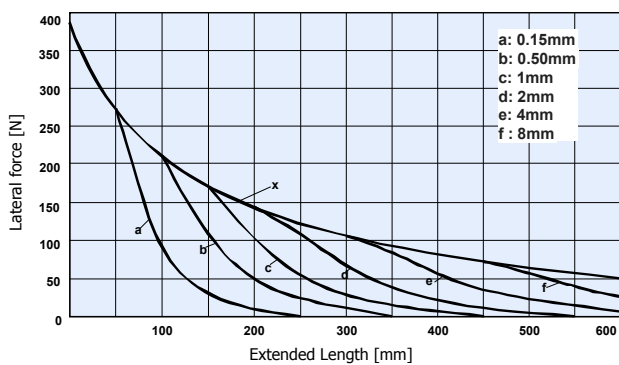

ET\_50 with outrigger bearing

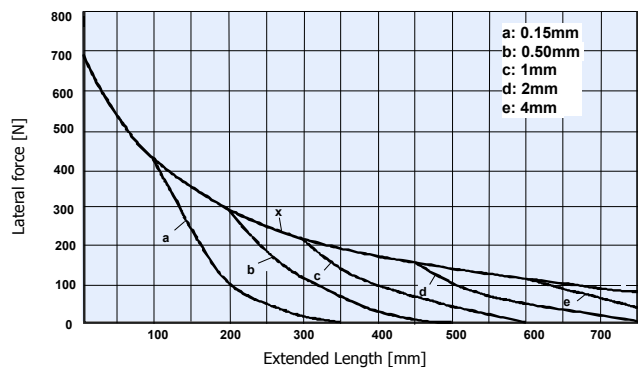

ET\_580 with outrigger bearing

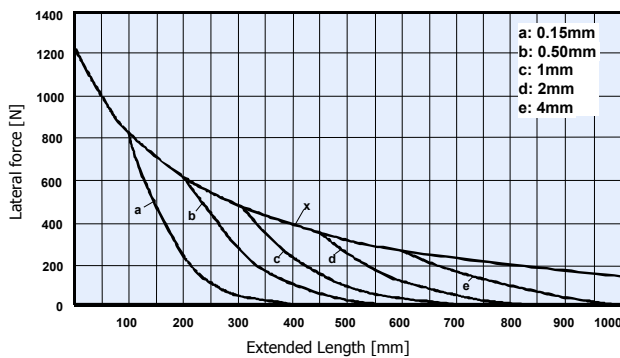

ET\_100 with outrigger bearing

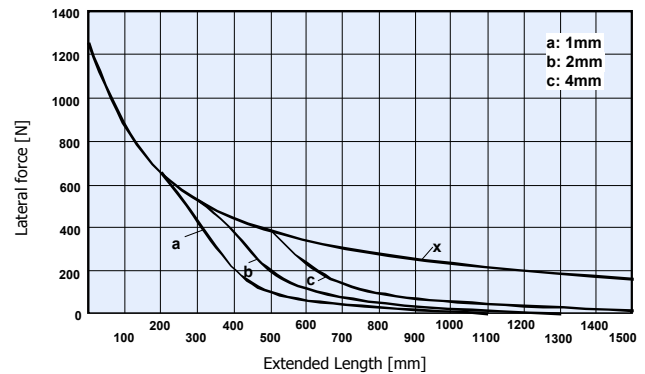

a, b, ...: deflection  
x: Deflection with maximum load

### Deflection

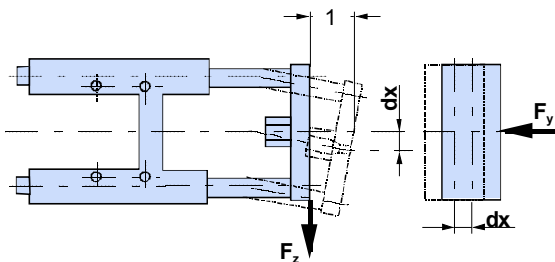

1: Stroke  
dx: deflection  
valid for  $F_z$  or  $F_y$   
M: Torsional load

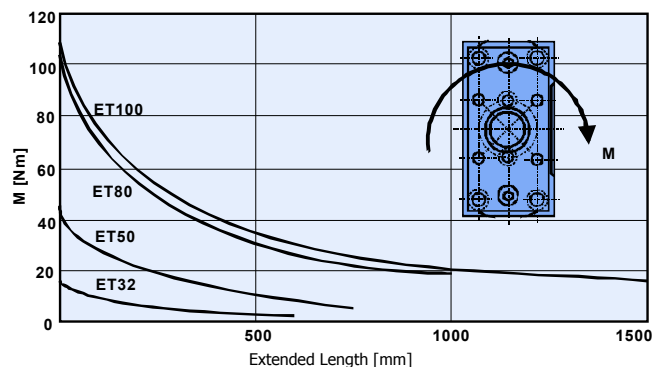

## Dimensions of ET outrigger bearing

	ET_32	ET_50	ET_80	ET_100
Model	32-2800R	50-2800R	80-2800R	100-2800R
A1	50	70	105	130
A2	97	137	189	213
B1	45	63	100	120
B2	90	130	180	200
B3	78	100	130	150
B4	32.5	46.5	72	89
B5	50	72	106	131
B6	4	19	21	24.5
B7	12	15	20	20
B8	61	85	130	150
ØC1	12	20	25	25
C2	73.5	103.5	147	171.5
C3	50	70	105	130
ØD1	6.6	9	11	11
ØD2	11	14	17	17
ØD5	M6	M8	M10	M10
E (Depth)	10	10	10	10
E1 (Depth)	12	16	20	20
E2 (Depth)	7	9	11	11
ØF1	30	40	50	65
G1	17	27	32	55
H1	81	119	166	190
H2	11.7	4.2	15	20.5
L1+*	150	192	247	290
L2	120	150	200	220
L3+*	15	24	24	24
L4	71	79	113	128
L5	64	89	110	138
N1	17	24	30	38
P1	36	42	50	49
P2	31	44	52	51
P3	40	50	70	70
Mass	970g	2560g	6530g	8760g
Additional mass / 100mm stroke	175g	495g	770g	770g

+\* = Measure + length of desired stroke **Definition of stroke** (see page 16)

N1: Hexagon head, outrigger bearing not possible with IP65 rating!

For the ET\_100, a larger coupling piece is used (concerns G1 and N1)

For the ET\_80 and the ET\_100, the standard pneumatic outrigger bearing modules cannot be used, ØF1 must be bored up to 50 mm for ET\_80 (from 45mm) and to 65mm for ET\_100 (from 55mm).

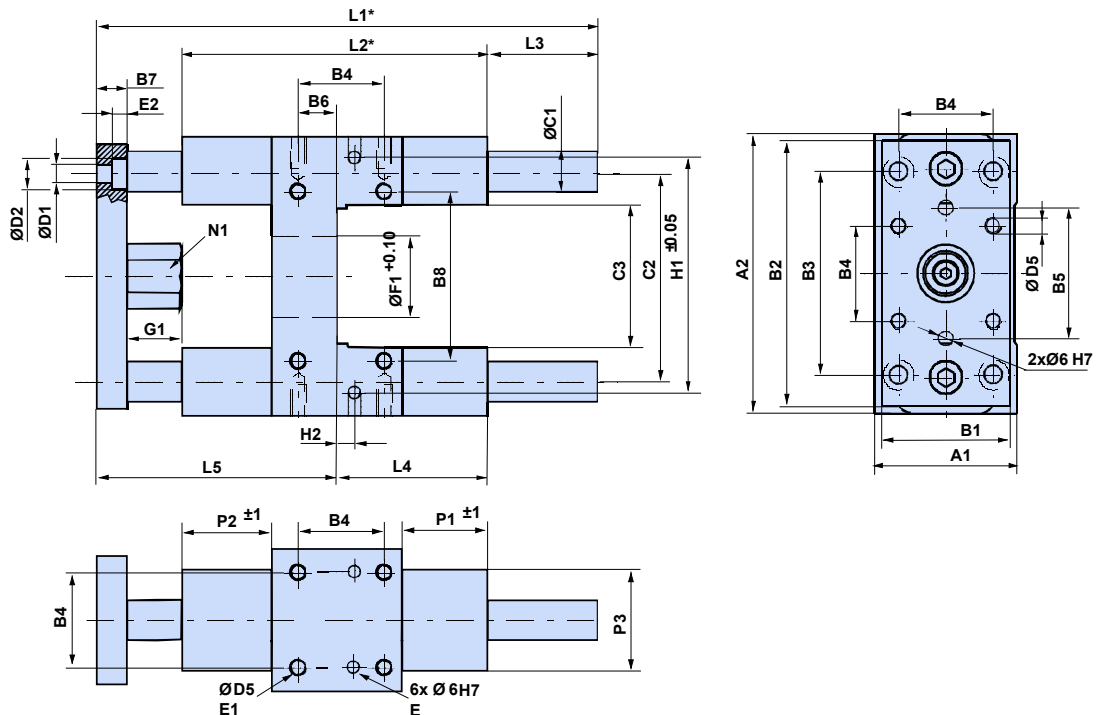

The hole pattern is suitable for Parker pneumatic modules, e.g. grippers and pivoting units

## Centre trunnion mounting

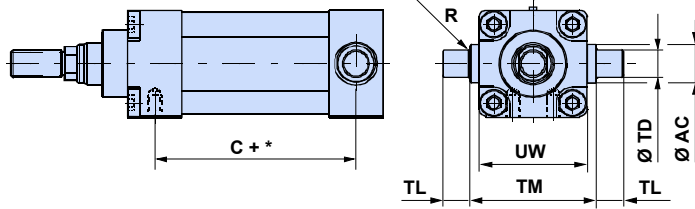

	C+*	UW	ØTD**	R	TL***	TM	ØAC
ET_32	stroke_dependent (see page 15)	46.5	12	0.8	12	50	18
ET_50	stroke_dependent (see page 15)	63.5	16	0.8	16	75	25
ET_80	stroke_dependent (see page 15)	95.3	20	0.8	20	110	30
ET_100	stroke_dependent (see page 15)	114.3	25	1.6	25	132.5	40
ETB125	stroke_dependent (see page 15)	139.7	32	2.0	32	149.7	45

+\* =Measure + length of desired stroke **Definition of stroke** (see page 16)

\*\* : ØTD according to ISO tolerance field h7

\*\*\* : TL according to ISO tolerance field e9

## Rear eye mounting

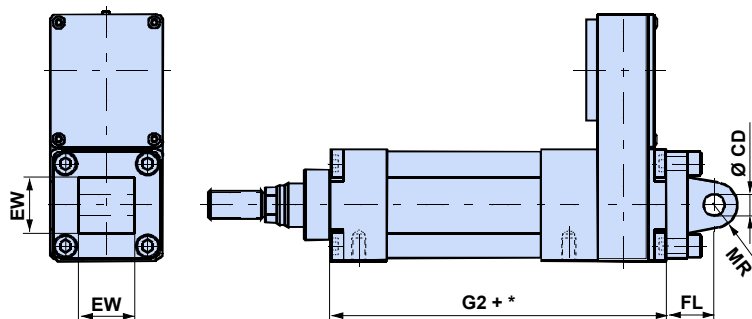

Only for parallel / reverse drive

	Order no.	G2+*	EW	ØCD	MR (H9)	FL ±0.2
ET_32	32-2800C	stroke_dependent (see page 15)	26	10	10	22
ET_50	50-2800C	stroke_dependent (see page 15)	32	12	12	27
ET_80	80-2800C	stroke_dependent (see page 15)	50	16	16	36
ET_100	100-2800C	stroke_dependent (see page 15)	60	20	20	41
ETB125	413-042420	stroke_dependent (see page 15)	70	25	25	50

+\* =Measure + length of desired stroke **Definition of stroke** (see page 16)

Listed in the order code of the cylinder, the order number is only for ordering spare parts.

## Rear clevis

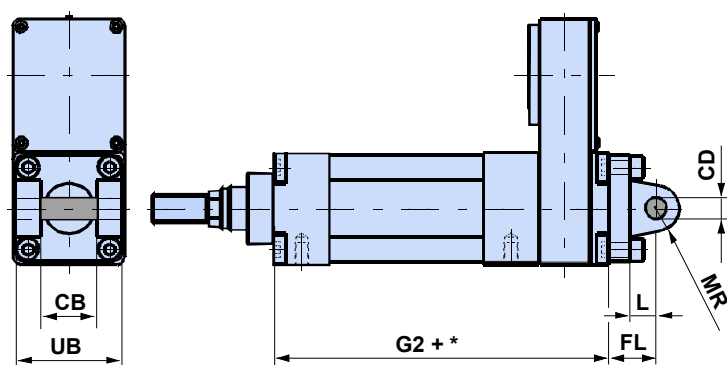
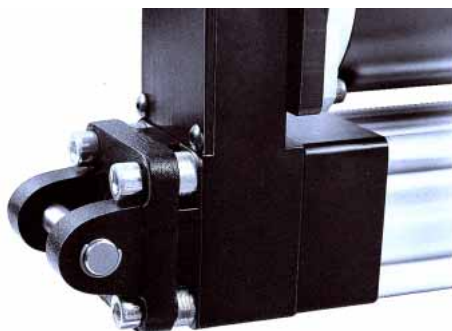

Only for parallel / reverse drive

	Order no.	G2+*	UB (h14)	CB (H14)	ØCD (H9)	MR	L	FL ±0.2
ET_32	32-2800B	stroke_dependent (see page 15)	45	26	10	10	13	22
ET_50	50-2800B	stroke_dependent (see page 15)	60	32	12	12	16	27
ET_80	80-2800B	stroke_dependent (see page 15)	90	50	16	16	22	36
ET_100	100-2800B	stroke_dependent (see page 15)	110	60	20	20	27	41
ETB125	125-2800B	stroke_dependent (see page 15)	130	70	25	25	30	50

+\* =Measure + length of desired stroke **Definition of stroke** (see page 16)

Listed in the order code of the cylinder, the order number is only for ordering spare parts.



## Bearing block

Counterpiece of the rear clevis

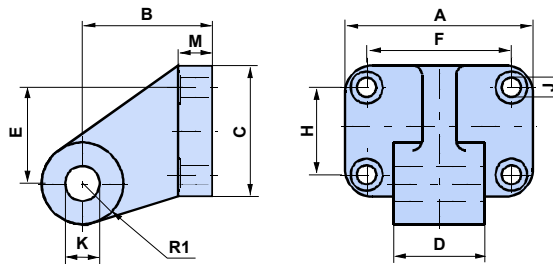

	Order no.	A	B (JS15)	C	D	E (JS14)	F (JS14)	H	ØJ (H13)	ØK (H9)	M	R1
ET_32	32-2800T	51	32	31	25.5	21	38	18	6.6	10	8	10
ET_50	50-2800T	65	45	45	31.0	33	50	30	9.0	12	12	13
ET_80	80-2800T	86	63	60	49.0	47	66	40	11.0	16	14	15
ET_100	100-2800T	96	71	70	59.0	55	76	50	11.0	20	15	21
ETB125	125-2800T	124	90	90	69.0	70	94	60	14.0	25	20	25

Not listed in the cylinder order code, please order separately.

## Installation flanges



Front plate not possible with IP65 rating

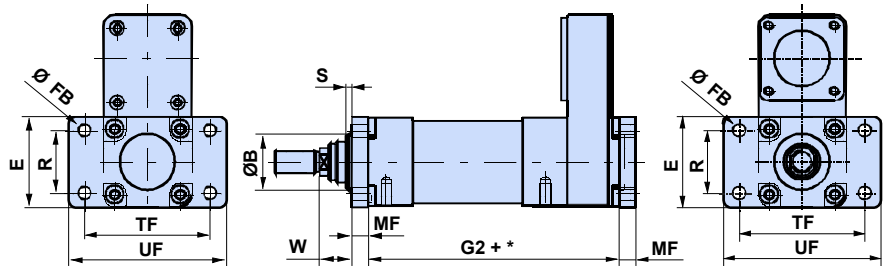

Rear plate only for parallel / reverse drive

	Order no. (1 piece)	G2+*	UF	E	TF	ØFB	R	W	MF	ØB	S
ET_32	32-2800A	<b>stroke_dependent</b> (see page 15)	80	48	64	7	32	16	10	30	3
ET_50	50-2800A	<b>stroke_dependent</b> (see page 15)	110	65	90	9	45	25	12	40	4
ET_80	80-2800A	<b>stroke_dependent</b> (see page 15)	150	95	126	12	63	30	16	50	4
ET_100	100-2800A	<b>stroke_dependent</b> (see page 15)	180	110	150	14	75	35	16	65	4
ETB125	ET125MTG-JBSC	<b>stroke_dependent</b> (see page 15)	205	140	180	17	90	53	20	90	0

+\* =Measure + length of desired stroke **Definition of stroke** (see page 16)

Listed in the order code of the cylinder, the order number is only for ordering spare parts.

## Foot mounting



Only for parallel / reverse drive

Front foot mounting plate not possible with IP65 rating.

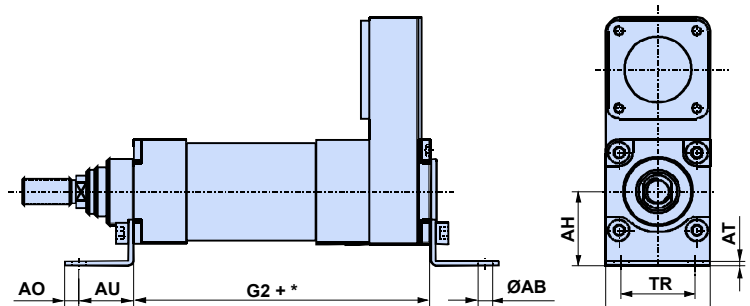

	Order no. (1 piece)	G2+*	AH	AT	TR	ØAB (H14)	AO	AU	TW
ET_32	32-2800D	<b>stroke_dependent</b> (see page 15)	32	3	32	7	8	24	48
ET_50	50-2800D	<b>stroke_dependent</b> (see page 15)	45	3	45	9	12	32	65
ET_80	80-2800D	<b>stroke_dependent</b> (see page 15)	63	4	63	12	15	41	95
ET_100	100-2800D	<b>stroke_dependent</b> (see page 15)	71	6.5	75	14	17	41	115
ETB125	ET125MTG-BBSC	<b>stroke_dependent</b> (see page 15)	90	8.3	90	17	25	45	140

+\* =Measure + length of desired stroke **Definition of stroke** (see page 16)

Listed in the order code of the cylinder, the order number is only for ordering spare parts.

## Mounting flanges

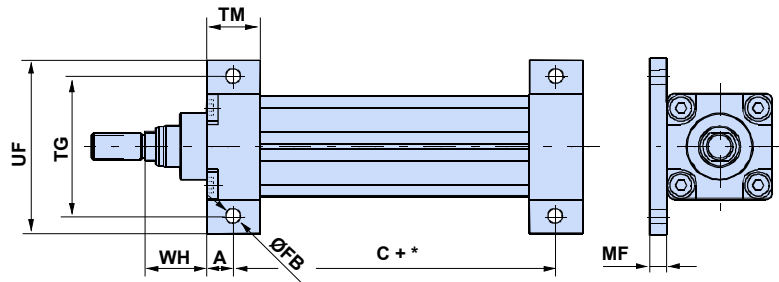

	Order no. (1 piece)	C+*	WH	TG	UF	ØFB	TM	MF	A
ET_32	1440.079	stroke_dependent (see page 15)	Dimensions (see page 15)	62	78	6.6	25	8	14
ET_50	1441.093	stroke_dependent (see page 15)	Dimensions (see page 15)	84	104	9	30	10	16
ET_80	ET80E24	stroke_dependent (see page 15)	Dimensions (see page 15)	120	144	11	40	12	21
ET_100	ET100E14	stroke_dependent (see page 15)	Dimensions (see page 15)	150	185	13	50	12	27.5
ETB125	ET125MTG-GBSC	stroke_dependent (see page 15)	Dimensions (see page 15)	175	210	17	70	20	35

+\* =Measure + length of desired stroke **Definition of stroke** (see page 16)

Listed in the order code of the cylinder, the order number is only for ordering spare parts.

# Initiators / limit switches

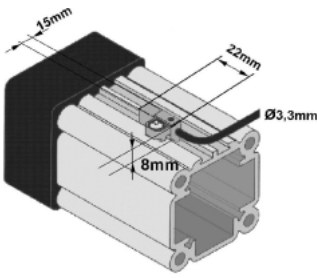

The cylinder profile has two t-grooves for the mounting of initiators. The initiators can be freely positioned along the profile (access to the lubricating hole must be granted).

ET\_100 and ETB125 have these longitudinal grooves on all sides, ET\_32, ET\_50 and ET\_80 only on one side of the profile.

The permanent magnet integrated into the spindle nut, actuates the initiators.

## The following initiator types are available for the ET cylinder series:

### ⇒ Hall effect sensor

- ◆ Normally closed contact or normally open contact
- ◆ electronic
- ◆ LED display
- ◆ medium costs
- ◆ long life

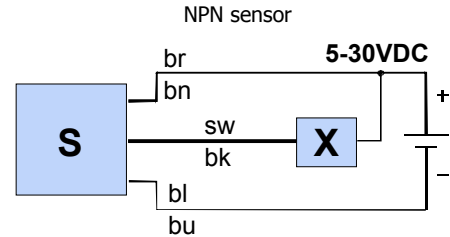
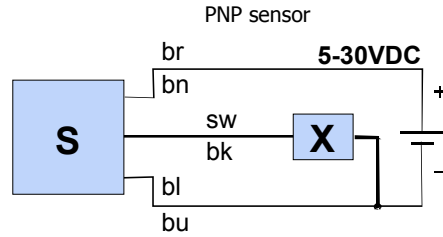

S: Switch / X: Load

Hall effect sensors								
Type	Function	LED	Logic	Cables	Switching current	Electric current drain	Utilities	Switching frequency
SMH-1P*	Normally open contact	Green	PNP	1.5m	max.150mA	7mA at 12VDC 14mA at 24VDC	5 - 30VDC	max.500Hz
SMH-1N*	Normally open contact	Red	NPN					
SMC-1P*	Normally closed contact	Yellow	PNP					
SMC-1N*	Normally closed contact	White/Red	NPN					

\*If you require only 150mm of cable length instead of 1.5m, please add a "C" to your order code. Example: SMH-1PC. Use only SMC-1P with COMPAX.

## Initiator / limit switch - mounting



**No initiator is to be mounted in the area of the lubrication hole. If you should need an initiator at this position due to your application, please contact us.**

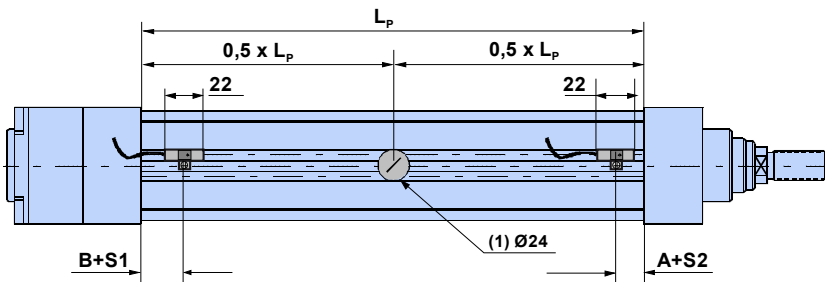

(1): Lubrication bore



S1, S2: **Safety travels** (see page 16)

A, B: Switching distances

Stated in mm

Switching distance [mm]	A: on the thrust rod side	B: on the motor side
ET_32M05	15	66
ET_32M10	15	66
ET_50M05	19	83
ET_50M10	19	86
ET_50M16	19	90
ET_80M05	23	68
ET_80M10	23	87
ET_80M25	23	94
ETB100M05	15	101
ETB100M10	15	120
ETB100M20	15	138
ETB100M40	15	148
ETV100M05	15	121
ETV100M10	15	162
ETB125M05	69	72
ETB125M10	69	102
ETB125M20	69	102
ETB125M50	69	125

# Order code

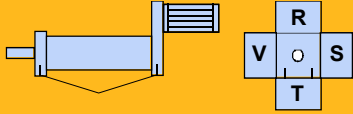
ET series	Order example: ETB50M05PA67FMA600A					ET	B	50	M05	P	A
<b>Design</b>											
Standard NEMA motors (ET32 to 80)							S				
metric motors and gears as well as special NEMA motors (ET32 to 125)							B				
like version B, but with increased lifetime (only ET32&ET100)							V				
<b>Model /size</b>											
								32			
								50			
								80			
								100			
								125			
<b>Screw pitch Mxx in mm</b>											
ET_32	ET_50	ET_80	ETB100	ETV100	ET_125						
X	X	X	X	X	X				M05		
X	X	X	X	X	X				M10		
	X								M16		
			X		X				M20		
		X							M25		
			X						M40		
					X				M50		
<b>Motor mounting position</b>											
direct (inline)										L	
Parallel										P	
										M	
										N	
										Q	
antiparallel										R	
										S	
										T	
										V	
with parallel motor mounting, the motor could, depending on the profile orientation, interfere with the initiators (ET_32, 50, 80) and block the lubrication hole (see page 8)											
<b>Transmission ratio</b> (combinations (see page 17))											
1:1	in-line, parallel, antiparallel										A
1.5:1	parallel, antiparallel (only drives with shaft $\varnothing > 9\text{mm}$ , not ET_50)										B
2:1	parallel, antiparallel										D
1:1.5	parallel, antiparallel (only ET_32)										Z

67	F	M	A	600	A							
						<b>Protection class</b>						For IP65, contact the supplier in order to discuss conditions of use and environment.
						<b>Stroke in mm</b>						Definition of stroke (see page 15 – definition of stroke)
						A IP	company internal designation IP65 rating (not for ETB125)					ET_32: 50 - 0750 ET_50: 50 - 1000 ET_80: 100 - 1500 ET_100: 100 - 1500 ETB125: 100 - 2400
						<b>Housing orientation</b>						The profile orientation (see page 8) does also define the position of the lubrication hole.
						A B C	3 hrs (not with motor position M) 6 hrs (not with motor position N) 9 hrs (not with motor position Q) 12 hrs/standard (not with motor position P)					
						<b>Thrust rod</b>						*not for ETB125 and not with IP65
						M F C S R	External thread (Standard metrical) Internal thread Rod clevis Spherical rod eye Outtrigger bearing*					
						<b>Mounting type</b>						Stainless versions of the mounting options on request *not for motor position L ** not with IP65
						B C D E F G H J N X	Foot mounting* Rear clevis mounting* Centre trunnion mounting Rear eye mounting* Standard (Thread at cylinder profile) Mounting flanges Rear plate* Front plate** Front- and rear plate* Customer specific					
						<b>Motor mounting options</b> (combinations (see page 17))						
	Fitting edge	pitch diameter	∅Shaft	Shaft length	Note							
20	38.1	66.6	6.35	20.8		NEMA 23	prepared for NEMA standard motors					
30	73	98.42	9.52	31.5		NEMA 34						
40	55.54	125.5	15.87	50		NEMA 42						
20	38.1	66.6	9.525	20.8	M5 bore	NEMA 23 with 9.525mm shaft	prepared for metric motors and special NEMA motors					
30	73	98.42	12.7	30.23		NEMA 34 with 1/2inch shaft						
37	73	98.42	14	30		NEMA 34 with 14mm shaft	(47: SMH60 with encoder A6 / A7 cannot be mounted parallelly on ET_32.					
47	40	63	9	20		MH56-B5/9, SMH60-B8/9						
57	60	75	11	23		MH70-B5/11, SMH60-B5/11						
67	80	100	14	30		SMH82-B08/14						
77	95	115	19	40		SMH82-, SMH100- or, MH105-B5/19						
87	130	165	24	50		MH145-B5/24, SMH142-B5/24						
J4	80	100	19	40		MH105-B9/19						
J5	110	130	24	50		MH105-B6/24 ,SMH115-B7/24						
J6	130	165	32	58		HJ155						
J7	180	215	38	80		MH205-B5/38						
P3	60	75	16	48		P3	prepared for planetary gearbox					
P4	70	85	22	56		P4						
P5	90	120	32	88		P5						
P7	130	165	40	112		P7						
N6	40	52	14	35	Internal thread M5	PE3						
N8	80	100	20	40		PE4						
90							prepared for non-standard motors / gears (only motors/gears with keyway can be fitted)					

Further information:

[www.parker-eme.com/et](http://www.parker-eme.com/et)

We reserve the right to make technical changes. The data correspond to the technical state at the time of printing.  
© 2007 Parker Hannifin Corporation

192-550011N16

June 2008



Parker Hannifin GmbH & Co. KG  
**Electromechanical Automation**  
Robert-Bosch-Straße 22  
D-77656 Offenburg, Germany  
phone +49 (0)781 / 509-0  
fax +49 (0)781 / 509-98176  
sales.automation@parker.com  
[www.parker-automation.com](http://www.parker-automation.com)

Autoryzowany dystrybutor Parker:

**ARA**  
**PNEUMATIK**  
53-012 Wrocław tel. 71 364 72 82  
ul. Wyścigowa 38 fax 71 364 72 83  
[www.arapneumatik.pl](http://www.arapneumatik.pl)

