

Electric Tubular Motor

ETT Series

Technical Manual

Rev. 1.0 30th June 2013

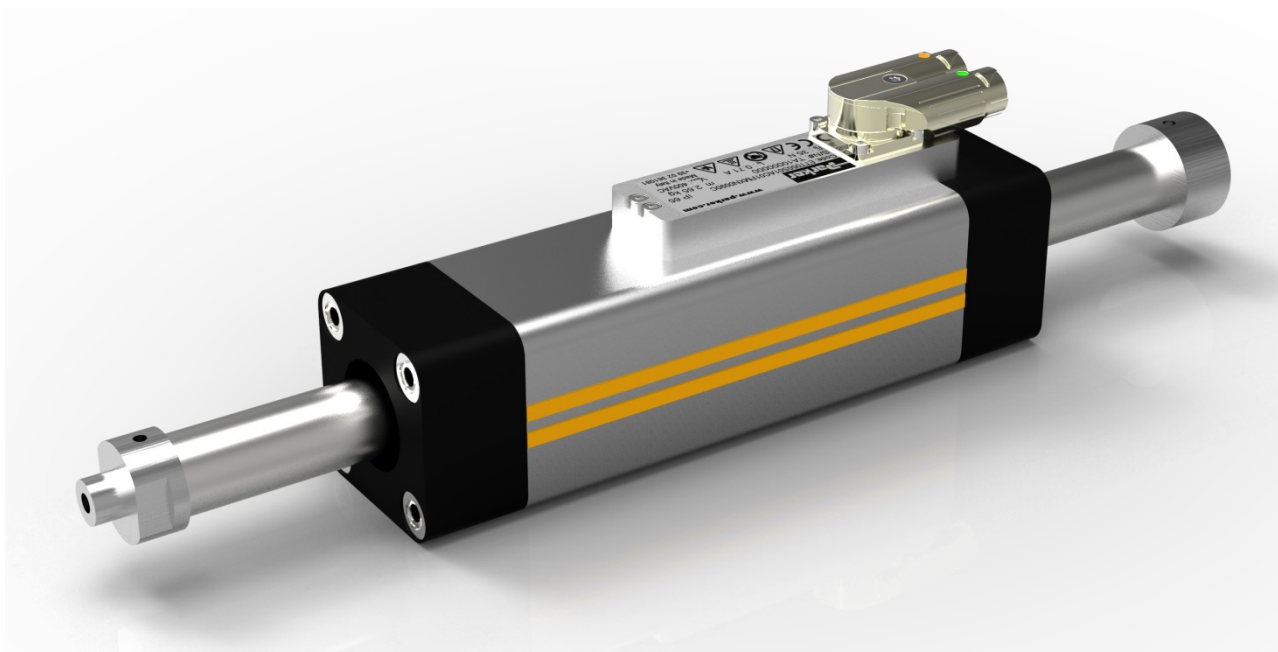

Autoryzowany dystrybutor Parker:

ARA

PNEUMATIK

53-012 Wrocław tel. 71 364 72 82
ul. Wyścigowa 38 fax 71 364 72 83

www.arapneumatik.pl





Compliance with «CE» directives

The ETT tubular servomotors Series are in accordance with the following Directives:

- **2006/95/EC** Low voltage Directive (LVD)
- **2004/108/CE** EMC Directive

Have been designed, manufactured and tested to the following specifications:

- CEI EN61000-4-2:1996 + A1 (99) + A2 (01)
- CEI EN61000-4-3:2007
- CEI EN61000-4-4:2006 + EC (08) + A1 (10)
- CEI EN61000-4-6:2009
- CEI EN61000-4-8:1997 + A1 (01)
- CEI EN55011:2009
- CEI EN61000-6-2:2006
- CEI EN61000-6-4:2007
- CISPR 16-1:1999

Compliance with these standards requires servo motors to be mounted in accordance with the recommendations given in this user manual.



PARKER HANNIFIN MANUFACTURING SRL
Electromechanical Division Europe (EME)

Via C. Gounod, 1

I-20092 Cinisello Balsamo (MI)

Tel : +39 02 361081

Fax : +39 02 36108400

www.parker.com/eme

em-motion@parker.com

Table of Content

1. INTRODUCTION	6
1.1. Purpose and intended audience	6
1.2. Safety	6
1.2.1. Principle	6
1.2.2. General Safety Rules	7
2. PRODUCT DESCRIPTION	9
2.1. Overview	9
2.2. Applications	9
2.3. General Technical Data	10
2.4. Product Code	11
2.4.1. Complete ETT Part Number Codes	11
2.4.2. Rod Part Number Codes	12
2.4.3. Coil Part Number Codes	13
2.4.4. Table of Stroke / Length of Rod	13
3. TECHNICAL DATA	16
3.1. Motor selection	16
3.1.1. Altitude derating	16
3.1.2. Temperature derating	16
3.2. ETT Characteristics: Force, speed, current, power	17
3.2.1. ETT025 Electric Specifications	18
3.2.2. ETT025 Thermal Specifications	18
3.2.3. Force / velocity profiles ETT025	19
3.2.4. ETT032 Electric Specifications	20
3.2.5. ETT032 Thermal Specifications	20
3.2.6. Force / velocity profiles ETT032	21
3.2.7. ETT050 Electric Specifications	22
3.2.8. ETT050 Thermal Specifications	22
3.2.9. Force / velocity profiles ETT050	23
3.3. Dimension drawings	24
3.3.1. ETT025	24
3.3.2. ETT032	25
3.3.3. ETT050	26
3.4. Motor Mounting	27
3.4.1. Motor mounting	27
3.4.2. Accessories for mounting	29
3.5. Cooling	34
3.5.1. Natural cooled motor	34
3.6. Thermal Protection	34
3.6.1. Temperature measurement with KTY sensors:	34
3.7. Power Electrical Connections	36
3.7.1. Wires sizes	36
3.7.2. Mains supply connection diagrams	37
3.8. Feedback system	38
3.8.1. Internal feedback option	38
3.8.2. External position sensor	39
3.8.3. Cables	39
4. COMMISSIONING, USE AND MAINTENANCE	40
4.1. Instructions for commissioning, use and maintenance	40
4.1.1. Equipment delivery	40
4.1.2. Handling	40
4.1.3. Storage	40
4.2. Installation	41
4.2.1. Mounting	41
4.2.2. Preparation	41
4.3. Electrical connections	42



4.3.1.	Cable connection.....	43
4.3.2.	Encoder cable handling.....	43
4.4.	Maintenance Operations.....	44
4.4.1.	Summary maintenance operations.....	44
4.5.	Troubleshooting	45

1. INTRODUCTION

1.1. Purpose and intended audience

This manual contains information that must be observed to select, install, operate and maintain PARKER ETT servomotors.

Installation, operation and maintenance of the equipment should be carried out by qualified personnel. A qualified person is someone who is technically competent and familiar with all safety information and established safety practices; with the installation process, operation and maintenance of this equipment; and with all the hazards involved.

Reading and understanding the information described in this document is mandatory before carrying out any operation on the motors. If any malfunction or technical problem occurs, that has not been dealt with in this manual, please contact PARKER for technical assistance. In case of missing information or doubts regarding the installation procedures, safety instructions or any other issue tackled in this manual, please contact PARKER as well.

PARKER's responsibility is limited to its servomotors and does not encompass the whole user's system. Data provided in this manual are for product description only and may not be guaranteed, unless expressly mentioned in a contract.

	<p><u>DANGER:</u> PARKER declines responsibility for any industrial accident or material damage that may arise, if the procedures and safety instructions described in this manual are not scrupulously followed.</p>
---	--





1.2. Safety





1.2.1. Principle

To operate safely, this equipment must be transported, stored, handled, installed and serviced correctly. Following the safety instructions described in each section of this document is mandatory. Servo motors usage must also comply with all applicable standards, national directives and factory instructions in force.

	<p><u>DANGER:</u> Non-compliance with safety instructions, legal and technical regulations in force may lead to physical injuries or death, as well as damages to the property and the environment.</p>
---	--

1.2.2. General Safety Rules

	<p>Forbidden for persons with heart pace makers Persons with heart pace makers are not allowed to handle or work with this product. Keep the necessary safety distance.</p>
	<p>Beware of the magnetic field The magnetic rod does contain strong magnets and exerts a strong pull on ferromagnetic objects. Non-compliance with the safety instructions may result in damages to computer drives and credit cards.</p>
	<p>Generality <u>DANGER:</u> The installation, commission and operation must be performed by qualified personnel, in conjunction with this documentation. The qualified personnel must know the safety (C18510 authorization, standard VDE 0105 or IEC 0364) and local regulations. They must be authorized to install, commission and operate in accordance with established practices and standards.</p>
	<p>Electrical hazard Servo drives may contain non-insulated live AC or DC components. Respect the drives commissioning manual. Users are advised to guard against access to live parts before installing the equipment. Some parts of the motor or installation elements can be subjected to dangerous voltages, when the motor is driven by the inverter , when the motor rotor is manually rotated, when the motor is driven by its load, when the motor is at standstill or stopped. For measurements use only a meter to IEC 61010 (CAT III or higher). Always begin using the highest range. CAT I and CAT II meters must not be used on this product. Allow at least 5 minutes for the drive's capacitors to discharge to safe voltage levels (<50 V). Use the specified meter capable of measuring up to 1000 V dc & ac rms to confirm that less than 50 V is present between all power terminals and between power terminals and earth. Check the drive recommendations. The motor must be permanently connected to an appropriate safety earth. To prevent any accidental contact with live components, it is necessary to check that cables are not damaged, stripped or not in contact with a rotating part of the machine. The work place must be clean, dry. General recommendations : <ul style="list-style-type: none"> - Check the wiring circuit - Lock the electrical cabinets - Use standardized equipment </p>

	<p>Mechanical hazard Servomotors can accelerate in milliseconds. Running the motor can lead to other sections of the machine moving dangerously. Moving parts must be screened off to prevent operators coming into contact with them. The working procedure must allow the operator to keep well clear of the danger area.</p>
	<p>Burning Hazard Always bear in mind that some parts of the surface of the motor can reach temperatures exceeding 100 °C.</p>
	<p>Heavy object Heavy objects should not be lifted by a single person.</p>
	<p>Beware of crush hazard/hand injuries The forcer may move unexpectedly. Always isolate all sources of electrical supply before working on the equipment. General hazard. Follow the advice given.</p>

2. PRODUCT DESCRIPTION

2.1. Overview

The ETT servomotors Series from PARKER is an innovative direct drive solution designed for industrial applications. The electric tubular motor ETT is a direct thrust linear motor actuator, ideally suited for all kind of linear handling and pick & place applications.

Advantages

- Three lengths and two sizes according to pneumatic ISO flange norm (DIN ISO 15552:2005-12) for simplified mechanical integration
- Reduced mechanical complexity delivers a high energy efficiency and reduces maintenance
- High Force range up to 128 N continuous and 512 N of peak force makes the ETT ideal for a wide range of applications
- High thermal efficiency improves reliability and increases mechanical life

2.2. Applications

- **Food, Pharmaceutical & Beverage**
- **Packaging Machines**
- **Material Handling**
- **Factory Automation**



2.3. General Technical Data

	ETT025	ETT032	ETT050
Motor type	Tubular permanent-magnet synchronous motor		
Magnets material	Neodymium Iron Boron – (NdFeB)		
Number of poles	2		
Type of construction	DIN ISO 15552:2005-12		
Degree of protection	IP67		
Cooling	Natural cooling		
Rated voltage	230 VAC		
Insulation of the stator winding	Class F according to IEC 60034-1 with potting		
Altitude	Up to 1000 m (IEC 60034-1)(for higher altitude see §3.1.1 for derating)		
Ambient temperature	0° C to +40 °C (IEC 60034-1)		
Storage temperature	-25... +70 °C		
Connection	Flying wires	Connectors	
Marking	CE		
Sensor	1 Vpp SinCos encoder feedback		
Thermal protection	KTY		
Remark	Customizations are possible on request		



2.4. Product Code

2.4.1. Complete ETT Part Number Codes

ETT	025	S1	1S	M	N	0030	C	
Frame size - 025 - 032 - 050								
Winding type - S1 - S2 - S3								
Connection & Feedback type - CS: SinCos feedback – Connectors - 1S: SinCos feedback – 1 m Flying leads - 2S: SinCos feedback – 2.5 m Flying leads - 3S: SinCos feedback – 5 m Flying leads								
Front / Rear “Rod End Mounting” - M : Male Thread / Cap End (M5 for ETT25, M6 for ETT32, M8 for ETT50) - F : Female Thread / Cap End (M5 for ETT25, M6 for ETT32, M8 for ETT50) - N : Male Thread / Male Thread (M5 for ETT25, M6 for ETT32, M8 for ETT50) - G : Female Thread / Female Thread (M5 for ETT25, M6 for ETT32, M8 for ETT50) - W : Linear Coupling / Cap End, LK70 for ETT25 - LK150 for ETT32, LK300 for ETT50 - I : Plastic Rod Eye - R : Plastic Rod Clevis								
Fix Field – N -								
Stroke (See table of stroke / length)								
Protection Class IP - C: IP67 Standard								
Optional Customized								

Note: All combinations are not possible – Contact Parker for checking.



2.4.2. Rod Part Number Codes

ETT-R	025	M	0040	
Frame size - 025 - 032 - 050				
Front / Rear "Rod End Mounting" - M : Male Thread / Cap End (M5 for ETT25, M6 for ETT32, M8 for ETT50) - F : Female Thread / Cap End (M5 for ETT25, M6 for ETT32, M8 for ETT50) - N : Male Thread / Male Thread (M5 for ETT25, M6 for ETT32, M8 for ETT50) - G : Female Thread / Female Thread (M5 for ETT25, M6 for ETT32, M8 for ETT50) - W : Linear Coupling / Cap End, LK70 for ETT25 - LK150 for ETT32, LK300 for ETT50 - I : Plastic Rod Eye - R : Plastic Rod Clevis				
Stroke (See table of stroke / length)				
Optional Customized				



2.4.3. Coil Part Number Codes

ETT	025	S1	1S	N	C	
Frame size						
- 025						
- 032						
- 050						
Winding type						
- S1						
- S2						
- S3						
Connection & Feedback type						
- CS: SinCos feedback – Connectors						
- 1S: SinCos feedback – 1 m Flying leads						
- 2S: SinCos feedback – 2.5 m Flying leads						
- 3S: SinCos feedback – 5 m Flying leads						
Fix Field – N -						
Protection Class IP						
- C: IP67 Standard						
Optional Customized						

2.4.4. Table of Stroke / Length of Rod

2.4.4.1. ETT025

Length of ROD [mm]	Weight of ROD [kg]	Stroke		
		S1 [mm]	S2 [mm]	S3 [mm]
205	0.212	20	20	20
215	0.224	30	30	30
245	0.26	60	60	60
275	0.295	90	90	90
305	0.331	120	120	120
335	0.367	150	150	150
365	0.403	180	180	180
395	0.439	210	210	210
425	0.475	240	240	240
455	0.51	270	270	270
485	0.546	300	300	300
515*	582	330	330	330
545*	0.618	360	360	360

* Needs specific mechanical mounting
Special length available under request

2.4.4.2. ETT032

Length of ROD [mm]	Weight of ROD [kg]	Stroke		
		S1 [mm]	S2 [mm]	S3 [mm]
221	0.389	30		
251	0.448	60	30	
281	0.507	90	60	30
311	0.566	120	90	60
341	0.625	150	120	90
371	0.684	180	150	120
401	0.743	210	180	150
431	0.802	240	210	180
461	0.861	270	240	210
491	0.92	300	270	240
521	0.98	330	300	270
551	1.038	360	330	300
581	1.097	390	360	330
611	1.156	420	390	360
641	1.215	450	420	390
671	1.274	480	450	420
701	1.333	510	480	450
731*	1.392	540	510	480
761*	1.451	570	540	510
791*	1.51	600	570	540
821*	1.569	630	600	570
851*	1.629	660	630	600

* Needs specific mechanical mounting
Special length available under request



2.4.4.1. ETT050

Lenght of ROD [mm]	Weight of ROD [kg]	Stroke		
		S1 [mm]	S2 [mm]	S3 [mm]
254	0.557	30		
284	0.625	60	30	
314	0.693	90	60	
344	0.761	120	90	
374	0.828	150	120	
404	0.896	180	150	
434	0.964	210	180	30
464	1.032	240	210	60
494	1.1	270	240	90
524	1.168	300	270	120
554	1.236	330	300	150
584	1.304	360	330	180
614	1.372	390	360	210
644	1.44	420	390	240
674	1.508	450	420	270
704	1.575	480	450	300
734	1.644	510	480	330
764	1.711	540	510	360
794	1.78	570	540	390
824	1.847	600	570	420
854	1.915	630	600	450
884*	1.983	660	630	480
914*	2.051	690	660	510
944*	2.119	720	690	540

* Needs specific mechanical mounting
Special length available under request

3. TECHNICAL DATA

3.1. Motor selection

3.1.1. Altitude derating

From 0 to 1000 m : no derating

1000 to 4000 m: force derating of 10% for each step of 1000 m for air cooled

3.1.2. Temperature derating

3.1.2.1. Natural cooled motor

The maximum ambient temperature for operation with natural cooling is 40 °C. It is possible to increase the ambient temperature above 40 °C, with a force reduction. The following formula provides an indication of the torque derating at low speed. Refer to PARKER technical support to confirm the exact values

At low speed the force derating is given by the following formula for an ambient temperature > 40°C.

$$Force_derating[\%] = 100 * \sqrt{\frac{(110^{\circ}C - Ambient_temperature^{\circ}C)}{70^{\circ}C}}$$



At high speed, the calculation is more complex, and the derating is much more important. Please refer to PARKER to a precise calculation of force derating according to the ambient temperature at high speed for a specific motor.

3.2. ETT Characteristics: Force, speed, current, power...

The force vs speed graph below shows the key Force, Speed and Power components listed in the specifications.

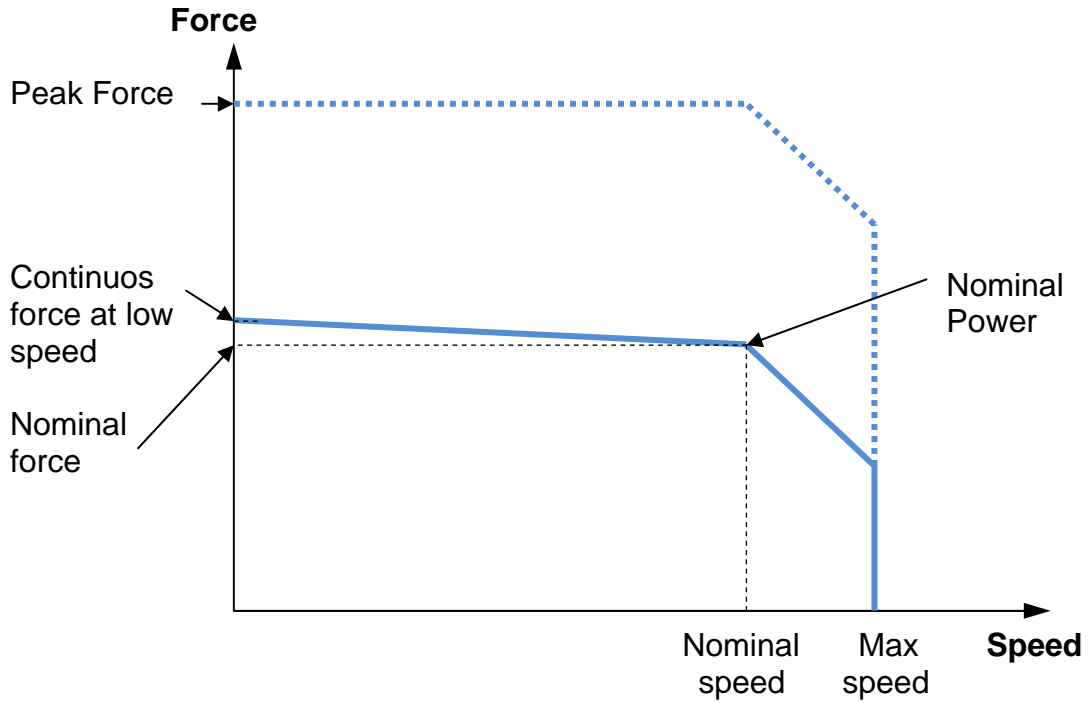



3.2.1. ETT025 Electric Specifications

ETT025	S1⁽¹⁾	S2⁽¹⁾	S3⁽¹⁾	Unit
Peak force ⁽²⁾ for 10 s	24	36	48	N
Peak current ⁽²⁾ for 10 s	2.8	2.8	2.8	A _{rms}
<i>Without heatsink plate</i>				
Continuous stall force ⁽²⁾	6	9	12	N
Continuous stall current ⁽²⁾	0.7	0.7	0.7	A _{rms}
<i>With heatsink plate 25 x 25 x 2.5 cm ⁽⁵⁾⁽⁶⁾</i>				
Continuous stall force ⁽²⁾	6.6	9.9	13.2	N
Continuous stall current ⁽²⁾	0.8	0.8	0.8	A _{rms}
Force constant (sine commutation)	8.57	12.86	17.14	N/Arms
Back EMF constant (phase to phase)	7*	10.6*	14.4*	V/m/s
Resistance @ 25 °C (phase to phase)	16.5	24.5	32.5	Ohm
Inductance @ 1 kHz (phase to phase)	7.3	11	14.6	mH
Electrical time constant	0.442	0.448	0.449	ms
Typical supply voltage of the servo drive	230	230	230	VAC
Max. DC bus voltage	560	560	560	VDC
Pole pitch	60	60	60	mm
Peak acceleration ⁽³⁾⁽⁶⁾	200	200	200	m/s ²
Maximum speed ⁽⁴⁾⁽⁶⁾	4	4	4	m/s

⁽¹⁾ S=series motor phases

⁽²⁾ at an ambient temperature of 40 °C

⁽³⁾ based on a 50 mm stroke, without payload

⁽⁴⁾ Based on triangular move over maximum stroke with nominal payload

⁽⁵⁾ Values specified are for machine integration with a heat-sink

⁽⁶⁾ The specifications and data may be subject to change depending of the load.

3.2.2. ETT025 Thermal Specifications

ETT025	S1	S2	S3	Unit
Maximum phase temperature	135	135	135	°C
Thermal resistance Rth _(phase-housing)	n.a.	n.a.	n.a.	°C/W
Thermal time constant	n.a.	n.a.	n.a.	s
<i>Without heatsink plate</i>				
Power dissipation at 25 °C ambient temperature	n.a.	n.a.	n.a.	Watt
Thermal resistance Rth _(housing-environment)	n.a.	n.a.	n.a.	°C/W
<i>With heatsink plate 25 x 25 x 2.5 cm ⁽⁷⁾</i>				
Power dissipation at 25 °C ambient temperature	n.a.	n.a.	n.a.	Watt
Thermal resistance Rth _(housing-environment)	n.a.	n.a.	n.a.	°C/W

⁽⁷⁾ Values specified are for machine integration with a heat-sink



3.2.3. Force / velocity profiles ETT025

Force/velocity profiles (with an operating voltage of 325 VDC., based on triangular move over 50 mm of stroke without payload)
S = series motor phases.

ETT025S1

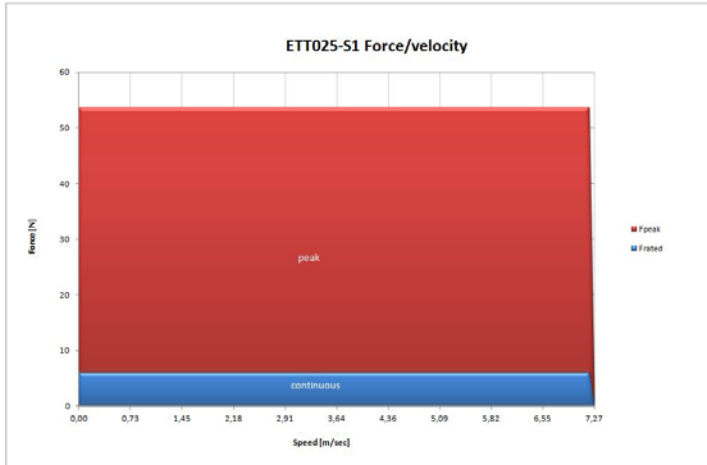

ETT025S2

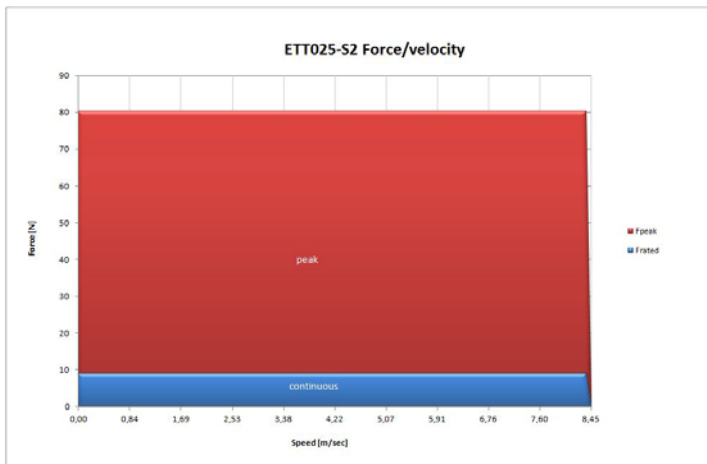

ETT025S1

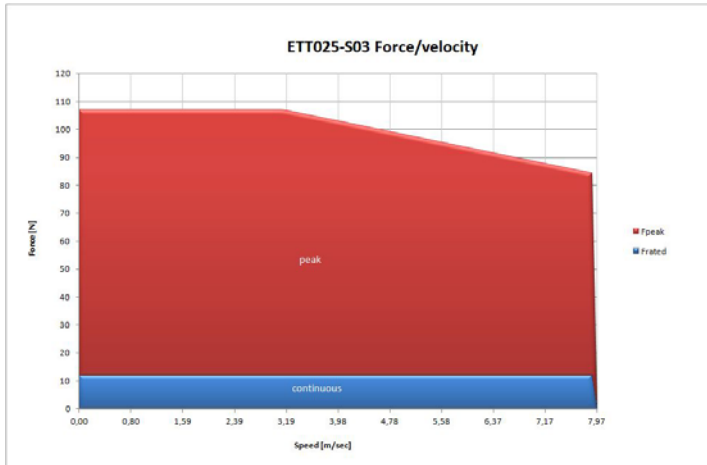



3.2.4. ETT032 Electric Specifications

ETT032	S1⁽¹⁾	S2⁽¹⁾	S3⁽¹⁾	Unit
Peak force ⁽²⁾ for 10 s	52	76	100	N
Peak current ⁽²⁾ for 10 s	2.72	2.48	2.46	A _{rms}
<i>Without heatsink plate</i>				
Continuous stall force ⁽²⁾	13	19	25	N
Continuous stall current ⁽²⁾	0.68	0.62	0.62	A _{rms}
<i>With heatsink plate 25 x 25 x 2.5 cm ⁽⁵⁾⁽⁶⁾</i>				
Continuous stall force ⁽²⁾	14	20	27	N
Continuous stall current ⁽²⁾	0.73	0.73	0.73	A _{rms}
Force constant (sine commutation)	19.12	30.65	40.32	N/Arms
Back EMF constant (phase to phase)	7	10.6	14.4	V/m/s
Resistance @ 25 °C (phase to phase)	29	43	56	Ohm
Inductance @ 1 kHz (phase to phase)	16	24	32	mH
Electrical time constant	0.551	0.558	0.571	ms
Typical supply voltage of the servo drive	230	230	230	VAC
Max. DC bus voltage	560	560	560	VDC
Pole pitch	60	60	60	mm
Peak acceleration ⁽³⁾⁽⁶⁾	200	200	200	m/s ²
Maximum speed ⁽⁴⁾⁽⁶⁾	4	4	4	m/s

⁽¹⁾ S=series motor phases

⁽²⁾ at an ambient temperature of 40°C

⁽³⁾ based on a 50 mm stroke, without payload

⁽⁴⁾ Based on triangular move over maximum stroke with nominal payload

⁽⁵⁾ Values specified are for machine integration with a heat-sink

⁽⁶⁾ The specifications and data may be subject to change depending of the load.

3.2.5. ETT032 Thermal Specifications

ETT032	S1	S2	S3	Unit
Maximum phase temperature	135	135	135	°C
Thermal resistance Rth _(phase-housing)	1.27	n.a.	1.11	°C/W
Thermal time constant	2006	n.a.	1990	s
<i>Without heatsink plate</i>				
Power dissipation at 25 °C ambient temperature	18.94	n.a.	31.38	Watt
Thermal resistance Rth _(housing-environment)	2.68	n.a.	1.95	°C/W
<i>With heatsink plate 25 x 25 x 2.5 cm ⁽⁷⁾</i>				
Power dissipation at 25 °C ambient temperature	n.a.	n.a.	n.a.	Watt
Thermal resistance Rth _(housing-environment)	n.a.	n.a.	n.a.	°C/W

⁽⁷⁾ Values specified are for machine integration with a heat-sink



3.2.6. Force / velocity profiles ETT032

Force/velocity profiles (with an operating voltage of 325 VDC, based on triangular move over 50 mm of stroke without payload)
S = series motor phases.

ETT032S1

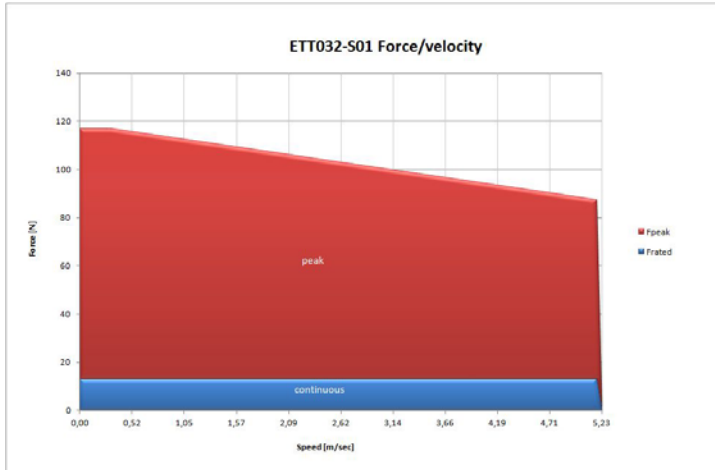

ETT032S2

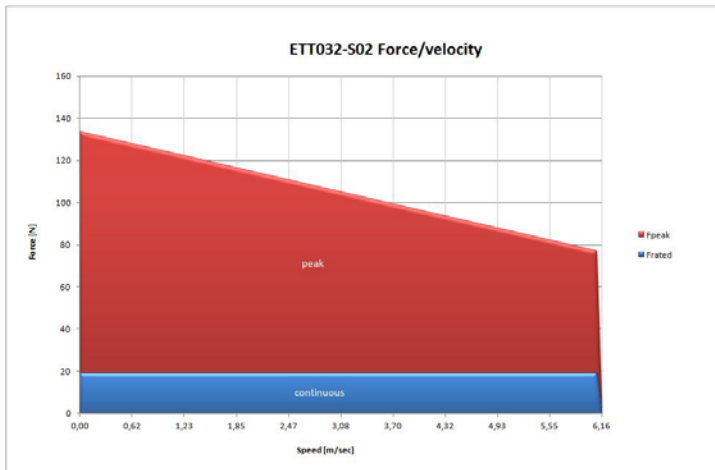

ETT032S3

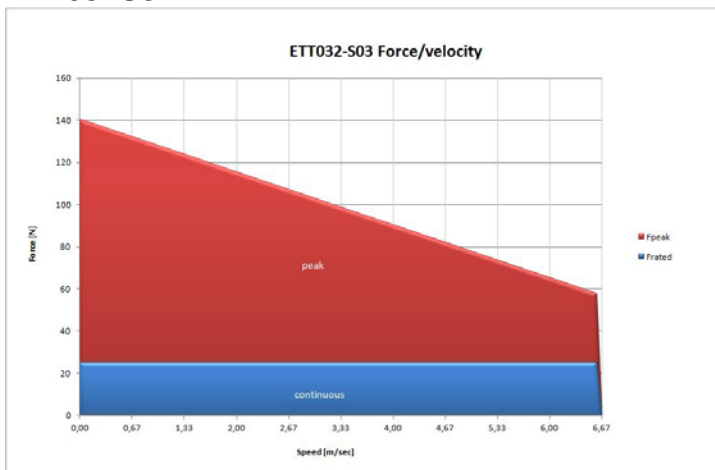



3.2.7. ETT050 Electric Specifications

ETT050	S1⁽¹⁾	S2⁽¹⁾	S3⁽¹⁾	Unit
Peak force ⁽²⁾ for 10 s	128	192	512	N
Peak current ⁽²⁾ for 10 s	2.48	2.48	2.48	A _{rms}
<i>Without heatsink plate</i>				
Continuous stall force ⁽²⁾	32	48	128	N
Continuous stall current ⁽²⁾	0.62	0.62	0.62	A _{rms}
<i>With heatsink plate 25 x 25 x 2.5 cm ⁽⁵⁾⁽⁶⁾</i>				
Continuous stall force ⁽²⁾	34	50	134	N
Continuous stall current ⁽²⁾	0.66	0.66	0.66	A _{rms}
Force constant (sine commutation)	51.61	77.42	206.45	N/Arms
Back EMF constant (phase to phase)	12.6	18.9	25.2	V/m/s
Resistance @ 25 °C (phase to phase)	44	66	44	Ohm
Inductance @ 1 kHz (phase to phase)	28	42	38	mH
Electrical time constant	0.636	0.636	0.864	ms
Typical supply voltage of the servo drive	230	230	230	VAC
Max. DC bus voltage	560	560	560	VDC
Pole pitch	60	60	60	mm
Peak acceleration ⁽³⁾⁽⁶⁾	200	200	200	m/s ²
Maximum speed ⁽⁴⁾⁽⁶⁾	4	4	4	m/s

⁽¹⁾ S=series motor phases

⁽²⁾ at an ambient temperature of 40°C

⁽³⁾ based on a 50 mm stroke, without payload

⁽⁴⁾ Based on triangular move over maximum stroke with nominal payload

⁽⁵⁾ Values specified are for machine integration with a heat-sink

⁽⁶⁾ The specifications and data may be subject to change depending of the load.

3.2.8. ETT050 Thermal Specifications

ETT050	S1	S2	S3	Unit
Maximum phase temperature	135	135	135	°C
Thermal resistance Rth _(phase-housing)	n.a.	n.a.	n.a.	°C/W
Thermal time constant	3577	2067	n.a.	s
<i>Without heatsink plate</i>				
Power dissipation at 25 °C ambient temperature	24.16	36.24	n.a.	Watt
Thermal resistance Rth _(housing-environment)	3.80	2.53	n.a.	°C/W
<i>With heatsink plate 25 x 25 x 2.5 cm ⁽⁷⁾</i>				
Power dissipation at 25 °C ambient temperature	n.a.	n.a.	n.a.	Watt
Thermal resistance Rth _(housing-environment)	n.a.	n.a.	n.a.	°C/W

⁽⁷⁾ Values specified are for machine integration with a heat-sink



3.2.9. Force / velocity profiles ETT050

Force/velocity profiles (with an operating voltage of 325 VDC., based on triangular move over 50 mm of stroke without payload)
S = series motor phases.

ETT050S1

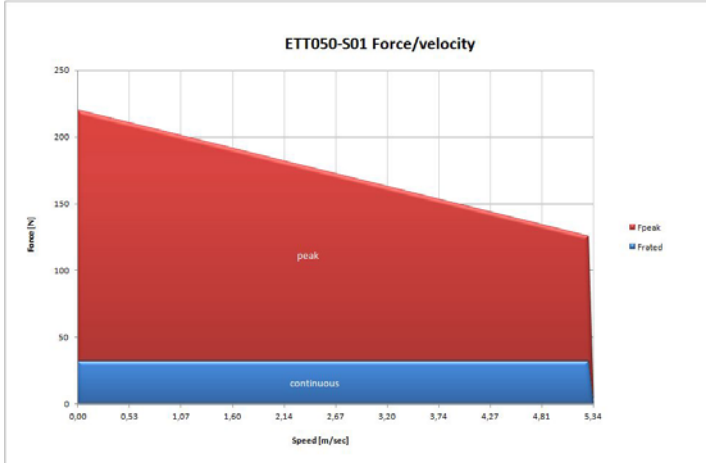

ETT050S2

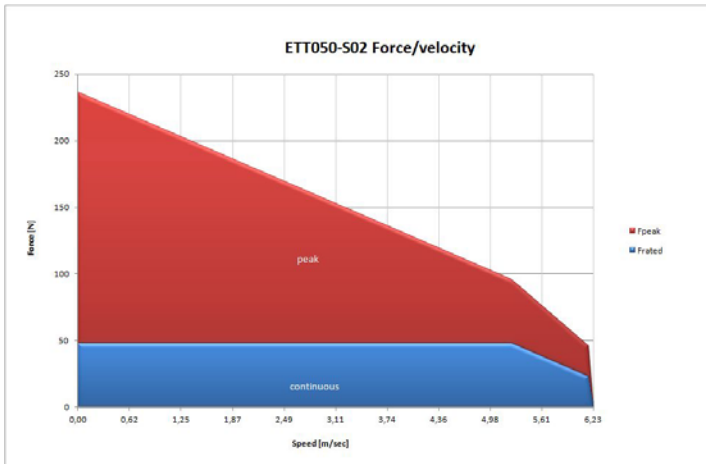

ETT050S3

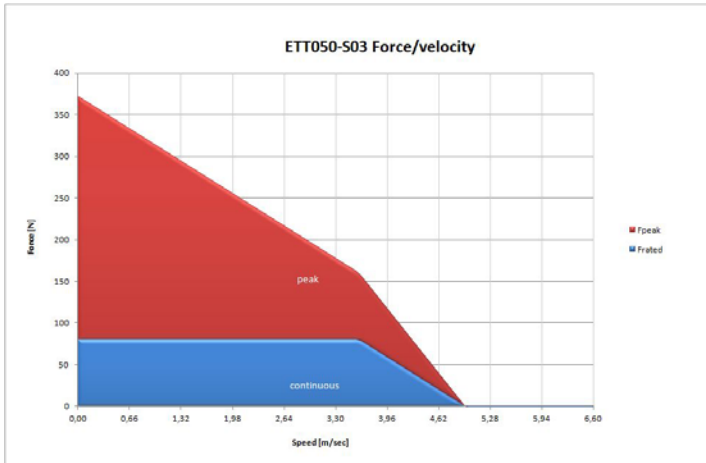

3.3. Dimension drawings

3.3.1. ETT025

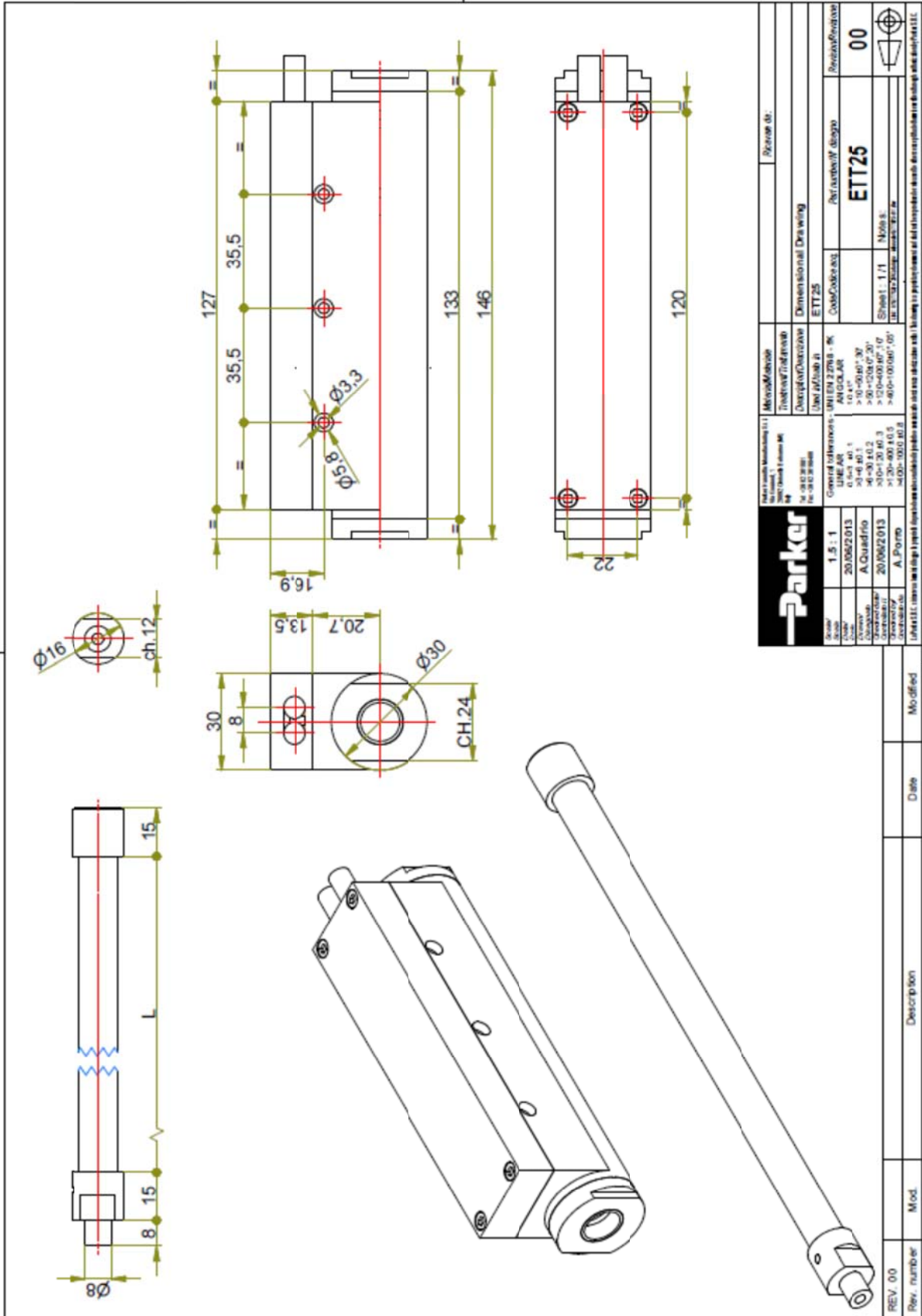

3.3.2. ETT032

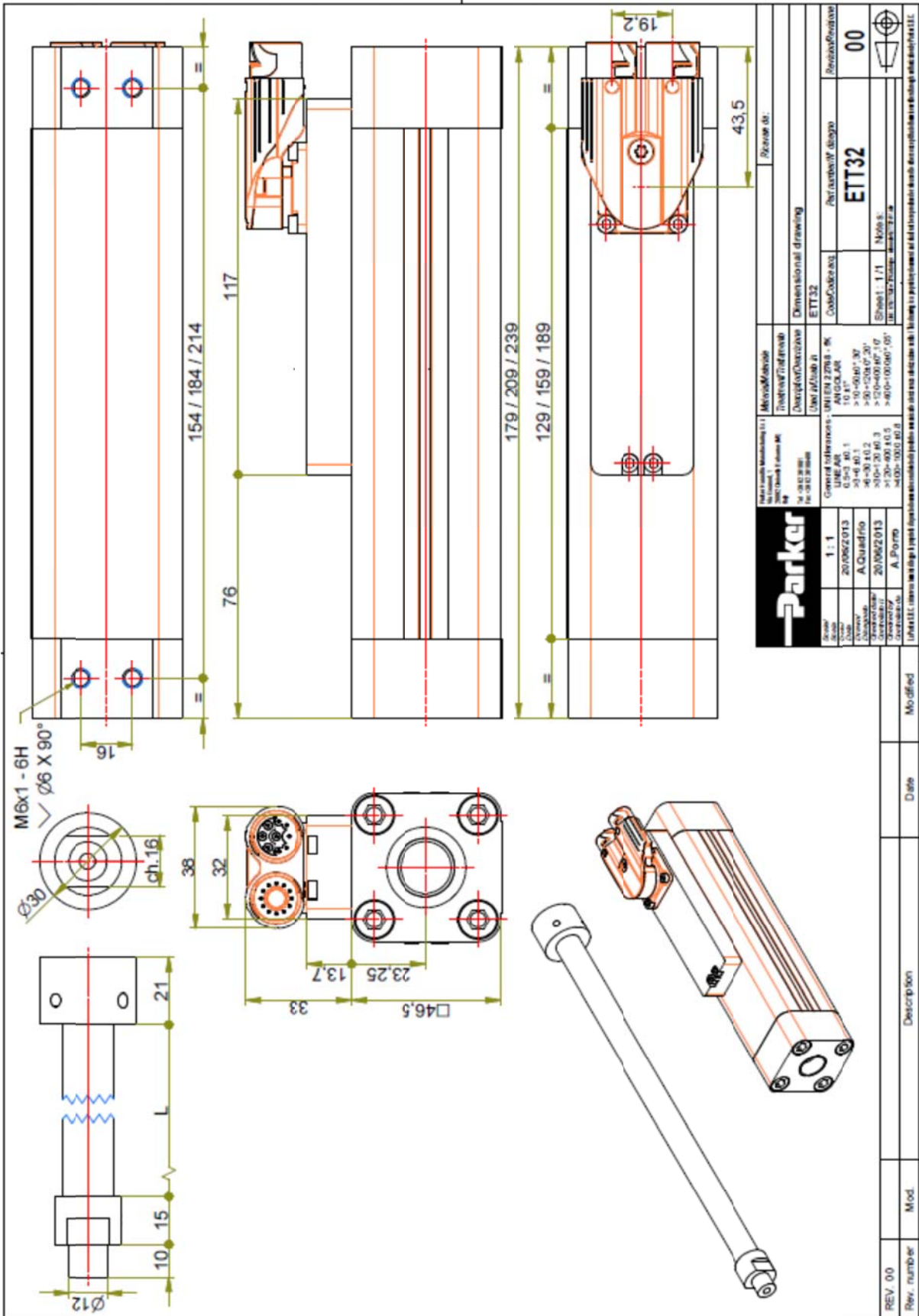

3.3.3. ETT050

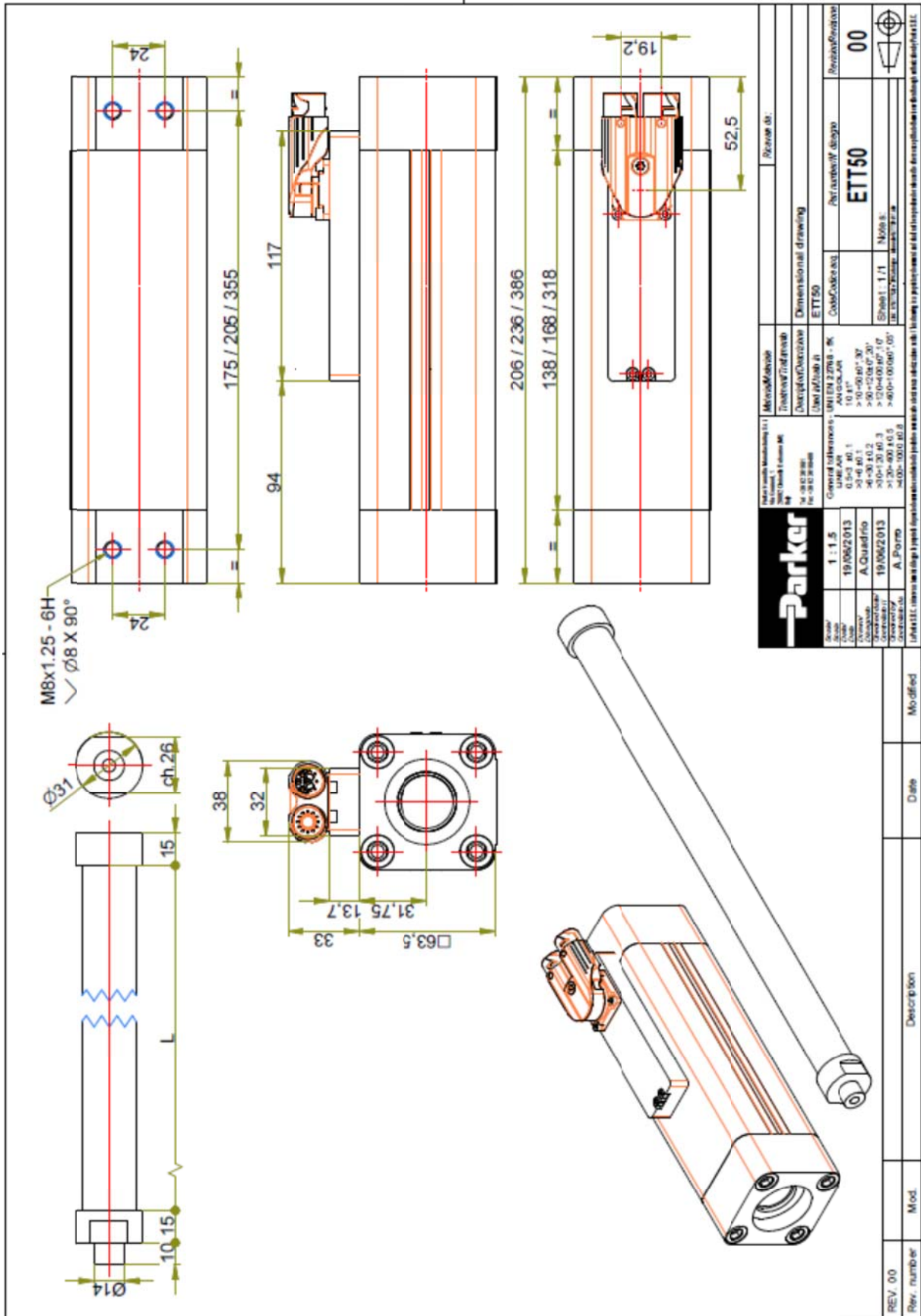

3.4. Motor Mounting

3.4.1. Motor mounting

3.4.1.1. Mobile ROD with stroke less of 200 mm

As the system is based on polymer plain bearings, the motor shaft can only sustain limited radial loads. Hence, coupling the shaft with the payload by spherical bearings, articulated joints or equivalent parts is recommended in order to only transmit the linear thrust and to compensate for any radial misalignment.

Note: Do not lubricate the shaft: polymer bearings are self-lubricating - additional lubricant would decrease their performance.

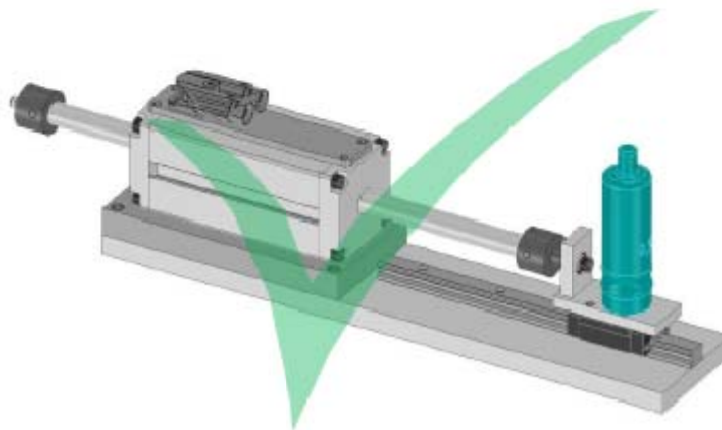
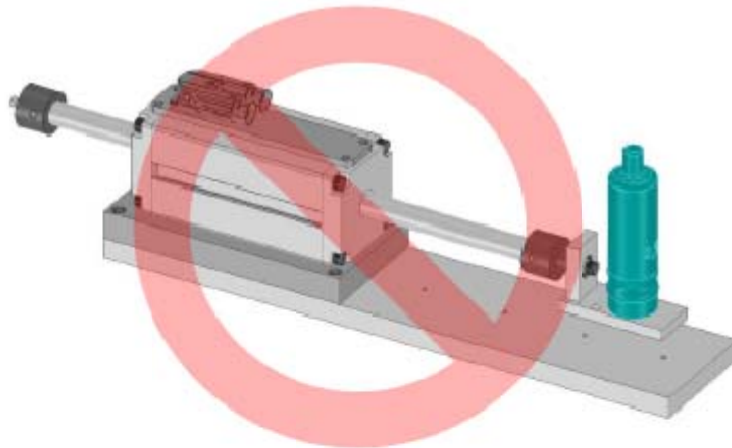

3.4.1.2. Mobile ROD with stroke more of 200 mm and small payloads

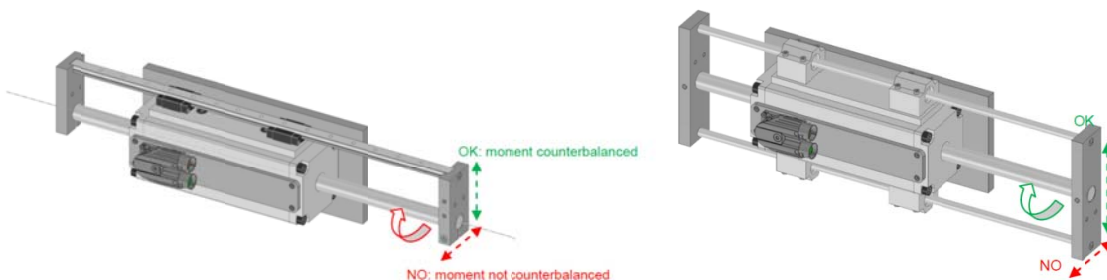

3.4.1.3. Moving shaft with strokes more than 200 mm and cantilever payloads

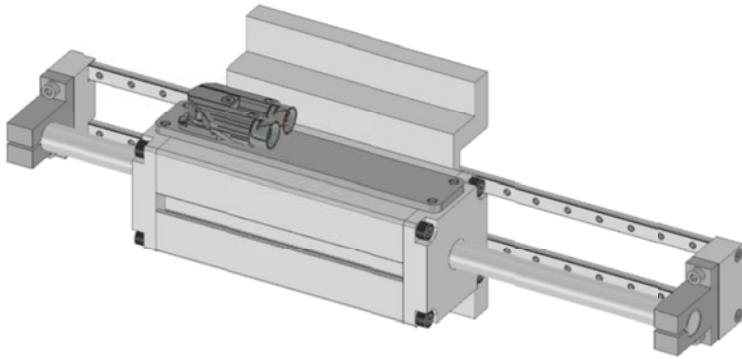

3.4.1.4. Moving truck

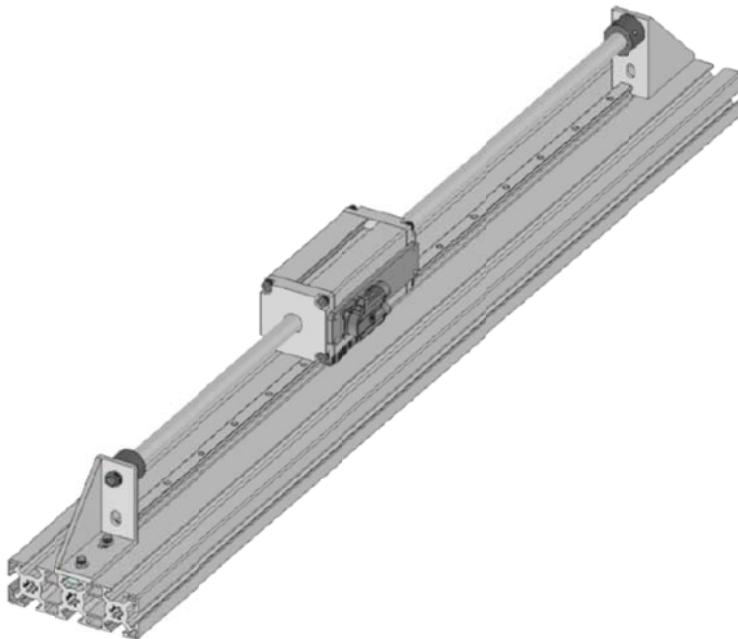



3.4.2. Accessories for mounting

3.4.2.1. Rear and Front Plate



Code 0112.918 for ETT032
Code 0122.918 for ETT050

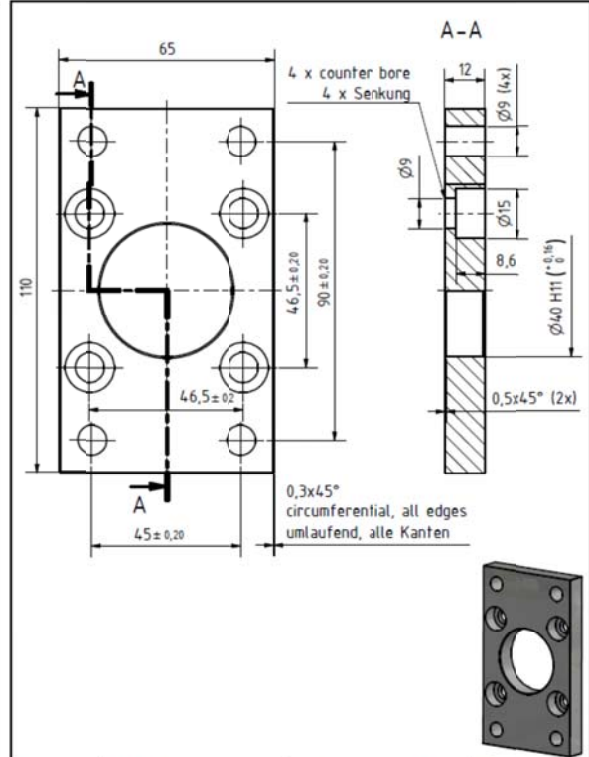
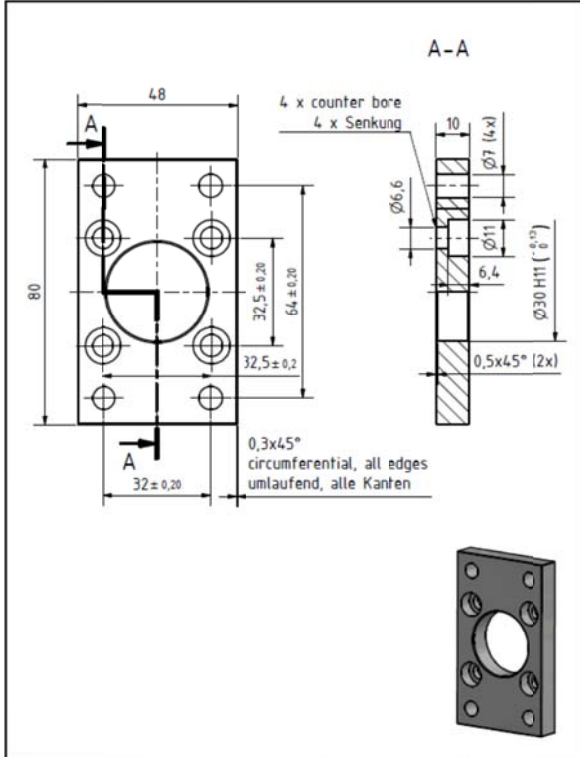

Edges:	RMS Finish: $\sqrt{Ra\ 6,3}$	Material: 1.4301(X5CrNi18-10)	Scale: 1:1
Part No.: 0111.064	Made From (Part No.):	Description: Rear- / Frontplate End- / Frontplatte	
Project Name: ETH032	Order Confirmation No.: 30890	Drawing No.: 0111 064 A	
Drawn: 03.03.2011 MS	Checked:	Sheet: 1	
Approved:	Revision State:	Drawing No.: 0111 064 A	
ECO No.:	Date:	Drawing No.: 0111 064 A	
Name:	Electromechanical Administration Europe	Drawing No.: 0111 064 A	
	EME	Drawing No.: 0111 064 A	
	D-77666 Offenburg	Drawing No.: 0111 064 A	
	0111064.idw	Drawing No.: 0111 064 A	
	0111064.ipf	Drawing No.: 0111 064 A	
	lthvntfuf	Drawing No.: 0111 064 A	

Edges:	RMS Finish: $\sqrt{Ra\ 6,3}$	Material: 1.4301(X5CrNi18-10)	Scale: 1:1
Part No.: 0121.064	Made From (Part No.):	Description: Rear- / Frontplate End- / Frontplatte	
Project Name: ETH050	Order Confirmation No.: 30890	Drawing No.: 0121 064 A	
Drawn: 03.03.2011 MS	Checked:	Sheet: 1	
Approved:	Revision State:	Drawing No.: 0121 064 A	
ECO No.:	Date:	Drawing No.: 0121 064 A	
Name:	Electromechanical Administration Europe	Drawing No.: 0121 064 A	
	EME	Drawing No.: 0121 064 A	
	D-77666 Offenburg	Drawing No.: 0121 064 A	
	0121064.idw	Drawing No.: 0121 064 A	
	0121064.ipf	Drawing No.: 0121 064 A	
	lthvntfuf	Drawing No.: 0121 064 A	

3.4.2.2. Stainless Brackets



Code 0112.916 for ETT032
Code 0122.916 for ETT050

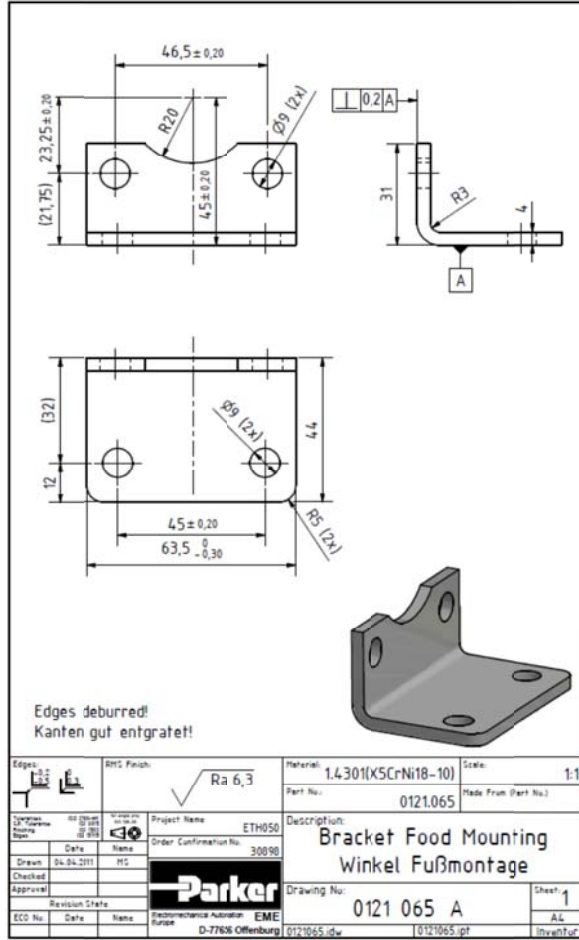
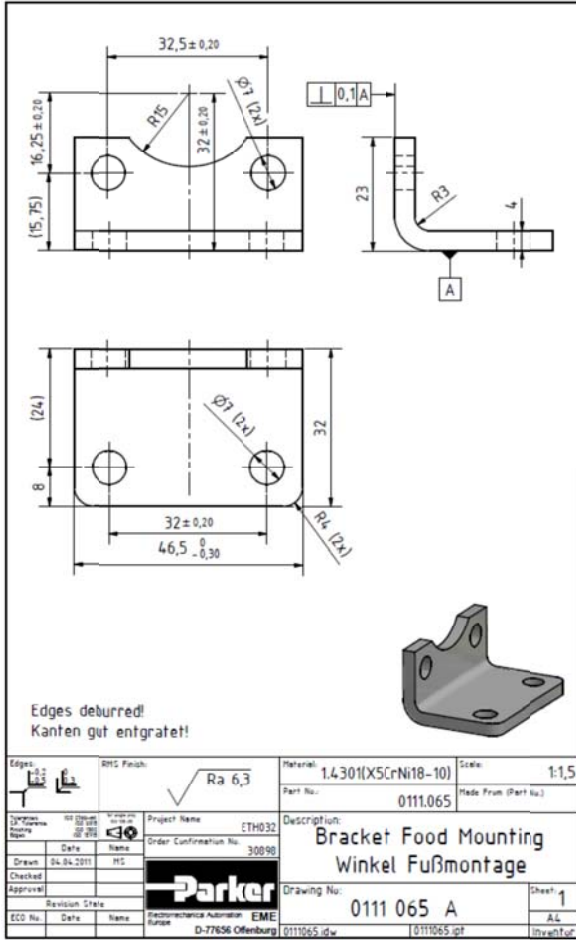

3.4.2.3. Mounting Flanges



Code 0112.917 for ETT032
Code 0122.917 for ETT050

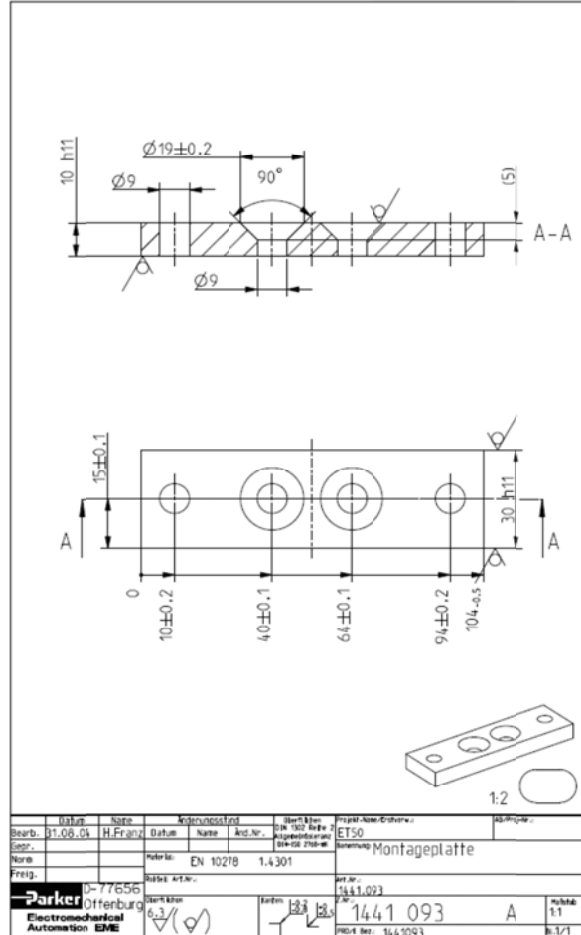
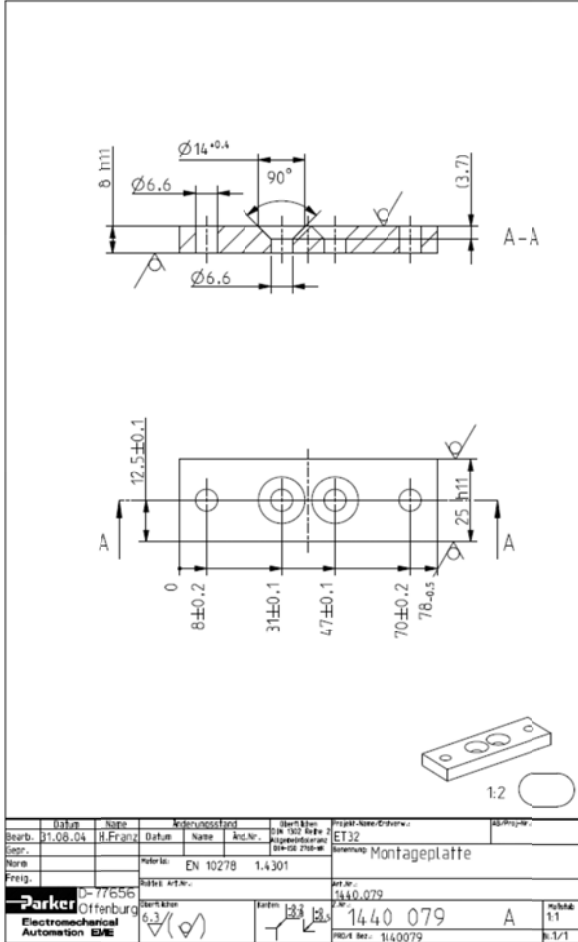

3.4.2.4. Spherical Rod eye



Plastic - igus®

Code KBRM-05 for ETT025

Code KBRM-06 for ETT032

Code KBRM-08 for ETT050

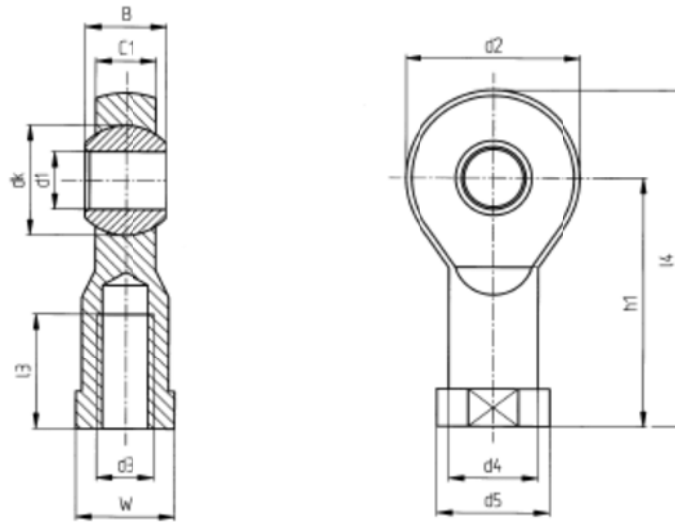

Part Number	D1	D2	D3	D4	D5	C1	B	H1	l3	l4	W	Max. Oscillation angle
K-BRM05	5	18	M05	9	12	6	8	27	10	36	SW09	30°
K-BRM06	6	20	M06	10	13	7	9	30	12	40	SW11	29°
K-BRM08	8	24	M08	13	16	9	12	36	16	48	SW14	25°

3.4.2.5. Rod Clevis



Plastic - igus®

Code GERM-05 for ETT025

Code GERM -06 for ETT032

Code GERM -08 for ETT050

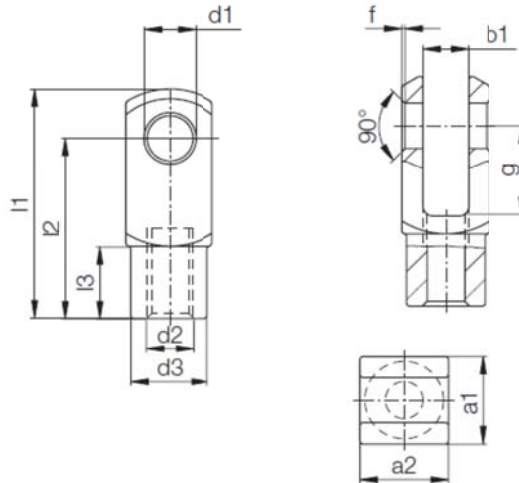

Part Number	d1	g	a1	a2	b1	d2	d3	f	l1	l2	l3
GERM-05	5	12	12	12	6	M05	10	0.5	31	24	9
GERM-06	6	12	12	12	6	M06	10	0.5	31	24	9
GERM-08	8	16	16	16	8	M08	14	0.5	42	32	12



Alignment Coupler R + W®

Code LK-70 for ETT025

Code LK-150 for ETT032

Code LK-300 for ETT050

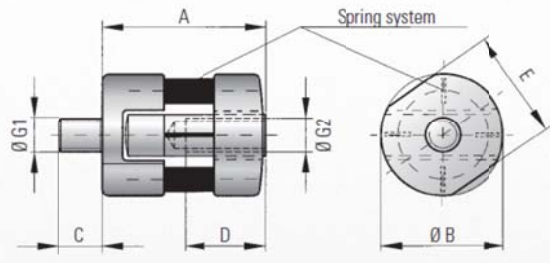

3.5. Cooling

In compliance with the IEC 60034-1 standards:

3.5.1. Natural cooled motor

The ambient air temperature shall not be less than **0 °C** and more than **40 °C**.

3.6. Thermal Protection

A KTY temperature sensor is built into the stator winding.

The thermal sensors, due to their thermal inertia, are unable to follow very fast winding temperature variations. They achieve their thermal steady state after a few minutes.

3.6.1. Temperature measurement with KTY sensors:

Motor temperature can be continuously monitored by the drive using a KTY 84-130 thermal sensor built in to the stator winding. KTY sensors are semiconductor sensors that change their resistance according to an approximately linear characteristic. The required temperature limits for alarm and tripping can be set in the drive.

The graph below shows KTY sensor resistance vs temperature, for a measuring current of 2 mA:

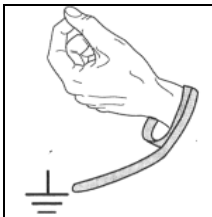
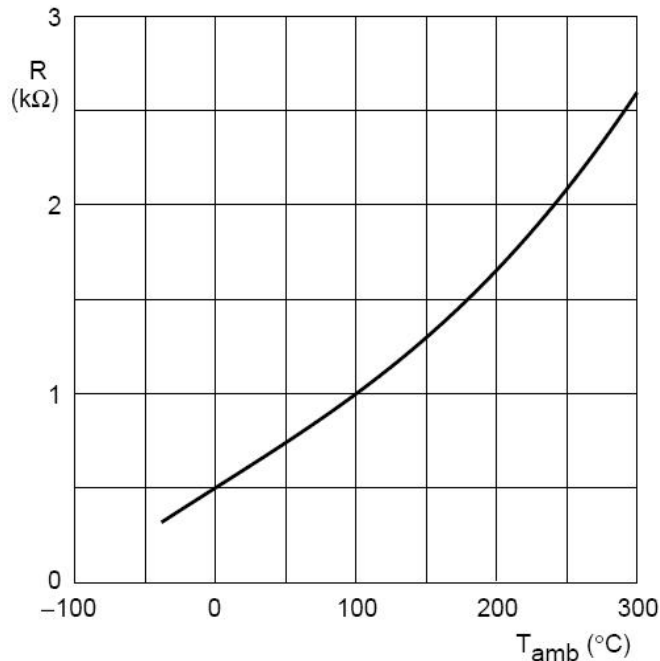

Warning: The KTY sensor is sensitive to electrostatic discharge. So, always wear an antistatic wrist strap during KTY handling.

	<p><u>Warning:</u> The KTY sensor is polarized. Do not invert the wires.</p>
---	--

	<p><u>Warning:</u> The KTY sensor is sensitive. Do not check resistance with an Ohmmeter or any measuring or testing device.</p>
---	--

3.7. Power Electrical Connections

3.7.1. Wires sizes

	<p>In every country, you must respect all the local electrical installation regulations and standards.</p>
---	--

	<p>Cable selection depends on the cable construction, so refer to the cable technical documentation to choose wire sizes</p>
---	--

	<p>Some drives have cable limitations or recommendations; please refer to the drive technical documentation for any further information.</p>
---	--

Cable selection

	<p>At standstill, the current must be limited at 80% of the low speed current I_o and the cable has to support peak current for a long period. So, if the motor works at standstill, the current to select wire size is $\sqrt{2} \times 0.8 I_o \cong 1,13 \times I_o$.</p>
---	--

Sizes for H07 RN-F cable, for a 3 cores in a cable tray at 30 °C max

Section [mm ²]	I_{max} [A _{rms}]
1.5	17
2.5	23
4	31

Conversion Awg / kcmil / mm²:

Awg	kcmil	mm ²
9	13.1	6.63
10	10.4	5.26
11	8.23	4.17
12	6.53	3.31
14	4.10	2.08
16	2.58	1.31
18	1.62	0.82
20	1.03	0.52
22	0.63	0.32
24	0.39	0.20
26	0.26	0.13



Motor cable length

For motors with low inductance values or low resistance winding values, the respective cable inductance, and/or resistance, particularly in the case of large cable lengths can greatly reduce the maximum speed of the motor.

Please contact PARKER for further information.



Caution: It might be necessary to fit a filter at the servo-drive output if the length of the cable exceeds 25 m. Consult us.

3.7.2. Mains supply connection diagrams

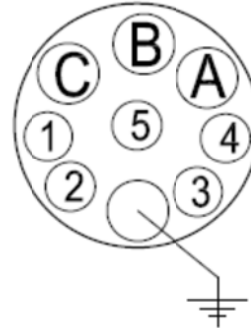

Feedback Connection		Power Connection	
Pin Number	Connection	Pin Number	Connection
1	Cos -	A	U
2	Cos +	B	W
3	N.C.	C	V
4	KTY84 -	PE	PE
5	KTY84 +	1	N.C.
6	N.C.	2	N.C.
7	Sin -	3	N.C.
8	Sin +	4	N.C.
9	N.C.	5	N.C.
10	+5V		
11	N.C.		
12	GND		

3.8. Feedback system

The position sensor outputs analog, differential sine and cosine signals for providing position feedback. Shown below are the relationships between motor phase back EMF and position sensor outputs for one direction of motion (as shown by arrows). It should be noted that +SIN or -SIN is always in phase with motor phase U. For the motion shown, -SIN is in phase with motor phase U. For motion in the opposing direction +SIN is in phase with motor phase U.

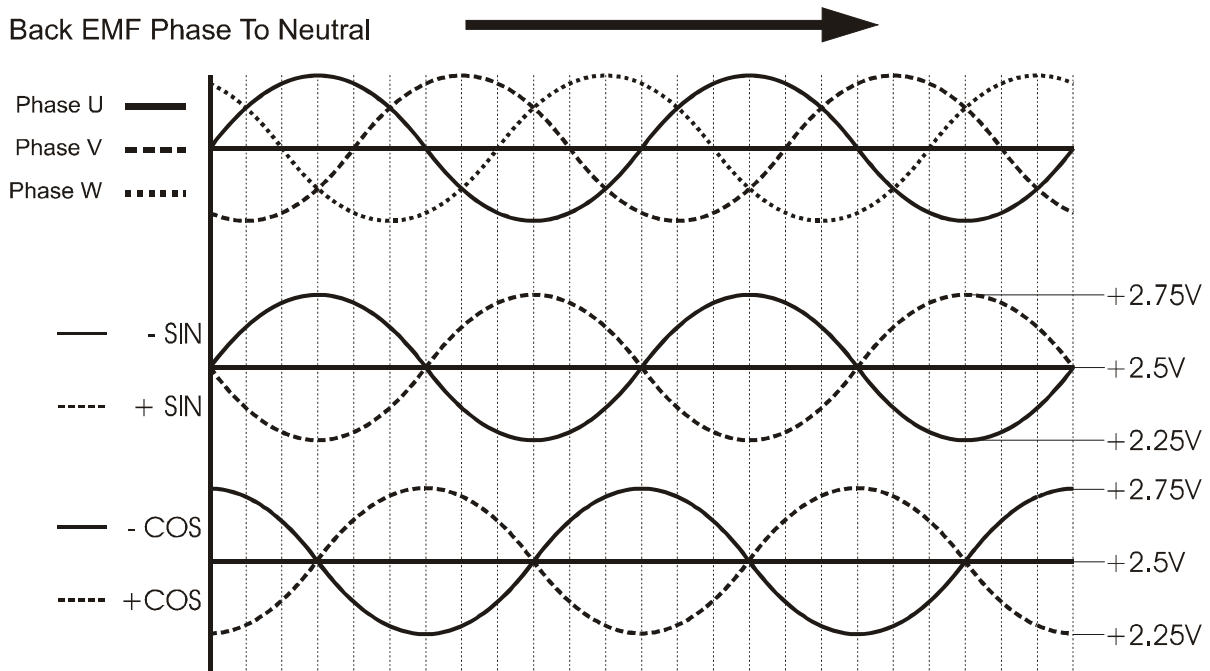

	ETT025	ETT032	ETT050	Unit
Pole pitch	60 NN	60	60	mm
Output current	50	50	50	mA
Supply voltage	5 ± 0.25	5 ± 0.25	5 ± 0.25	VDC
Supply current (output current =0)	40 ± 10%	40 ± 10%	40 ± 10%	mA
Repeatability ⁽²⁾ up to	50	50	50	µm

(2) Under constant operating conditions. Self-heating of the thrust rod by the motor will cause expansion in the thrust rod. In high duty applications (corresponding to an internal motor temperature of 80 °C) a 1 m thrust rod will expand typically by 250 µm.

3.8.1. Internal feedback option

Other types of position sensor are available; BISS, SSI, Incremental A/B can be used

BISS Absolute position sensor on BISS protocol

SSI Absolute position sensor on SSI protocol

Incremental TTL Incremental A/B TTL position sensor



3.8.2. External position sensor

For specific applications, different types of linear position sensors can be specified;
Example

TTK50-HXQ0K02	Hiperface linear feedback - Length of period 1 mm - Measured length 940 mm max - Accuracy $\pm 10\mu\text{m}$ (@20°C) - Repeat accuracy $< 5\mu\text{m}$ - Cable Length 2 m
MSK500010KE1/20LDI000505	Incremental linear feedback - Resolution up to 0,001 mm - Free programmable parameters (e.g. resolution) via optical interface - Status LEDs - Real-time data processing - Scale MB500 (linear) / MR500 (radial) - Fix and periodical reference signals

3.8.3. Cables

To connect ETT motors in the connector version to a PARKER drive : SLVDN or Compax3 you can use a complete cable with a part number from the table below.

3.8.3.1. Signal and Power cable

		ETTCAP	X	003	PM	-	Y1	SL	-	00
	Signal Cable Type									
ETTCAP	Power cable for ETT									
ETTCAS	Signal Cable for ETT – COS									
	Length (3 digits)									
	Example 003=3 m, 005=5 m, 010=10 m, etc..									
PM	Application type (2 digits)									
	Motor Connector (2 digits)									
Y1	Interconnectron Y-TECH Connector (ETT)									
X..	Special Execution									
	Drive Type (2 digits)									
SL	SLVDN Drive									
C3	C3 Drive									
	Option (2 digits)									
00	No Special Special Customer Drawing									

Example:

Power Cable ETTCAPx002PM-Y1SL-00 cable for ETT and SLVDN length 3 m

Signal Cable ETTCASx002PM-Y1SL-00 cable for ETT and SLVDN length 3 m



All cables are available with the follow lengths: 3 m – 5 m – 7 m – 10 m – 15 m -20 m.

4. COMMISSIONING, USE AND MAINTENANCE

4.1. Instructions for commissioning, use and maintenance

4.1.1. Equipment delivery

All servo motors are strictly controlled during manufacturing, before shipping. Upon receipt, it is necessary to verify the motor condition and confirm it has not been damaged in transit.

	<p><u>Warning:</u> In case of damaged material during transit, the recipient must immediately notify the carrier through a registered mail within 24 h..</p>
	<p>Forbidden for persons with heart pace makers Persons with heart pace makers are not allowed to handle or work with this product. Keep the necessary safety distance.</p>
	<p>Beware of the magnetic field The magnetic rod does contain strong magnets and exerts a strong pull on ferromagnetic objects. Non-compliance with the safety instructions may result in damages to computer drives and credit cards.</p>

- Check the packaging for damages.
- Remove the packaging.
Do not discard the packaging; it is strongly recommended to use the original packaging material for return deliveries.
- Depending on the storage location, metal surfaces may have a temperature of 0°C or below. Please provide appropriate worker protection (e.g. protective gloves).
- Please ensure that the consignment does correspond to your order.
- Check the product for damages. Do never use a device which seems damaged.
- Please read the installation manual carefully before installing or commissioning the device.

4.1.2. Handling

	<p>Heavy object Heavy objects should not be lifted by a single person.</p>
---	---

4.1.3. Storage

Before being mounted, the motor has to be stored in a dry place, without rapid or important temperature variations in order to avoid condensation.
During storage, the ambient temperature must be kept between -20 and +60 °C.

If the servo motor has to be stored for a long time, verify that the rod, feet and the flange are coated with corrosion proof product.

4.2. Installation

4.2.1. Mounting

The ETT comprises the primary element with an integrated polymer sliding bearing and the magnet rod.

The integral bearing provides guidance for the movement of the magnet rod. It is not intended to compensate lateral forces. If lateral forces are likely to occur in your application, you must provide for an additional bearing.

The magnet rod of the ETT has an external thread on one end and on the opposite end an internal thread. This permits the use of a wide range of ETT accessories, and Industry standard DIN/ISO6431 components. A locking ring at each end of the magnet rod fixes it within the primary element. The locking rings are not designed as limit stops and are not suitable to protect against exceeding the travel path. It is the responsibility of the user to prevent the magnet rod from being pushed out of the primary element.

4.2.2. Preparation

Once the motor is installed, it must be possible to access the wiring, and read the manufacturer's plate. Air must be able to circulate around the motor for cooling purposes.

Clean the shaft using a cloth soaked in white spirit or alcohol. Ensure that the cleaning solution does not get on to the bush bearings.

The motor must be in a horizontal position during cleaning or running.







Caution: Do not step on the motor, the connector or cables.



Caution: Always bear in mind that some parts of the surface of the motor can reach temperatures exceeding 100 °C.





4.3. Electrical connections

	<p><u>Danger:</u> Check that the power to the electrical cabinet is off prior to making any connections.</p>
	<p><u>Caution:</u> The wiring must comply with the drive commissioning manual and with recommended cables.</p>
	<p><u>Danger:</u> The motor must be earthed by connecting to an unpainted section of the motor.</p>
	<p><u>Caution:</u> After 15 days, check all tightening torques on cable connections.</p>

4.3.1. Cable connection

Please, read §3.7 "Electrical connection" for information about cable connection
A lot of information is already available in the drive documentation.

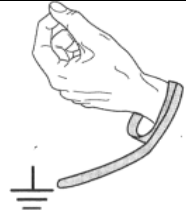
4.3.2. Encoder cable handling

	<p><u>Danger:</u> before any intervention the drive must be stopped in accordance with the procedure.</p>
	<p><u>Caution:</u> It is forbidden to disconnect the Encoder cable under voltage (high risk of damage and sensor destruction).</p>
	<p><u>Warning:</u> Always wear an antistatic wrist strap during encoder handling.</p>
	<p><u>Warning:</u> Do not touch encoder contacts (risk of damage due to electrostatic discharges ESD).</p>

4.4. Maintenance Operations

4.4.1. Summary maintenance operations

	<p>Generality <u>DANGER:</u> The installation, commission and maintenance operations must be performed by qualified personnel, in conjunction with this documentation.</p> <p>The qualified personnel must know the safety (C18510 authorization, standard VDE 0105 or IEC 0364) and local regulations.</p> <p>They must be authorized to install, commission and operate in accordance with established practices and standards.</p> <p>Please contact PARKER for technical assistance.</p>
---	--

	<p><u>Danger:</u> before any intervention the motor must be disconnected from the power supply. Due to the permanent magnets, a voltage is generated at the terminals when the motor shaft is moved</p>
---	--

Depending on the type of application you must inspect the motor and lubrication of the rod according to the follow table:

For a standard application:

Operation	Periodicity
Clean the motor (cleaning fluids without solvents, kerosene or similar)	Comissioning and Every year
Motor inspection (vibration changes, temperature changes, tightening torques on all scews)	Comissioning and Every 3 months
Lubrication	Comissioning and Every 3 months



4.5. Troubleshooting

Check, if the problem you face is listed in the table below. If you cannot solve the problem with the aid of this table, please contact our service department.

Error	possible cause	Action
Primary element / magnet rod does not move and does not develop any force	Drive without supply voltage. Motor phases not connected. Overtemperature sensor not connected. Switched-off by overtemperature.	Connect supply voltage for drive. Check: Connections of the motor phases to drive. Check: Connections of the overtemperature sensor to drive. Allow primary element to cool off.
Primary element / magnet rod does not move but develops holding force or is energized	One or several motor phases not correctly connected or not connected at all. One or several sensor connections faulty or not connected at all. Primary element / magnet rod blocked mechanically.	Check: Connections of the motor phases to drive. Check: Connections of the position sensor to drive. Check: if primary element / magnet rod can be moved easily.
Primary element / magnet rod does move jerkily	Wrong motor pole pitch set or wrong Offset between position sensor and EMF.	Check: Setup of drive or controller.
Primary element / magnet rod moves in the wrong direction	One or several sensor connections or motor phases faulty or not connected at all.	Check: Correct connection of position sensor and motor phases.

Please Note: Use the original packaging material for return shipments.



PARKER HANNIFIN MANUFACTURING SRL
Electromechanical Division Europe (EME)

Via C. Gounod, 1

I-20092 Cinisello Balsamo (MI)

Tel : +39 02 361081

Fax : +39 02 36108400

www.parker.com/eme

em-motion@parker.com



aerospace
climate control
electromechanical
filtration
fluid & gas handling
hydraulics
pneumatics
process control
sealing & shielding

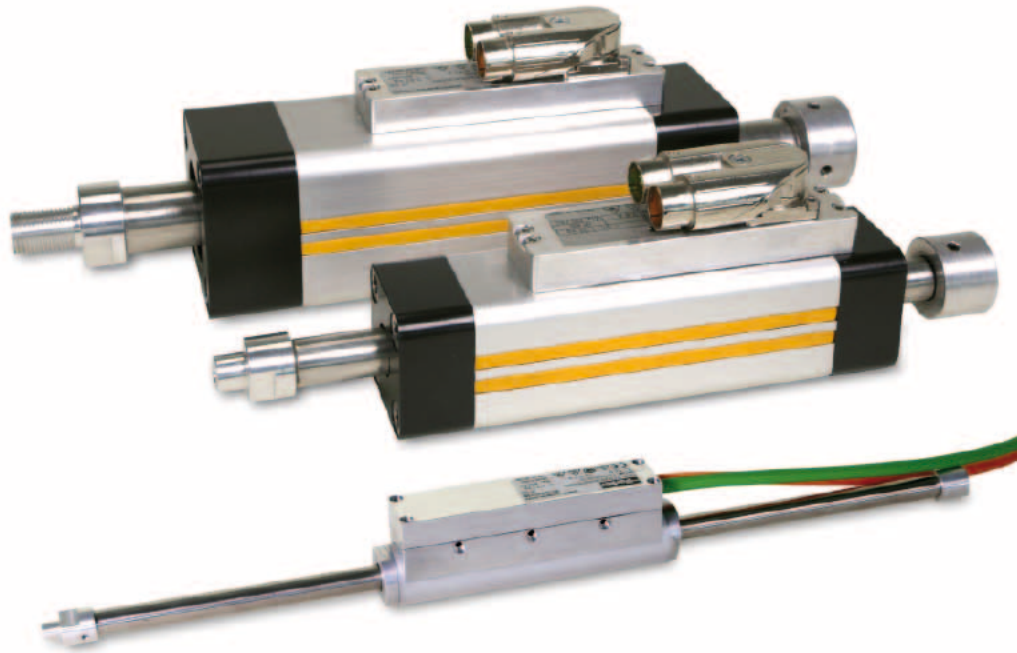

ETT - Electric Tubular Motor

Linear Handling and Pick & Place Applications

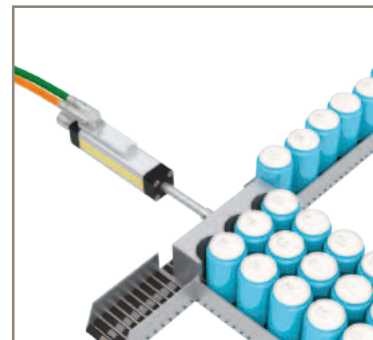

ENGINEERING YOUR SUCCESS.



WARNING – USER RESPONSIBILITY

FAILURE OR IMPROPER SELECTION OR IMPROPER USE OF THE PRODUCTS DESCRIBED HEREIN OR RELATED ITEMS CAN CAUSE DEATH, PERSONAL INJURY AND PROPERTY DAMAGE.

- This document and other information from Parker-Hannifin Corporation, its subsidiaries and authorized distributors provide product or system options for further investigation by users having technical expertise.
- The user, through its own analysis and testing, is solely responsible for making the final selection of the system and components and assuring that all performance, endurance, maintenance, safety and warning requirements of the application are met. The user must analyze all aspects of the application, follow applicable industry standards, and follow the information concerning the product in the current product catalog and in any other materials provided from Parker or its subsidiaries or authorized distributors.
- To the extent that Parker or its subsidiaries or authorized distributors provide component or system options based upon data or specifications provided by the user, the user is responsible for determining that such data and specifications are suitable and sufficient for all applications and reasonably foreseeable uses of the components or systems.

Overview	5
Technical Characteristics.....	6
Technical Data.....	6
Standards and Conformance	7
Speed Force Curves	8
Associated Drives.....	9
Dimensions	10
Layout and Connectors ETT032 & ETT050	11
Accessories and Options	12
Mounting Methods	12
Cylinder Rod Version.....	14
Feedback.....	15
Order Code.....	16
ETT Electric Tubular Motor (Complete Unit)	16
ETT - Motor and Signal Cable.....	16
ETT Electric Tubular Motor (Rod only).....	17
ETT Electric Tubular Motor (Coil only).....	17
ETT - Length of Rod / Table of Stroke.....	18

Parker Hannifin

The global leader in motion and control technologies

A world class player on a local stage

Global Product Design

Parker Hannifin has more than 40 years experience in the design and manufacturing of drives, controls, motors and mechanical products. With dedicated global product development teams, Parker draws on industry-leading technological leadership and experience from engineering teams in Europe, North America and Asia.

Local Application Expertise

Parker has local engineering resources committed to adapting and applying our current products and technologies to best fit our customers' needs.

Manufacturing to Meet Our Customers' Needs

Parker is committed to meeting the increasing service demands that our customers require to succeed in the global industrial market. Parker's manufacturing teams seek continuous improvement through the implementation of lean manufacturing methods throughout the process. We measure ourselves on meeting our customers' expectations of quality and delivery, not just our own. In order to meet these expectations, Parker operates and continues to invest in our manufacturing facilities in Europe, North America and Asia.

Electromechanical Worldwide Manufacturing Locations

Europe

Littlehampton, United Kingdom
Dijon, France
Offenburg, Germany
Filderstadt, Germany
Milan, Italy

Asia

Wuxi, China
Chennai, India

North America

Rohnert Park, California
Irwin, Pennsylvania
Charlotte, North Carolina
New Ulm, Minnesota



Offenburg, Germany

Local Manufacturing and Support in Europe

Parker provides sales assistance and local technical support through a network of dedicated sales teams and authorized technical distributors throughout Europe.

For contact information, please refer to the Sales Offices on the back cover of this document or visit www.parker.com



Milan, Italy



Littlehampton, UK

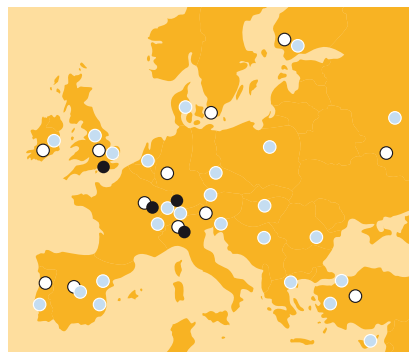

- Electromechanical Manufacturing
- Parker Sales Offices
- Distributors



Dijon, France

Electric Tubular Motor - ETT

Overview

Description

ETT is a direct thrust linear motor actuator, ideally suited for all kinds of linear handling and pick & place applications. It is a cost-effective and energy-efficient alternative to pneumatic cylinders in applications that demand greater flexibility and control.

The ETT's linear motion is directly generated without the need for mechanical transmission elements like ball screws, toothed belts and gearboxes. The tubular motor has two main components; the rod (shaft) and the stator with integrated feedback (body). The shaft is made of a stainless steel tube with built in neodymium magnets, that thanks to their high performance, are able to deliver impressive thrust values up to 512 N. The main body comprises the stator winding, the feedback electronics and high performance bearings. A major benefit of the ETT design is that long and/or heavy duty cycles are possible without the need of additional cooling. The IP67 protection class allows the ETT tubular motor to be used in harsh environmental conditions.

Features

- Ultra dynamic linear motion and position control capabilities
- Ideally suited for pneumatic substitution where greater position control capabilities are required
- Three lengths and three sizes meeting the requirements of the pneumatic ISO flange standard (DIN ISO 15552:2005-12) for simplified mechanical integration
- Swivelling electrical connectors and extensive accessory options allow flexible mounting
- Reduced mechanical complexity delivers high energy efficiency and reduces maintenance
- AISI304 stainless steel shaft allows it's use in "clean" environments
- High thermal efficiency improves reliability and increases mechanical life
- Wide choice of rod end mounting options, including swivel rod eye, increases flexibility

Application

- Food, Pharmaceutical & Beverage
- Packaging Machines
- Material Handling
- Factory Automation

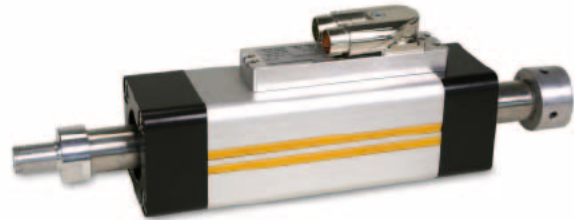

Technical Characteristics - Overview

Motor type	Linear tubular servo motor
Rod	AISI304 (stainless steel)
Rated force	6 ... 128 N
Peak force	24 ... 512 N
Speed range	up to 4 m/s
Acceleration range	200 m/s ²
Mounting	Screw fixed
Shaft end	With screw fix external thread (standard) Other (option)
Cooling	Natural ventilation
Protection level (IEC60034-5)	IP67
Feedback sensor	1 Vpp Sine/Cosine encoder
Thermal protection	KTY
Marking	CE
Voltage supply	230 VAC other voltage on request
Temperature class	Class F
Connections	Connectors for ETT032/050 Flying cables for ETT025
Accuracy	±0.05 mm

Technical Characteristics

Technical Data

ETT025

ETT025		ETT025S1	ETT025S2	ETT025S3
	Unit			
Power supply 230 VAC				
Effective stroke	[mm]	30 ... 360		
Rated force	[N]	6	9	12
Peak force for 10 s ¹⁾	[N]	24	36	48
Maximum speed ²⁾	[m/s]	4		
Peak acceleration ³⁾	[m/s ²]	200		
Actuator length	[mm]	162		
Slider length w/o stop	[mm]	215 ... 545		
Slider weight	[kg]	0.224 ... 0.618		
Slider diameter	[mm]	12		
Pole pitch	[mm]	60		
Force constant	[N/A]	8.57	12.86	17.14
Back EMF	[V/(m/s)]	n.a		
Phase resistance	[ohm]	16.5	24.5	32.5
Phase inductance	[mH]	7.3	11	14.6
Position repeatability	[mm]	± 0.05		

¹⁾ Data valid at an ambient temperature of 40 °C

²⁾ Based on triangular move over maximum stroke with nominal payload

³⁾ Based on a 50 mm stroke, without payload

ETT032

ETT032		ETT032S1	ETT032S2	ETT032S3
	Unit			
Power supply 230 VAC				
Effective stroke	[mm]	30 ... 660	30 ... 630	30 ... 600
Rated force	[N]	13	19	25
Peak force for 10 s ¹⁾	[N]	52	76	100
Maximum speed ²⁾	[m/s]	4		
Peak acceleration ³⁾	[m/s ²]	200		
Actuator length	[mm]	179	209	239
Slider length w/o stop	[mm]	221 ... 851		
Slider weight	[kg]	0.389 ... 1.63		
Slider diameter	[mm]	16		
Pole pitch	[mm]	60		
Force constant	[N/A]	19.12	30.65	40.32
Back EMF	[V/(m/s)]	7	10.6	14.4
Phase resistance	[ohm]	29	43	56
Phase inductance	[mH]	16	24	32
Position repeatability	[mm]	± 0.05		

¹⁾ Data valid at an ambient temperature of 40 °C

²⁾ Based on triangular move over maximum stroke with nominal payload

³⁾ Based on a 50 mm stroke, without payload

ETT050

ETT050		ETT050S1	ETT050S2	ETT050S3
	Unit			
Power supply 230 VAC				
Effective stroke	[mm]	30 ... 720	30 ... 690	30 ... 540
Rated force	[N]	32	48	128
Peak force for 10 s ¹⁾	[N]	128	192	512
Maximum speed ²⁾	[m/s]	4		
Peak acceleration ³⁾	[m/s ²]	200		
Actuator length	[mm]	206	236	386
Slider length w/o stop	[mm]	254 ... 944		
Slider weight	[kg]	0.56 ... 2.12		
Slider diameter	[mm]	25		
Pole pitch	[mm]	60		
Force constant	[N/A]	51.61	77.42	206.45
Back EMF	[V/(m/s)]	12.6	18.9	25.2
Phase resistance	[ohm]	44	66	44
Phase inductance	[mH]	28	42	38
Position repeatability	[mm]	± 0.05		

¹⁾ Data valid at an ambient temperature of 40 °C

²⁾ Based on triangular move over maximum stroke with nominal payload

³⁾ Based on a 50 mm stroke, without payload

Standards and Conformance

Low Voltage Directive	<ul style="list-style-type: none"> • 2006/95/EC
EMC Directive	<ul style="list-style-type: none"> • 2004/108/EC
Generic standard - Emission standard for industrial environments	<ul style="list-style-type: none"> • CEI EN 61000-6-4:2007
Generic standard - Immunity for industrial environments	<ul style="list-style-type: none"> • CEI EN 61000-6-2:2006

Marked 

Speed Force Curves ¹⁾

ETT025-S1 force / velocity curves

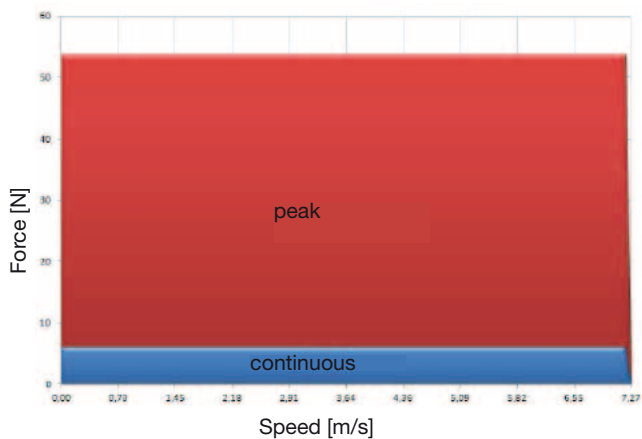

ETT025-S2 force / velocity curves

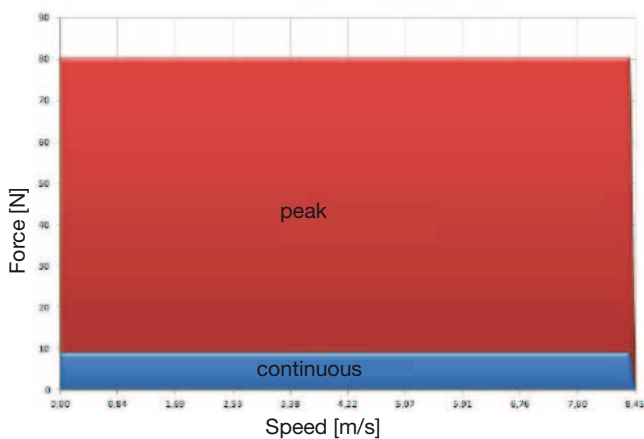

ETT025-S3 force / velocity curves

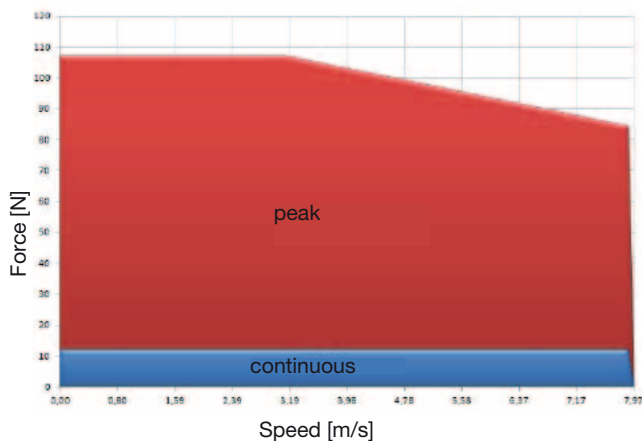

ETT032-S1 force / velocity curves

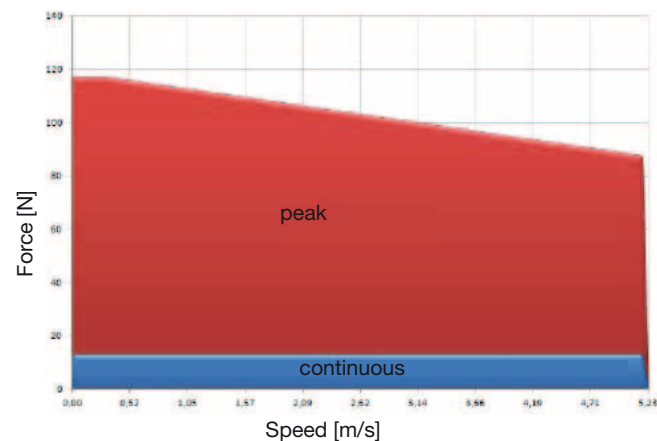

ETT032-S2 force / velocity curves

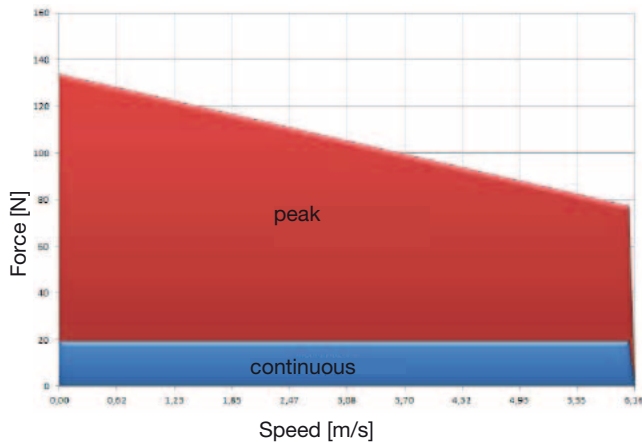

ETT032-S3 force / velocity curves

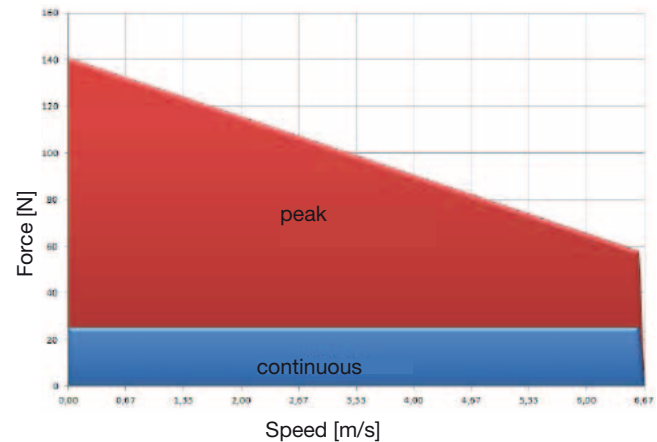

¹⁾ Based on triangular move over maximum stroke without payload

Speed Force Curves ¹⁾

ETT050-S1 force / velocity curves

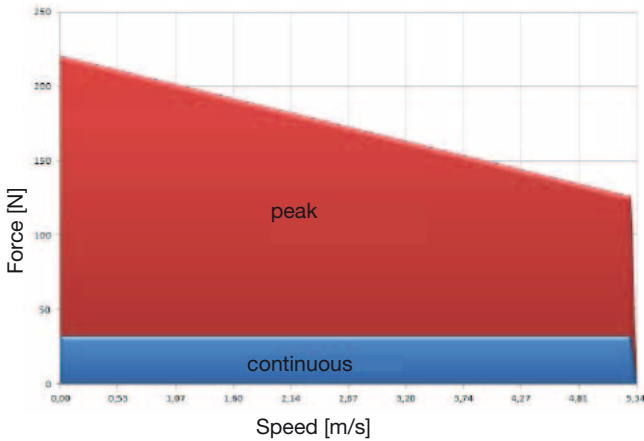

ETT050-S2 force / velocity curves

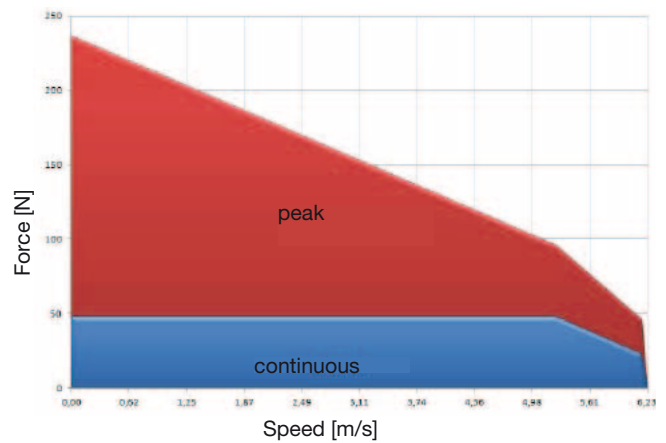

ETT050-S3 force / velocity curves

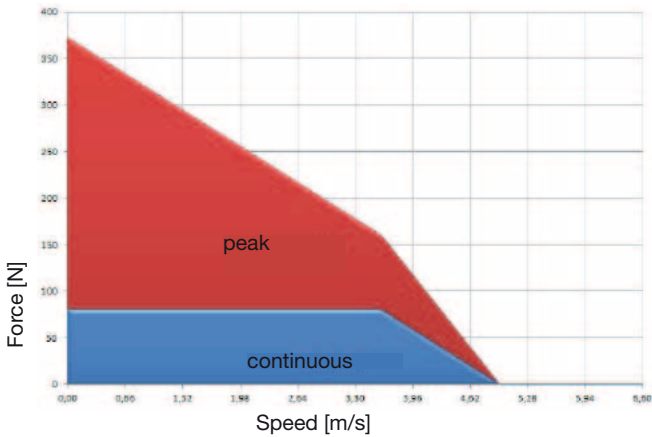

¹⁾ Based on triangular move over maximum stroke without payload

Associated Drives

Parker can also offer suitable servo drives with a variety of different technology functions and communication options for use with the ETT series.

ETT Type	Continuous current [A]	SLVD-N	Compax3
ETT025S1	0.7	SLVD2N...	C3S025V2...
ETT025S2	0.7		
ETT025S3	0.7		
ETT032S1	0.68		
ETT032S2	0.62		
ETT032S3	0.62		
ETT050S1	0.62		
ETT050S2	0.62		
ETT050S3	0.62		

Dimensions

ETT025

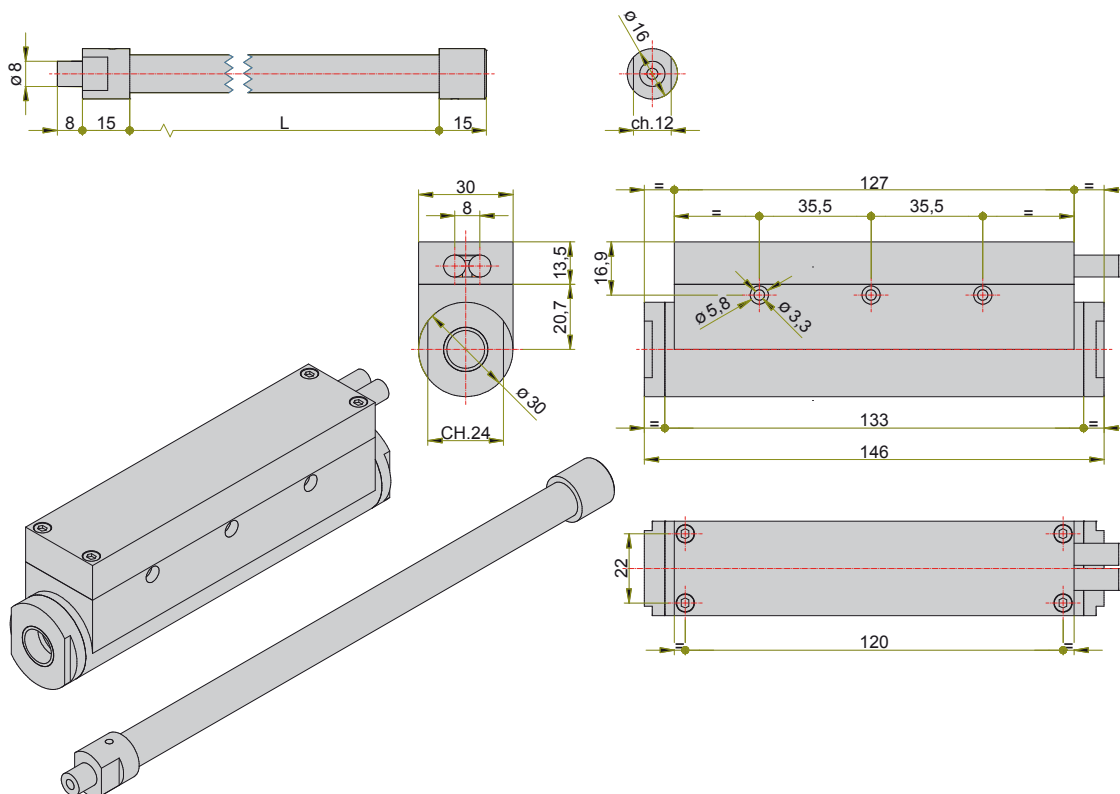

ETT032

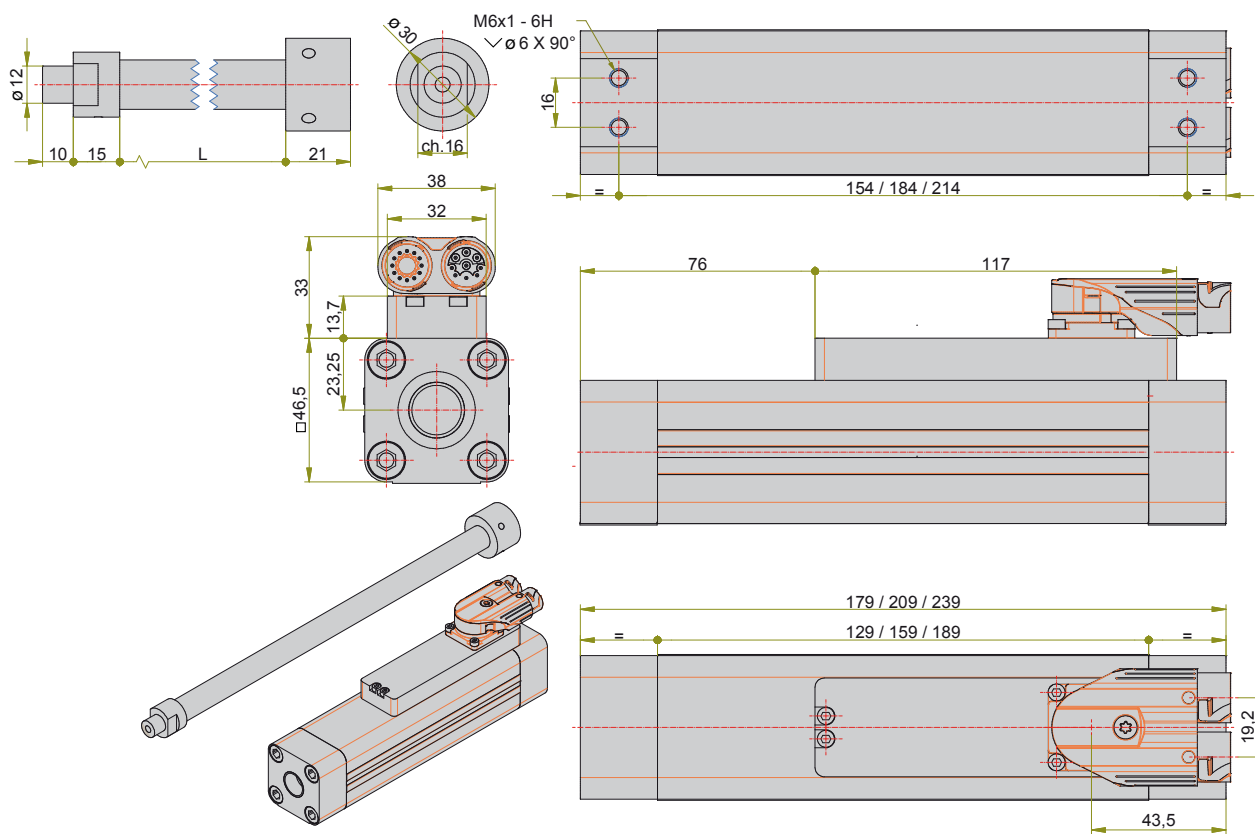

ETT050

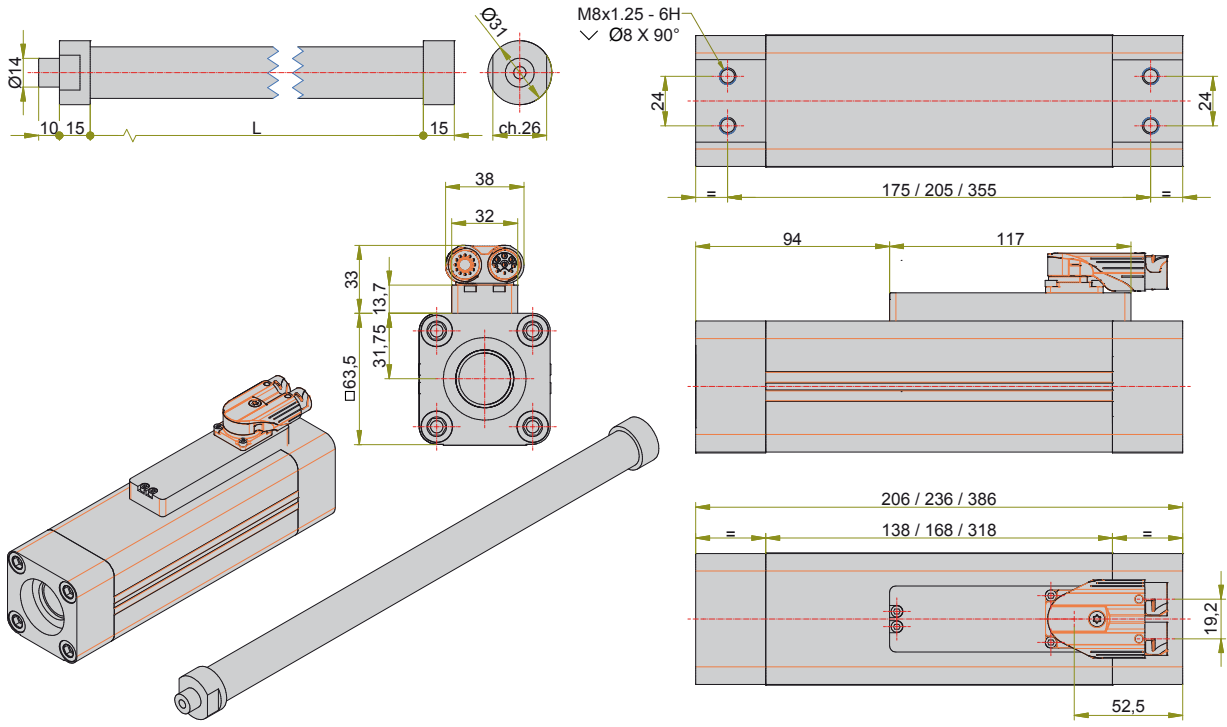

Layout and Connectors ETT032 & ETT050

Power connector

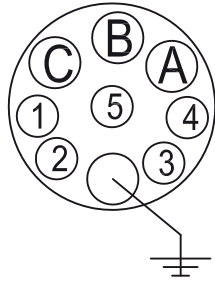

Feedback connector

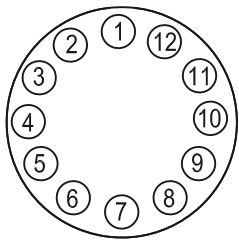

Pin	Description
A	U
B	W
C	V
PE	PE
1	nc
2	nc
3	nc
4	nc
5	nc

Pin	Description
1	cos -
2	cos +
3	nc
4	KTY84 -
5	KTY84 +
6	nc
7	sin -
8	sin +
9	nc
10	+5 V
11	nc
12	GND

ETT025 available with flying leads only

Accessories and Options

Mounting Methods

Front and Rear Plate

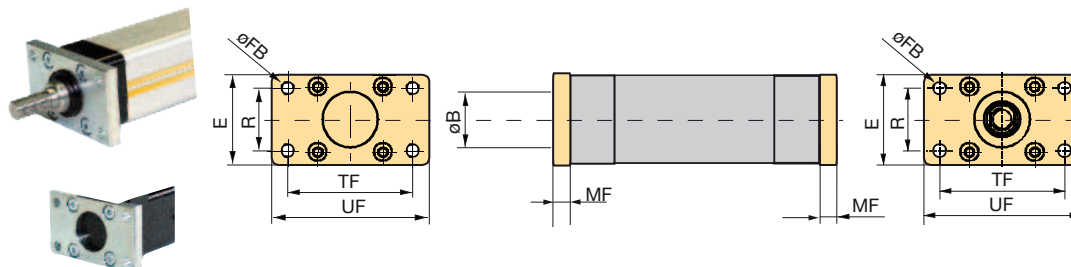

Front and rear plate dimensions

	Order no. (1 piece)	UF	E	TF	øFB	R	MF	øB
		[mm]	[mm]	[mm]	[mm]	[mm]	[mm]	[mm]
ETT032	0112.918	80	48	64	7	32	10	30
ETT050	0122.918	110	65	90	9	45	12	40

Spare parts delivery is including screws for mounting.

Please note that front and rear plate as spare parts must be ordered separately.

Mounting Brackets

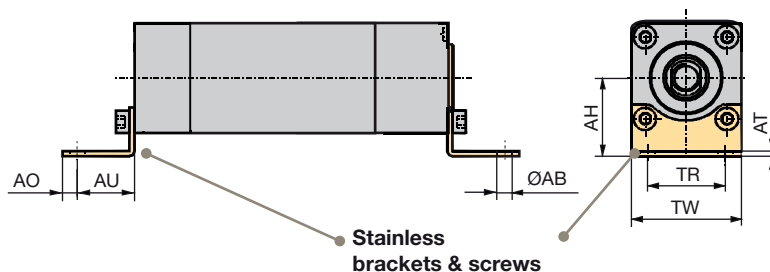
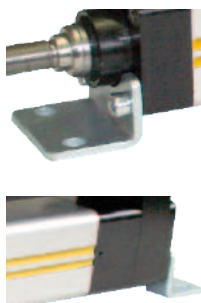

	Order no. Front & Terminal bracket	AH	AT	TR	øAB (H14)	AO	AU	TW
		[mm]	[mm]	[mm]	[mm]	[mm]	[mm]	[mm]
ETT032	0112.916	32	4	32	7	8	24	46.5
ETT050	0122.916	44	4	45	9	12	32	63.5

Spare parts delivery is including screws for mounting.

* For protection classes, we recommend GEOMET® coated screws (thin layer corrosion protection).

Mounting Flanges

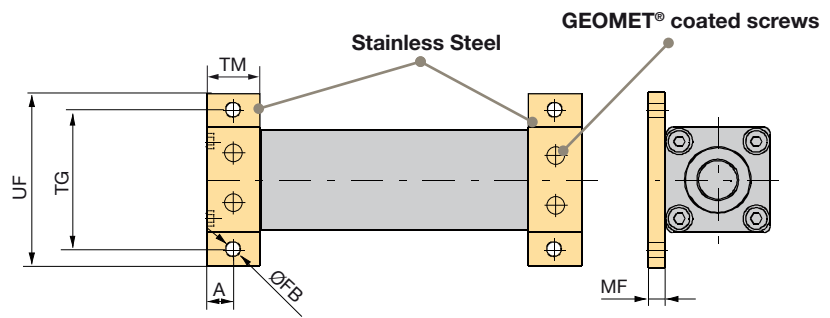
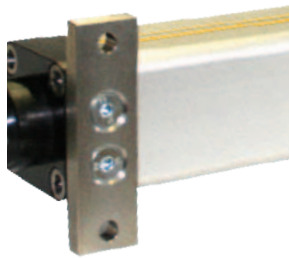

	Order no. (1 piece)	TG	UF	ØFB	TM	MF	A
		[mm]	[mm]	[mm]	[mm]	[mm]	[mm]
ETT032	0112.917	62	78	6.6	25	8	12.5
ETT050	0122.917	84	104	9	30	10	15

Spare parts delivery is including screws for mounting.

* For protection classes, we recommend GEOMET® coated screws (thin layer corrosion protection).

Cylinder Rod Version

Plastic Swivel Rod Eye

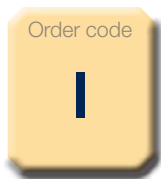

manufactured by igus®

KBRM	-05	-06	-08
	ETT025	ETT032	ETT050
d1 E10	5	6	8
d2	18	20	24
d3	M5	M6	M8
d4	9.0	10.0	13.0
d5	12.0	13.0	16.0
C1	6.0	7.0	9.0
B without MH*	8	9	12
B with MH*	8.1	9.2	12.2
h1	27	30	36
l1	10	12	16
l2	36	40	48
W	SW09	SW11	SW14
Pitch	30°	29°	25°

* MH: metal insert

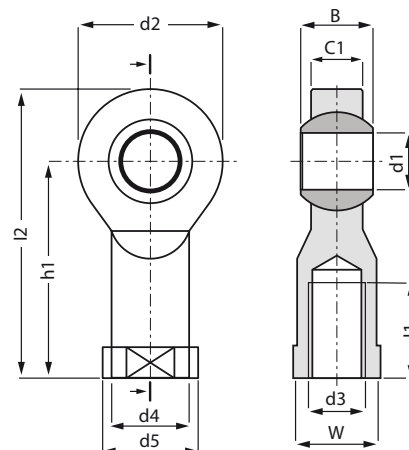

Plastic Rod Clevis

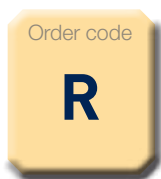

manufactured by igus®

GERM	-05	-06	-08
	ETT025	ETT032	ETT050
d1 H9	5	6	8
g h11	12	12	16
a1 +0.3 / -0.16	12	12	16
a2 +0.3 / -0.16	12	12	16
b1 B13	6	6	8
d2 6H*	M5	M6	M8
d3 +0.3 / -0.3	10.0	10.0	14.0
l2 +0.5 / -0.5	31.0	31.0	42.0
h1 +0.3 / -0.3	24.0	24.0	32.0
l1 +0.2 / -0.2	9.0	9.0	12.0

* Thread tolerance

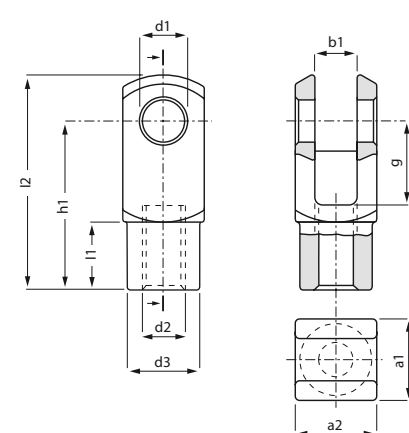

Alignment Coupler

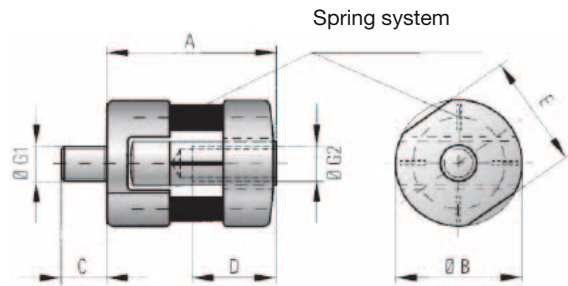
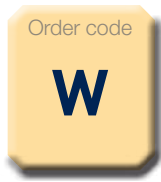

manufactured by R+W®

LK	-70	-150	-300
	ETT025	ETT032	ETT050
Pressure force [N]	70	150	300
A	24	33	41.5
B	18	22	30
G1/2	M5	M6	M8
G1/2* [Nm]	4	7	18
C	6.5	8	10
D	10	12	16
E	16	20	27
Mass	11	23	57
Lateral restoring force _(max) (N)	10	18	48
lateral _(max) [mm]	0.5	0.5	0.5
angular _(max)	1.5°	1.5°	1.5°

* Max. tightening torque thread

Feedback

Internal position sensor

The standard position sensor is an analogue Sine/Cosine 1 Vpp signal. The table shows the different position feedback:

Sine /Cosine	Standard feedback
---------------------	-------------------

External position sensor

For highest precision demands an external position sensor is available:

TTK50 – HXQ0K02	Hiperface external feedback, cable length 2 m <ul style="list-style-type: none"> • Measure step: 0.244 µm at interpolation of the sine/cosine signals with e.g. 12 bit • Length of period: 1 mm • Measured length: 940 mm max. • System accuracy (ambient temperature): ±10 µm (+20 °C) • Repeat accuracy: <5 µm • Hysteresis error: <10 µm
MSK500010KE1/20LDI000505	Incremental linear feedback <ul style="list-style-type: none"> • Resolution up to 0.001 mm • Free programmable parameters (e.g. resolution) via optical interface • Status LEDs • Real-time data processing • Scale MB500 (linear) / MR500 (radial) • Fix and periodical reference signals

Order Code

ETT Electric Tubular Motor (Complete Unit)

	1	2	3	4	5	6	7	8	9
Order example	ETT	032	S1	CS	M	N	...	C	

1 Type	ETT	Electric Tubular Motor
2 Size	025	ISO 6432 - Bore 25 mm
	032	ISO 6432 - Bore 32 mm
	050	ISO 6432 - Bore 50 mm
3 Winding	S1	Serial, Stack Length 1
	S2	Serial, Stack Length 2
	S3	Serial, Stack Length 3
4 Connection and Feedback Type	CS	Intercontec Connector (Springtec EEDA101NN0000002000) - Feedback Analogue SinCos 1 Vpp - Not for ETT025
	1S	Flying leads, Length 1 m, rear output - Feedback Analogue SinCos 1 Vpp - Only ETT025
	2S	Flying leads, Length 2.5 m, rear output - Feedback Analogue SinCos 1 Vpp - Only ETT025
	5S	Flying leads, Length 5 m, rear output - Feedback Analogue SinCos 1 Vpp - Only ETT025
5 Rod End Mounting - Front / Rear	M	Male Thread / Cap End (M5 for ETT025, M6 for ETT032, M8 for ETT050)
	F	Female Thread / Cap End (M5 for ETT025, M6 for ETT032, M8 for ETT050)
	N	Male Thread / Male Thread (M5 for ETT025, M6 for ETT032, M8 for ETT050)
	G	Female Thread / Female Thread (M5 for ETT025, M6 for ETT032, M8 for ETT050)
	W	Linear Coupling / Cap End R+W: LK70 for ETT025, LK150 for ETT032, LK300 for ETT050
	I	Swivel Rod Eye igus KBRM-05 for ETT025
	R	Clevis igus GERM05 for ETT025
	X	Special (Customized version - Please contact Parker)
6 Fixed Field	N	Fixed field
7 Stroke*	30	30 mm

	720	720 mm
8 Protection Class	C	IP67
9 Customized Options	Blank for standard motors	

* Please see values in table "ETT - Length of Rod / Table of Stroke" (page 18)

ETT - Motor and Signal Cable

	1	2	3	4	5	6	7
Order example	ETT-CAP	X	003	PM	-	Y1	SL - 00

1 Cable Type	ETT-CAP	Power cable for ETT
	ETT-CAS	Signal cable for ETT - COS
2 Fixed Field	X	Fixed field
3 Cable Length	001	1 m
	003	3 m
	005	5 m
	007	7 m
	010	10 m
	015	15 m
	020	20 m
4 Application Type	PM	High flex cable
5 Connector	Y1	Intercontec Connector
	X	Special Execution
6 Drive Type	SL	SLVD-N Drive
	C3	Compax3
7 Option	00	No special option Special customer drawing

ETT Electric Tubular Motor (Rod only)

	1	2	3	4	5
Order example	ETT-R	032	M	...	

1	Type	ETT-R Electric Tubular Motor - Rod only
2	Size	025 ISO 6432 - Bore 25 mm 032 ISO 6432 - Bore 32 mm 050 ISO 6432 - Bore 50 mm
3	Rod End Mounting - Front / Rear	M Male Thread / Cap End (M5 for ETT025, M6 for ETT032, M8 for ETT050) F Female Thread / Cap End (M5 for ETT025, M6 for ETT032, M8 for ETT050) N Male Thread / Male Thread (M5 for ETT025, M6 for ETT032, M8 for ETT050) G Female Thread / Female Thread (M5 for ETT025, M6 for ETT032, M8 for ETT050) W Linear Coupling / Cap End R+W: LK70 for ETT025, LK150 for ETT032, LK300 for ETT050 I Swivel Rod Eye igus KBRM-05 for ETT025 R Clevis igus GERM05 for ETT025 X Special (Customized version - Please contact Parker)
4	Length*	215 215 mm 944 944 mm
5	Customized Options	Blank for standard motors

* Please see values in table "ETT - Length of Rod / Table of Stroke" (page 18)

ETT Electric Tubular Motor (Coil only)

	1	2	3	4	5	6	7
Order example	ETT-C	032	S1	CS	N	C	

1	Type	ETT-C Electric Tubular Motor - Coil only
2	Size	025 ISO 6432 - Bore 25 mm 032 ISO 6432 - Bore 32 mm 050 ISO 6432 - Bore 50 mm
3	Winding	S1 Serial, Stack Length 1 S2 Serial, Stack Length 2 S3 Serial, Stack Length 3
4	Connection and Feedback Type	CS Intercontec Connector (Springtec EEDA101NN00000002000) - Feedback Analogue SinCos 1 Vpp - Not for ETT025 1S Flying leads, Length 1 m, rear output - Feedback Analogue SinCos 1 Vpp - Only ETT025 2S Flying leads, Length 2.5 m, rear output - Feedback Analogue SinCos 1 Vpp - Only ETT025 5S Flying leads, Length 5 m, rear output - Feedback Analogue SinCos 1 Vpp - Only ETT025
5	Fixed Field	N Fixed Field
6	Protection Class	C IP67
7	Customized Options	Blank for standard motors

ETT - Length of Rod / Table of Stroke

ETT025

Length of Rod [mm]	Stroke		
	Stack Length		
	S1 [mm]	S2 [mm]	S3 [mm]
215	30		
245	60		
275	90		
305	120		
335	150		
365	180		
395	210		
425	240		
455	270		
485	300		
515*	330		
545*	360		

ETT050

Length of Rod [mm]	Stroke		
	Stack Length		
	S1 [mm]	S2 [mm]	S3 [mm]
254	30	0	0
284	60	30	0
314	90	60	0
344	120	90	0
374	150	120	0
404	180	150	0
434	210	180	30
464	240	210	60
494	270	240	90
524	300	270	120
554	330	300	150
584	360	330	180
614	390	360	210
644	420	390	240
674	450	420	270
704	480	450	300
734	510	480	330
764	540	510	360
794	570	540	390
824	600	570	420
854	630	600	450
884*	660	630	480
914*	690	660	510
944*	720	690	540

ETT032

Length of Rod [mm]	Stroke		
	Stack Length		
	S1 [mm]	S2 [mm]	S3 [mm]
221	30	0	0
251	60	30	0
281	90	60	30
311	120	90	60
341	150	120	90
371	180	150	120
401	210	180	150
431	240	210	180
461	270	240	210
491	300	270	240
521	330	300	270
551	360	330	300
581	390	360	330
611	420	390	360
641	450	420	390
671	480	450	420
701	510	480	450
731*	540	510	480
761*	570	540	510
791*	600	570	540
821*	630	600	570
851*	660	630	600

* Needs specific mechanical mounting. Special length available on request



Parker's Motion & Control Technologies

At Parker, we're guided by a relentless drive to help our customers become more productive and achieve higher levels of profitability by engineering the best systems for their requirements. It means looking at customer applications from many angles to find new ways to create value. Whatever the motion and control technology need, Parker has the experience, breadth of product and global reach to consistently deliver. No company knows more about motion and control technology than Parker. For further info call 00800 27 27 5374



Aerospace

Key Markets

Aftermarket services
Commercial transports
Engines
General & business aviation
Helicopters
Launch vehicles
Military aircraft
Missiles
Power generation
Regional transports
Unmanned aerial vehicles

Key Products

Control systems & actuation products
Engine systems & components
Fluid conveyance systems & components
Fluid metering, delivery & atomization devices
Fuel systems & components
Fuel tank inerting systems
Hydraulic systems & components
Thermal management
Wheels & brakes



Climate Control

Key Markets

Agriculture
Air conditioning
Construction Machinery
Food & beverage
Industrial machinery
Life sciences
Oil & gas
Precision cooling
Process
Refrigeration
Transportation

Key Products

Accumulators
Advanced actuators
CO₂ controls
Electronic controllers
Filter driers
Hand shut-off valves
Heat exchangers
Hose & fittings
Pressure regulating valves
Refrigerant distributors
Safety relief valves
Smart pumps
Solenoid valves
Thermostatic expansion valves



Electromechanical

Key Markets

Aerospace
Factory automation
Life science & medical
Machine tools
Packaging machinery
Paper machinery
Plastics machinery & converting
Primary metals
Semiconductor & electronics
Textile
Wire & cable

Key Products

AC/DC drives & systems
Electric actuators, gantry robots & slides
Electrohydraulic actuation systems
Electromechanical actuation systems
Human machine interface
Linear motors
Stepper motors, servo motors, drives & controls
Structural extrusions



Filtration

Key Markets

Aerospace
Food & beverage
Industrial plant & equipment
Life sciences
Marine
Mobile equipment
Oil & gas
Power generation & renewable energy
Process
Transportation
Water Purification

Key Products

Analytical gas generators
Compressed air filters & dryers
Engine air, coolant, fuel & oil filtration systems
Fluid condition monitoring systems
Hydraulic & lubrication filters
Hydrogen, nitrogen & zero air generators
Instrumentation filters
Membrane & fiber filters
Microfiltration
Sterile air filtration
Water desalination & purification filters & systems



Fluid & Gas Handling

Key Markets

Aerial lift
Agriculture
Bulk chemical handling
Construction machinery
Food & beverage
Fuel & gas delivery
Industrial machinery
Life sciences
Marine
Mining
Mobile
Oil & gas
Renewable energy
Transportation

Key Products

Check valves
Connectors for low pressure fluid conveyance
Deep sea umbilicals
Diagnostic equipment
Hose couplings
Industrial hose
Mooring systems & power cables
PTFE hose & tubing
Quick couplings
Rubber & thermoplastic hose
Tube fittings & adapters
Tubing & plastic fittings



Hydraulics

Key Markets

Aerial lift
Agriculture
Alternative energy
Construction machinery
Forestry
Industrial machinery
Machine tools
Marine
Material handling
Mining
Oil & gas
Power generation
Refuse vehicles
Renewable energy
Truck hydraulics
Turf equipment

Key Products

Accumulators
Cartridge valves
Electrohydraulic actuators
Human machine interfaces
Hybrid drives
Hydraulic cylinders
Hydraulic motors & pumps
Hydraulic systems
Hydraulic valves & controls
Hydrostatic steering
Integrated hydraulic circuits
Power take-offs
Power units
Rotary actuators
Sensors



Pneumatics

Key Markets

Aerospace
Conveyor & material handling
Factory automation
Life science & medical
Machine tools
Packaging machinery
Transportation & automotive

Key Products

Air preparation
Brass fittings & valves
Manifolds
Pneumatic accessories
Pneumatic actuators & grippers
Pneumatic valves & controls
Quick disconnects
Rotary actuators
Rubber & thermoplastic hose & couplings
Structural extrusions
Thermoplastic tubing & fittings
Vacuum generators, cups & sensors



Process Control

Key Markets

Alternative fuels
Biopharmaceuticals
Chemical & refining
Food & beverage
Marine & shipbuilding
Medical & dental
Microelectronics
Nuclear Power
Offshore oil exploration
Oil & gas
Pharmaceuticals
Power generation
Pulp & paper
Steel
Water/wastewater

Key Products

Analytical Instruments
Analytical sample conditioning products & systems
Chemical injection fittings & valves
Fluoropolymer chemical delivery fittings, valves & pumps
High purity gas delivery fittings, valves, regulators & digital flow controllers
Industrial mass flow meters/controllers
Permanent no-weld tube fittings
Precision industrial regulators & flow controllers
Process control double block & bleeds
Process control fittings, valves, regulators & manifold valves



Sealing & Shielding

Key Markets

Aerospace
Chemical processing
Consumer
Fluid power
General industrial
Information technology
Life sciences
Microelectronics
Military
Oil & gas
Power generation
Renewable energy
Telecommunications
Transportation

Key Products

Dynamic seals
Elastomeric o-rings
Electro-medical instrument design & assembly
EMI shielding
Extruded & precision-cut, fabricated elastomeric seals
High temperature metal seals
Homogeneous & inserted elastomeric shapes
Medical device fabrication & assembly
Metal & plastic retained composite seals
Shielded optical windows
Silicone tubing & extrusions
Thermal management
Vibration dampening

Parker Worldwide

Europe, Middle East, Africa

AE – United Arab Emirates, Dubai
Tel: +971 4 8127100
parker.me@parker.com

AT – Austria, Wiener Neustadt
Tel: +43 (0)2622 23501-0
parker.austria@parker.com

AT – Eastern Europe, Wiener Neustadt
Tel: +43 (0)2622 23501 900
parker.easteurope@parker.com

AZ – Azerbaijan, Baku
Tel: +994 50 2233 458
parker.azerbaijan@parker.com

BE/LU – Belgium, Nivelles
Tel: +32 (0)67 280 900
parker.belgium@parker.com

BG – Bulgaria, Sofia
Tel: +359 2 980 1344
parker.bulgaria@parker.com

BY – Belarus, Minsk
Tel: +375 17 209 9399
parker.belarus@parker.com

CH – Switzerland, Etoy
Tel: +41 (0)21 821 87 00
parker.switzerland@parker.com

CZ – Czech Republic, Klecany
Tel: +420 284 083 111
parker.czechrepublic@parker.com

DE – Germany, Kaarst
Tel: +49 (0)2131 4016 0
parker.germany@parker.com

DK – Denmark, Ballerup
Tel: +45 43 56 04 00
parker.denmark@parker.com

ES – Spain, Madrid
Tel: +34 902 330 001
parker.spain@parker.com

FI – Finland, Vantaa
Tel: +358 (0)20 753 2500
parker.finland@parker.com

FR – France, Contamine s/Arve
Tel: +33 (0)4 50 25 80 25
parker.france@parker.com

GR – Greece, Athens
Tel: +30 210 933 6450
parker.greece@parker.com

HU – Hungary, Budaörs
Tel: +36 23 885 470
parker.hungary@parker.com

IE – Ireland, Dublin
Tel: +353 (0)1 466 6370
parker.ireland@parker.com

IT – Italy, Corsico (MI)
Tel: +39 02 45 19 21
parker.italy@parker.com

KZ – Kazakhstan, Almaty
Tel: +7 7273 561 000
parker.easteurope@parker.com

NL – The Netherlands, Oldenzaal
Tel: +31 (0)541 585 000
parker.nl@parker.com

NO – Norway, Asker
Tel: +47 66 75 34 00
parker.norway@parker.com

PL – Poland, Warsaw
Tel: +48 (0)22 573 24 00
parker.poland@parker.com

PT – Portugal, Leca da Palmeira
Tel: +351 22 999 7360
parker.portugal@parker.com

RO – Romania, Bucharest
Tel: +40 21 252 1382
parker.romania@parker.com

RU – Russia, Moscow
Tel: +7 495 645-2156
parker.russia@parker.com

SE – Sweden, Spånga
Tel: +46 (0)8 59 79 50 00
parker.sweden@parker.com

SK – Slovakia, Banská Bystrica
Tel: +421 484 162 252
parker.slovakia@parker.com

SL – Slovenia, Novo Mesto
Tel: +386 7 337 6650
parker.slovenia@parker.com

TR – Turkey, Istanbul
Tel: +90 216 4997081
parker.turkey@parker.com

UA – Ukraine, Kiev
Tel: +380 44 494 2731
parker.ukraine@parker.com

UK – United Kingdom, Warwick
Tel: +44 (0)1926 317 878
parker.uk@parker.com

ZA – South Africa, Kempton Park
Tel: +27 (0)11 961 0700
parker.southafrica@parker.com

North America

CA – Canada, Milton, Ontario
Tel: +1 905 693 3000

US – USA, Cleveland
Tel: +1 216 896 3000

Asia Pacific

AU – Australia, Castle Hill
Tel: +61 (0)2-9634 7777

CN – China, Shanghai
Tel: +86 21 2899 5000

HK – Hong Kong
Tel: +852 2428 8008

IN – India, Mumbai
Tel: +91 22 6513 7081-85

JP – Japan, Tokyo
Tel: +81 (0)3 6408 3901

KR – South Korea, Seoul
Tel: +82 2 559 0400

MY – Malaysia, Shah Alam
Tel: +60 3 7849 0800

NZ – New Zealand, Mt Wellington
Tel: +64 9 574 1744

SG – Singapore
Tel: +65 6887 6300

TH – Thailand, Bangkok
Tel: +662 186 7000-99

TW – Taiwan, Taipei
Tel: +886 2 2298 8987

South America

AR – Argentina, Buenos Aires
Tel: +54 3327 44 4129

BR – Brazil, Sao Jose dos Campos
Tel: +55 800 727 5374

CL – Chile, Santiago
Tel: +56 2 623 1216

MX – Mexico, Toluca
Tel: +52 72 2275 4200

192-571001N1

July 2013

We reserve the right to make technical changes. The data correspond to the technical state at the time of printing.
© 2013 Parker Hannifin Corporation.
All rights reserved.



EMEA Product Information Centre

Free phone: 00 800 27 27 5374

(from AT, BE, CH, CZ, DE, DK, EE, ES, FI, FR, IE, IL, IS, IT, LU, MT, NL, NO, PL, PT, RU, SE, SK, UK, ZA)

US Product Information Centre

Toll-free number: 1-800-27 27 537

www.parker.com

Autoryzowany dystrybutor Parker:

ARA
PNEUMATIK

53-012 Wrocław tel. 71 364 72 82
ul. Wyścigowa 38 fax 71 364 72 83

www.arapneumatik.pl

