

ISO 9001:2008 by L.R.
PED DIR. 97/23/EC by L.R.
ATEX DIR. 94/9/EC by B.V.
FIRE SAFE EXECUTION by L.R.
ISO 15848 by TÜV
ANTISTATIC DEVICE by L.R.
FIRE SAFE TESTED ISO 10497 by L.R.

TYPE
FC2
PN 63 ÷ 100 ÷ 160
ANSI 600

NORME E DIRETTIVE APPLICATE DISPONIBILI AL SEGUENTE LINK:
STANDARD AND DIRECTIVE APPLIED AVAILABLE AT FOLLOWING LINK:
http://www.adlerspa.com/pdf/NORME_ADLER.pdf

VALVOLE A SFERA "CORPO PIATTO" SPLIT BODY PASSAGGIO TOTALE

ISO nbr° LRC 0160281 QMS issued by L.R.Q.A. PED nbr° COV 0212112/01 issued by L.R.V.
ATEX nbr° 40.2003.4392 issued by B.V. ISO 15848 nbr° I-148466/1-/2 issued by TÜV

FULL BORE ACCORDING
TO ISO 14313

On request
S.I.L. 3
According to IEC 61508

On request
FIRE SAFE
According to ISO 10497
"ISO-FT"

CONSTRUCTION ACCORDING TO:
BS EN 12516-2 - ANSI B16.34
ISO 14313 - EN 558

BALL VALVES
"WAFER TYPE" FULL BORE SPLIT BODY
FLANSCHKUGELHÄHNE IN "KOMPAKTBAUWEISE"
VOLLER DURCHGANG ZWEITEILIGES GEHÄUSE

PRZEDSTAWICIEL W POLSCE:

ARA
PNEUMATIK

53-012 Wrocław tel. 71 364 72 85
ul. Wysięgowa 38 fax 71 364 72 83

www.arapneumatik.pl



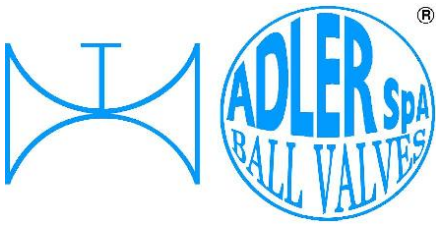

ISO 9001:2008 by L.R.
 PED DIR. 97/23/EC by L.R.
 ATEX DIR. 94/9/EC by B.V.
 FIRE SAFE EXECUTION by L.R.
 ISO 15848 by TÜV
 ANTISTATIC DEVICE by L.R.
 FIRE SAFE TESTED ISO 10497 by L.R.

TYPE
FC2
 PN 63 ÷ 100 ÷ 160
 ANSI 600

VALVOLA A SFERA "CORPO PIATTO" SPLIT BODY PASSAGGIO TOTALE
BALL VALVES "WAFFER TYPE" SPLIT BODY FULL BORE
ROBINETS A BOISSEAU SPHERIQUE "WAFFER" PASSAGE INTEGRAL 2 PIECES
FLANSCHKUGELHÄHNE IN "KOMPAKTBAUWEISE" VOLLER DURCHGANG ZWEITEILIGES GEHÄUSE

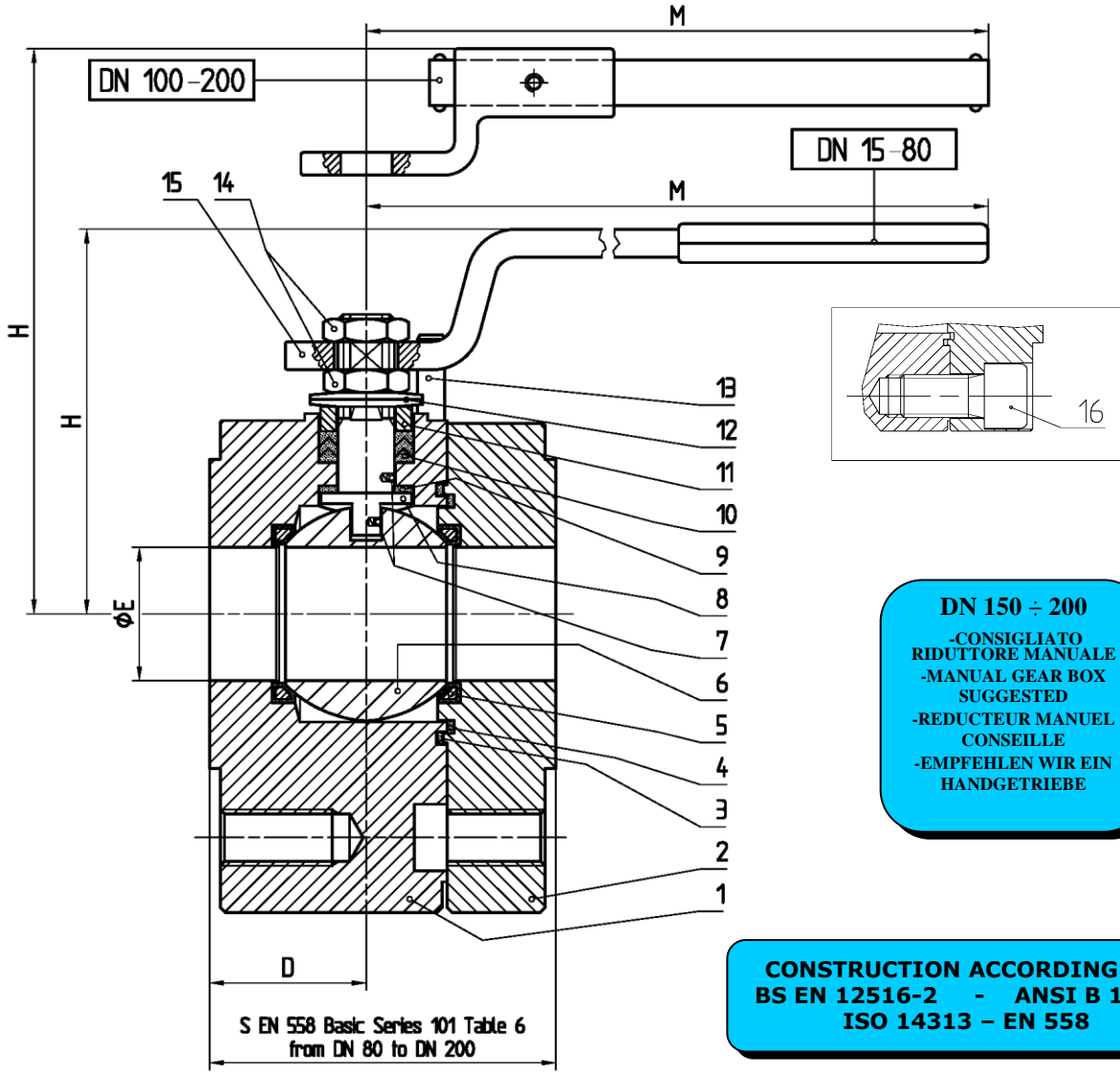

DN 150 ÷ 200
 -CONSIGLIATO
 RIDUTTORE MANUALE
 -MANUAL GEAR BOX
 SUGGESTED
 -REDUCTEUR MANUEL
 CONSEILLE
 -EMPFEHLEN WIR EIN
 HANDGETRIEBE

CONSTRUCTION ACCORDING TO:
 BS EN 12516-2 - ANSI B 16.34
 ISO 14313 - EN 558

FC2/15 RIPRODUZIONE VIETATA - COPYRIGHT

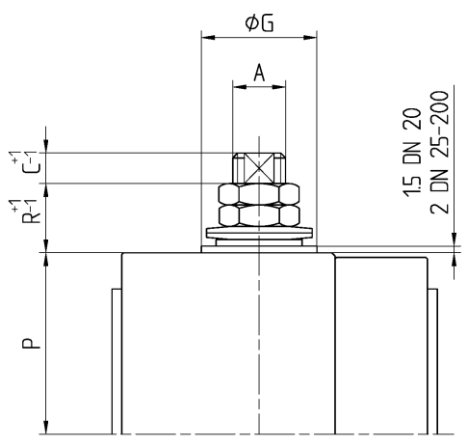

• ACCOPIAMENTO VALVOLA
 ATTUATORE
 • CONNECTION VALVE
 ACTUATOR
 • ACCOUPLEMENT ROBINET-
 ACTIONNEUR
 • ZUSAMMENBAU KUGELHAHN
 ANTRIEB

ISO-5211

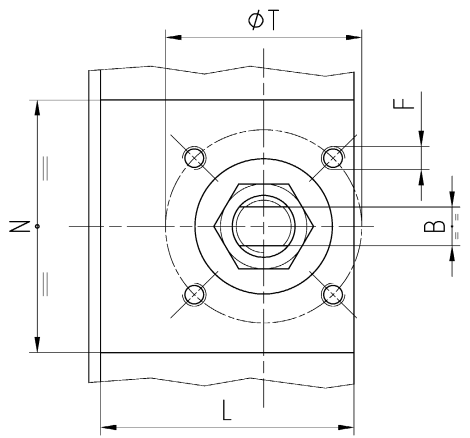

N.	DESCRIZIONE DESCRIPTION BESCHREIBUNG	MATERIALI MATERIALS MATERIAUX WERKSTOFFE
1	CORPO BODY CORPS KÖRPER	ASTM A105 ASTM A479 304/304L ASTM A479 316/316L
2	LATERALE END LATERAL GEGENGEHÄUSE	ASTM A105 ASTM A479 304/304L ASTM A479 316/316L
3*	O-RING	FKM - (VITON)
4*	ANELLO SEAL ANNEAU DICHTUNGSRING	P.T.F.E.
5*	SEDE RINFORZATA SEAT REINFORCED SIEGE RENFORCEE SITZRING VERSTÄRKT	P.T.F.E. / STAINLESS STEEL
6	SFERA BALL BOULE KUGEL	ASTM A479 304/304L ASTM A351 CF8 ASTM A479 316/316L ASTM A351 CF8M
7	DISPOSITIVO ANTISTATICO ANTISTATIC DEVICE CONTACT ANTISTATIQUE ANTISTATIK VORRICHTUNG	ASTM A479 316/316L
8	STELO STEM TIGE SPINDEL	ASTM A479 304/304L ASTM A479 316/316L

N.	DESCRIZIONE DESCRIPTION BESCHREIBUNG	MATERIALI MATERIALS MATERIAUX WERKSTOFFE
9*	BUSSOLA STEM SEAL JOINT TIGE UNTERE SPINDELABDICHTUNG	P.T.F.E.
10 *	PACCO A "V" CHEVRON RINGS JOINT A "V" 3 FACHE DACHMANSCHETTE	P.T.F.E. / GRAFITE P.T.F.E. / GRAPHITE P.T.F.E. / GRAPHITE P.T.F.E. / GRAPHIT
11	PREMIBUSSOLA PRESSING BUSH PRESSE RONDELLE STOPFBUCHSDRUCKRING	ASTM A479 304
12	MOLLE A TAZZA SPRING WASHERS RONDELLES BELLEVILLE TELLERFEDERN	C72/50Cr V ₄ X5CrNi17.7 or X12CrNi17.7 ZINCATO - GALVANIZED - ZINGUE - VERZINKT ON REQUEST
13	VITE DI FERMO E FERMO PIN AND STOP PIN PLOT E PLOT D'ARRET ANSCHLAGBOLZEN	UNI 3740 8.8 UNI 3951 A2-70 ZINCATO - GALVANIZED - ZINGUE - VERZINKT ON REQUEST
14	DADO - CONTRODADO NUT - LOCK NUT ECROU - CONTRE-ECROU MUTTER - KONTERMUTTER	UNI 3740 - 6S ASTM A479 304 ZINCATO - GALVANIZED - ZINGUE - VERZINKT ON REQUEST
15	LEVA WRENCH LEVIER HANDHEBEL	AISI 1010 ASTM A479 304 ZINCATO - GALVANIZED - ZINGUE - VERZINKT ON REQUEST
16	VITE SCREW VIS SCHRAUBE	UNI 3740 8.8 UNI 3951 A2-70 ZINCATO - GALVANIZED - ZINGUE - VERZINKT ON REQUEST

* RICAMBI CONSIGLIATI - RECOMMENDED SPARE PARTS - PIECES DE RECHANGE CONSEILLEES - ERSATZTEIL EMPFEHLUNG

DIMENSIONI - DIMENSION - DIMENSIONS - ABMESSUNGEN

DN	10	15	20	25	32	40	50	65	80	100	125	150	200
A		12	12	16		22	22	30	30	42	42	48	56
B		8	8	10		14	14	18	18	28	28	32	36
C		10	10	10		12	12	17	17	19	19	20	20
D		23,5	24	29,5		37,5	46,5	60	70	91	100	140	165
E		15	19	25		38	51	64	76	101	118	152	203
F		M5	M5	M6		M8	M8	M8	M8	M12	M12	M16	M20
ISO		F03	F03	F05		F07	F07	F07	F07	F12	F12	F14	F16
G		25	25	35		55	55	55	55	85	85	100	130
H		78	80	101		129	139	163	172	225	239	265	307
L		38	39	50,5		65,5	74	88	101	145	155	215,5	276
M		185	185	280		370	370	470	470	750	750	900	1000
N		68	96	97		104	92	82	93	105	128	129	148
P		37	43,5	50		67	76,5	94	97	113	133	160	196,5
R		12	8	16		24	24	21	27	34	28	31	32
PxR		36x14	43,5x8	50x16		67x24	76,5x24	101x14	104x20	118x29	139x22	166,5x24	/
PxR		36x14	43,5x8	46,6x20		67x24	76,5x24	92x23	97x27	120x27	146x15	166,5x24	/
S		68	72	87		107	115	135	150	190	220	280	330
T		36	36	50		70	70	70	70	125	125	140	165
~Kg		2,8	4,5	6,1		11,5	14,5	22	26,5	49	83	140	215

- DATI E CARATTERISTICHE SOGGETTI A VARIAZIONI SENZA PREAVVISO
- SPECIFICATIONS SUBJECT TO MODIFICATION WITHOUT PRIOR NOTICE
- TOUS DROITS DE MODIFICATION RESERVES
- KONSTRUKTIONSÄNDERUNGEN VORBEHALTEN

PN 63

PN 100 - 160

ANSI 600

DN 20 ÷ 40 OPTIONAL



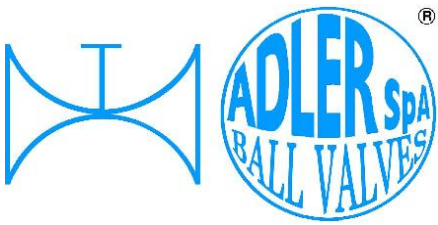

ISO 9001:2008 by L.R.
 PED DIR. 97/23/EC by L.R.
 ATEX DIR. 94/9/EC by B.V.
 FIRE SAFE EXECUTION by L.R.
 ISO 15848 by TÜV
 ANTISTATIC DEVICE by L.R.
 FIRE SAFE TESTED ISO 10497 by L.R.

TYPE
FC2
 PN 63 ÷ 100 ÷ 160
 ANSI 600

VALVOLA A SFERA "CORPO PIATTO" PASSAGGIO TOTALE
 BALL VALVES "WAFER TYPE" FULL BORE

ROBINETS A BOISSEAU SPHERIQUE "WAFER" PASSAGE INTEGRAL
 FLANSCHKUGELHÄHNE IN "KOMPAKTBAUWEISE" VOLLER DURCHGANG

• ESECUZIONI • EXECUTIONS • EXECUTIONS • AUSFÜHRUNGEN



ONLY FOR VALVES \geq DN 50 **S**

FORO DI BILANCIAMENTO
 BALANCING HOLE
 TROU DE BALANCEMENT
 DRUCKENTLASTUNGSBOHRUNG

ON REQUEST AVAILABLE ON DN \leq 40



EXECUTION 4 - 12

EXECUTION 6 - 16

S STANDARD

O OPTIONAL

1 **S**

-MONTAGGIO VITI - SCREW ASSEMBLING
 -MONTAGE VIS - EINBAU MIT SCHRAUBEN



LOCKING DEVICE
 OPEN/CLOSE POSITIONS

4 **S**

-STELO ANTI ESPULSIONE - ANTI BLOW OUT STEM
 -TIGE ANTIEXPULSION - AUSBLASGESICHERTE WELLE

-PACCO A "V" - CHEVRON RINGS
 -JOINT A "V" - 3 FACHE DACHMANSCHETE
 ANTISTATIC DEVICE ANTISTATIK VORRICHTUNG BS 5146

ADLER

UNA GAMMA COMPLETA
 PRIVILEGIANDO LA QUALITA'

A COMPLETE RANGE PRIVILEGING
 THE QUALITY

6 **O**

BREVETTO - PATENTED
 00219688

FKM (VITON)

- "O" RING STELO "O" RING ON STEM
 - TIGE AVEC "O" RING
 - "O" RING IM SPINDELBEREICH

FC2/15 RIPRODUZIONE VIETATA - COPYRIGHT

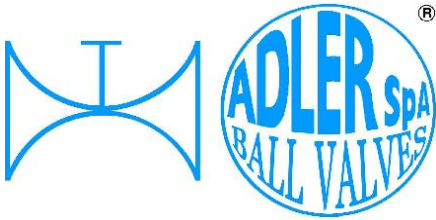

ISO 9001:2008 by L.R.
 PED DIR. 97/23/EC by L.R.
 ATEX DIR. 94/9/EC by B.V.
 FIRE SAFE EXECUTION by L.R.
 ISO 15848 by TÜV
 ANTISTATIC DEVICE by L.R.
 FIRE SAFE TESTED ISO 10497 by L.R.

TYPE
FC2
 PN 63 ÷ 100 ÷ 160
 ANSI 600

VALVOLA A SFERA "CORPO PIATTO" PASSAGGIO TOTALE
 BALL VALVES "WAFER TYPE" FULL BORE

ROBINETS A BOISSEAU SPHERIQUE "WAFER" PASSAGE INTEGRAL
 FLANSCHKUGELHÄHNE IN "KOMPAKTBAUWEISE" VOLLER DURCHGANG

• ESECUZIONI • EXECUTIONS • EXECUTIONS • AUSFÜHRUNGEN

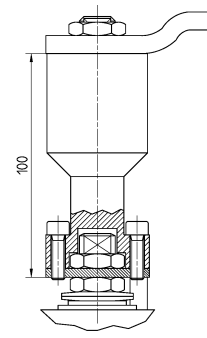
7  **O**

-PROLUNGA STELO -STEM EXTENSION
 -TIGE PROLONGEE -SPINDELVERLÄNGERUNG

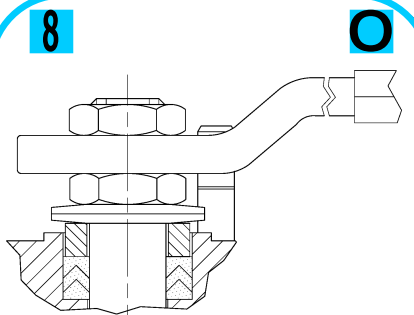
8  **O**

-PARTICOLARI INOX
 -STAINLESS STEEL DETAILS
 -ACCESSOIRES EN INOX
 -EDELSTAHLTEILE

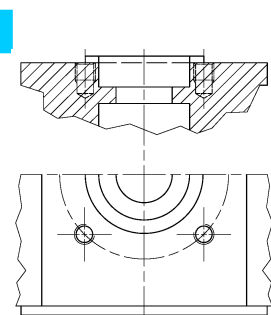
9  **S**

-ATTACCO "ISO" -"ISO" CONNECTIONS
 -SYSTEM "ISO" -ANSCHLUSS "ISO"

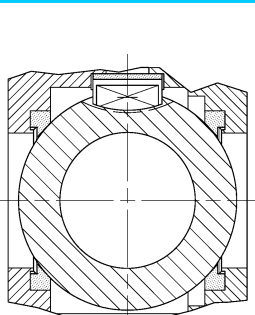
10  **S**

-SFERA CONTENUTA -CONTENTS BALL
 -BOULE CONTENUE
 -NICHT RAUSRAGENDE KUGEL

GEAR BOX
AG series



12 **FIRE SAFE**
ISO 10497 "ISO-FT"
(BS 6755 / API 607) **O**

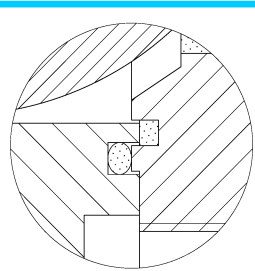

13  **S**

BREVETTO - PATENTED
 00219619

-DOPPIA TENUTA -DOUBLE SEALS
 -DOUBLE ETANCHEITE -DOPPELTE ABDICHTUNG
 -LATERALE A BATTUTA -METAL BEATING END
 -LATERAL AVEC BATTUE MECANIQUE
 -METALLISCHER ANSCHLAG DES GEGENGEHÄUSES

14 **VEDERE / SEE ANSI B16.34** **O**

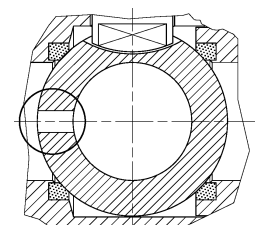

FLUSSO
 FLOW

-FORO DI SCARICO NELLA SFERA
 -OVERPRESSURE HOLE INTO BALL
 -TROU DECOMPRESSION DANS LA BOULE
 -ENTLASTUNGSBOHRUNG IN DER KUGEL
VALVOLA MONO DIREZIONALE
MONO-DIRECTIONAL VALVE

ADLER

UNA GAMMA COMPLETA
 PRIVILEGIANDO LA QUALITA'

A COMPLETE RANGE PRIVILEGING
 THE QUALITY

16  **O**

-FIRE SAFE ISO FT+ "O" RING STELO
 -FIRE SAFE ISO FT+ "O" RING ON STEM
 -SECURITE FEU ISO FT+ TIGE AVEC "O" RING
 -FEUERSICHERE AUSFÜHRUNG ISO FT +
 "O" RING IM SPINDELBEREICH

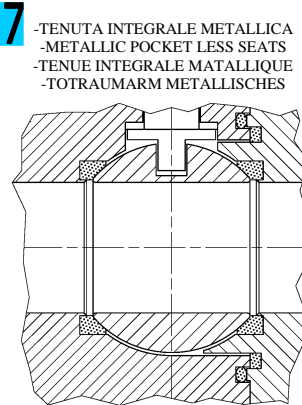
17  **O**

-TENUTA INTEGRALE METALLICA
 -METALLIC POCKET LESS SEATS
 -TENUCE INTEGRALE MATAILLIQUE
 -TOTRAUMARM METALLISCHES

DESIGN CHECK





**VITI D'ASSEMBLAGGIO PER FC2
ASSEMBLING SCREWS FOR FC2
VIS D'ASSEMBLAGE POUR FC2
MONTAGESCHRAUBEN FÜR FC2**

**TABLE
07**

N° VITI – DIMENSIONE • N° SCREW – DIMENSIONS • N° VIS- DIMENSIONS • N° SCHRAUBEN-ABMESSUNGEN

EUROPEAN NORM

DN PN	15	20	25	32	40	50	65	80	100	125	150	200
63	8 M12 X35	8 M16 X40	8 M16 X45	8 M20 X50	8 M20 X50	8 M20 X50	16 M20 X50	16 M20 X55	16 M24 X60	16 M27 X65	16 M30 X70	24 M33 X80
100	8 M12 X35	8 M16 X40	8 M16 X45	8 M20 X50	8 M20 X50	8 M24 X55	16 M24 X60	16 M24 X60	16 M27 X70	16 M30 X75	24 M30 X80	
160	8 M12 X35	8 M16 X40	8 M16 X45	8 M20 X50	8 M20 X55	8 M24 X60	16 M24 X60	16 M24 X65	16 M27 X70	16 M30 X80	24 M30 X85	

ANSI METRIC

(STANDARD ADLER)

Ø Rating	1/2"	3/4"	1"	1 1/4"	1 1/2"	2"	2 1/2"	3"	4"	5"	6"	8"
600	8 M14 X45	8 M16 X45	8 M16 X50	8 M16 X50	8 M20 X55	16 M16 X55	16 M20 X60	16 M20 X65	16 M24 X75	16 M27 X85	24 M27 X90	24 M30 X100

ANSI B1.1 UNC

(ON REQUEST)

Ø Rating	1/2"	3/4"	1"	1 1/4"	1 1/2"	2"	2 1/2"	3"	4"	5"	6"	8"
600	8 1/2 X 1 3/4	8 5/8 X 1 3/4	8 5/8 X 2	8 5/8 X 2	8 3/4 X 2 1/4	16 5/8 X 2 1/4	16 3/4 X 2 1/2	16 3/4 X 2 1/2	16 7/8 X 3	16 1 X 3 1/2	24 1 X 3 1/2	24 1 1/8 X 4

PRZEDSTAWICIEL W POLSCE:

ARA
PNEUMATIK

53-012 Wrocław tel. 71 364 72 85
ul. Wyścigowa 38 fax 71 364 72 83

www.arapneumatik.pl



ADLER SpA – VALVOLE A SFERA
20010 S. STEFANO TICINO (MI) ITALY V.le BORLETTI, 14 Tel. +39/02974842.11 FAX +39/0297271698
E-mail: adler@adlerspa.com <http://www.adlerspa.com>