

TOX®-Kraftpaket typ K, ciśnienie maks. 6 bar

Wersja .30, kompaktowa budowa, zakres sił 10 – 1600 kN

Opatentowany system zaworu przelewowego ze zintegrowanym tłumieniem dostępny na życzenie.

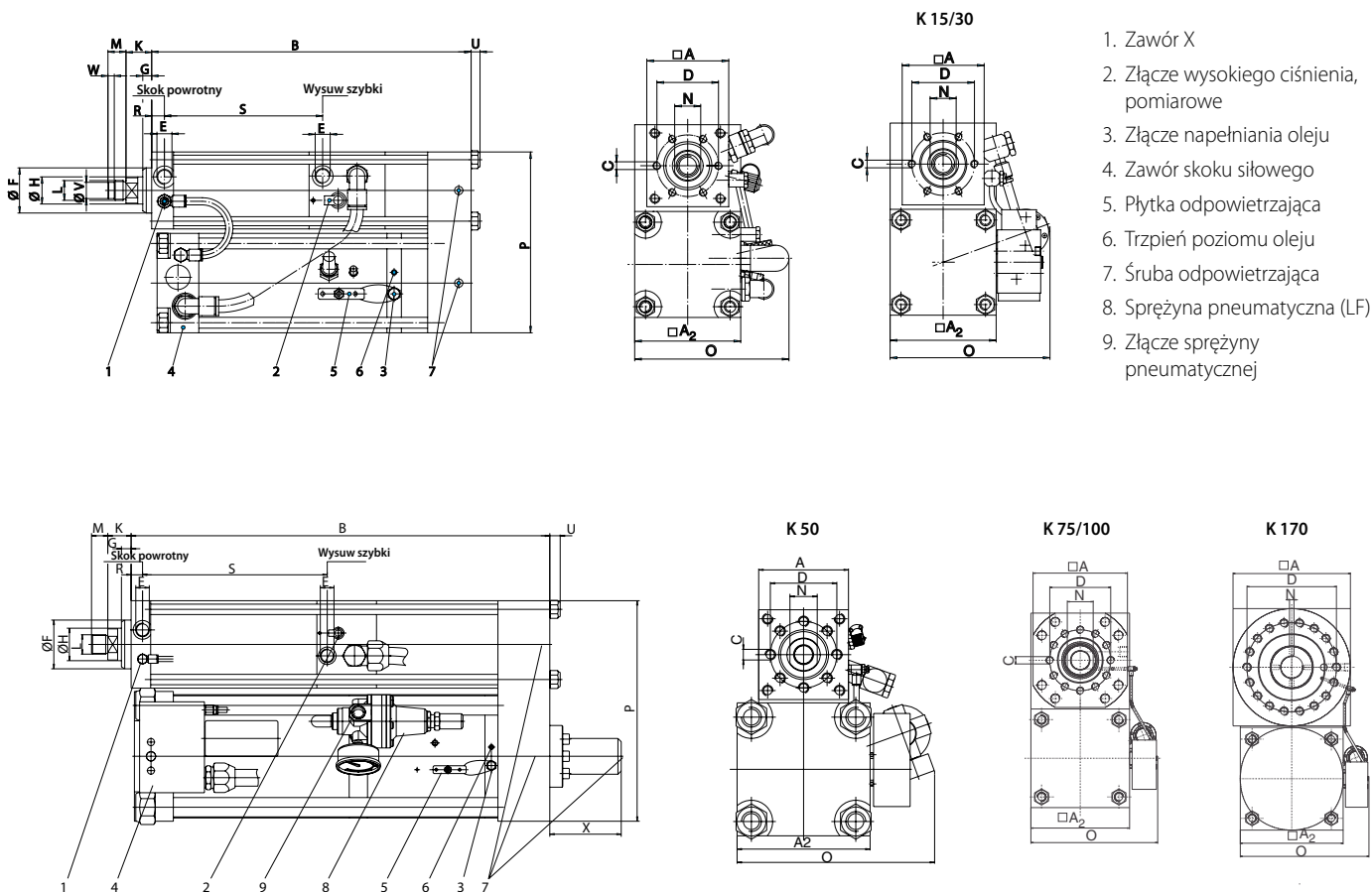

Nr zamówieniowy	skok całkow. siłowy	max. siła przy ciśn. 6 bar kN	siła wysuwu szyb. daN	siła powrotna daN	Preferowana seria: niska cena, krótki czas dostawy																						
					A	A ₁	B	C	D	E	F _r	G	H	K	L	M	N	O	P	R	S	U	Vg6	W	X	*LF**IV	
K 1.30. 100. 6		10,7	69	74	50	70	322	6xM 6x11	40	G1/8	30	10	16	24	M12x1,5	12	14	106	124	11,5	156,5	6	-	-	23	-	x
K 1.30. 200. 10		10,7	69	74	50	70	514	6xM 6x11	40	G1/8	30	10	16	24	M12x1,5	12	14	106	124	11,5	256,5	6	-	-	-	-	x
K 2.30. 100. 5		15,7	141	150	70	85	327	6xM 8x12	54	G1/4	40	10	20	26	M16x1,5	15	17	116	160	13	166	8	-	-	-	-	x
K 2.30. 200. 12		15,7	141	150	70	85	527	6xM 8x12	54	G1/4	40	10	20	26	M16x1,5	15	17	116	160	13	266	8	-	-	-	-	x
K 4.30. 100. 5		38,0	180	197	85	110	353	6xM 8x15	64	G3/8	50	10	30	28,5	M22x2	20	24	165	200	14	175	10	18	7	23	-	x
K 4.30. 200. 10		38,0	180	197	85	110	553	6xM 8x15	64	G3/8	50	10	30	28,5	M22x2	20	24	165	200	14	275	10	18	7	-	-	x
K 8.30. 200. 10		69,0	324	331	110	135	565	6xM10x16	88	G1/2	70	10	45	35	M30x2	25	36	176	250	17	283	12	26	7	30	-	x
K 15.30. 100. 10		130,0	450	520	135	200	585	6xM16x25	100	G1/2	75	15	50	36	M30x2	25	41	320	340	17,5	184,5	16	26	7	110	x	-
K 15.30. 200. 10		130,0	450	520	135	200	645	6xM16x25	100	G1/2	75	15	50	36	M30x2	25	41	320	340	17,5	284,5	16	26	7	110	x	-
K 30.30. 200. 10		321,0	660	890	170	267	740	6xM20x30	132	G3/4	100	18	56	47	M39x2	35	50	470	445	20	336	22	-	-	175	x	-
K 50.30. 100. 10		395,0	710	1110	200	324	715	8xM20x30	150	G3/4	115	25	63	52	M42x2	40	55	540	530	23	243	30	-	-	140	x	-
K 50.30. 200. 10		395,0	710	1110	200	324	785	8xM20x30	150	G3/4	115	25	63	52	M42x2	40	55	540	530	23	343	30	-	-	160	x	-
K 75.30. 200. 10 D		800,0	1270	2040	310	368	972	12xM24x40	200	G1"	150	20	100	60	M64x2	60	85	589,5	681	35	353	30	-	-	123	x	x
K100.30. 200. 10 D		1000,0	1270	2040	310	368	1109	12xM24x40	200	G1"	150	20	100	60	M64x2	60	85	589,5	681	35	353	30	-	-	273	x	x
K170.30. 200. 10 D		1600,0	2000	2560	420	368	1404	18xM30x55	320	G1"	240	35	150	70	M80x2	80	4xØ16	589,5	792	99	843	30	-	-	423	x	x

*LF: Seria ze sprężyną pneumatyczną

D: Opatentowany system zaworu przelewowego. W pozostałych siłownikach dostępny na żądanie.

**IV: Zintegrowany zawór

