

P3L Lite Series Air Preparation System

P3L Lite Lubricator

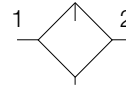

Symbols



- Integral 1/4 ports (BSPP & NPT)
- Robust but lightweight construction
- Proportional oil delivery over a wide range of air flows.
- Screw slot control for precise oil drip rate adjustment

Options:

P 3 L	L A		2	L	P	N	N
Thread type		Port size		Bowl type		Mounting	
BSPP	1	1/4	2	Poly bowl	P	No bracket *	N
NPT	9					* for individual mounting bracket see page:19	
Type				Drain type			
Oil mist standard sight dome				No drain; closed end			
				L			
				N			

Port size	Description	Order Code	Flow dm ³ /s (scfm) *	Max bar (psi)	Height mm (Inches)	Width mm (Inches)	Depth mm (Inches)
1/4"	Poly bowl - No drain	P3LLA12LPNN	23.3 (49)	10 (150)	145 (5.7)	40 (1.57)	40 (1.57)

* flow with 6.3 bar (91.3 psi) inlet pressure and 1 bar (14.5 psi) pressure drop.



www.arapneumatik.pl

ARA Pneumatik Wrocław
53-012 Wrocław ul. Wyścigowa 38
tel. 71 364 72 80; 82 fax 71 364 72 83
pneumatyka@arapneumatik.pl

ARA Pneumatik Oddział Katowice
40-584 Katowice ul. Dworska 13
tel. 32 779 76 40; 41 fax 32 778 20 93
katowice@arapneumatik.pl



PDE2661TCUK
P3L Lite Series Air Preparation System

Specifications

Flow Capacity*	1/4	23.3 dm ³ /s (49 scfm)
Operating Temperature		0°C (32°F) to 50°C (122°F)
Max Supply Pressure		10 bar (150 psi)
Useful Retention		12 cm ³ (0.4 US oz.)
Port Size	BSPP / NPT	1/4
Weight		0.09 kg (20 lbs)

* Inlet pressure 6.3 bar. Pressure drop 1 bar.

Materials of Construction

Body	High Tech Polymer
Bowl	Polycarbonate
Seals	Nitrile
Sight Dome	Polycarbonate
Suggested Lubricant	ISO / ASTM VG32

Flow Charts

Lubricator

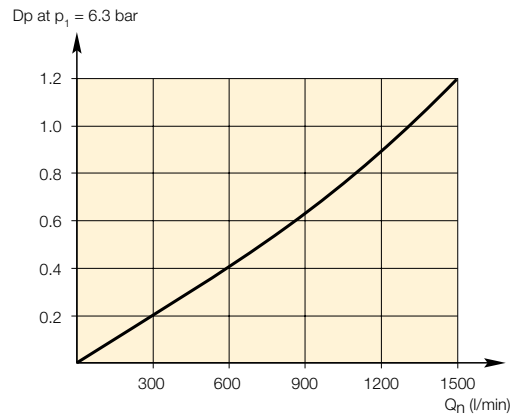

Dimensions

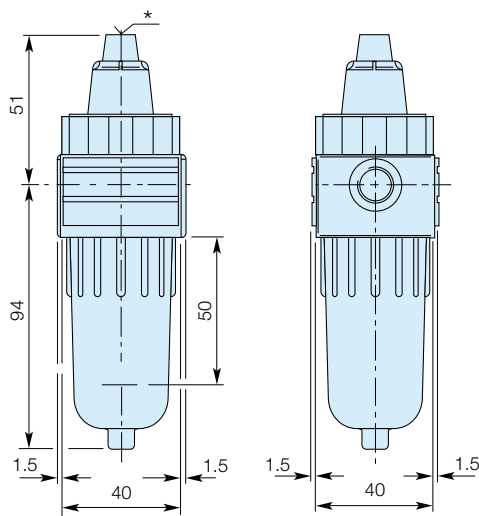

* Oil adjustment screw

Repair and Service Kits

Plastic bowl - no drain	P3LKA00BPN
Lubricator Oil - VG32 - 1 litre	P3YKA00PPBB