

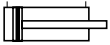



Overview

System	Fig.	Symbol	Series	Page
Double acting without cushioning For contactless position sensing			R6... RK6...	70-76
Double acting with cushioning For contactless position sensing			R5...	70-76
With through piston rod Double acting without cushioning For contactless position sensing			RDU6...	70-76

Piston Rod Cylinders

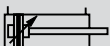
*Round Cylinder
Series R..., RK...
Ø 32-63 mm*



Round Cylinder Ø 32-63 mm

Series R..., RK...
Series RDU...

Versions:

- double acting without cushioning
- double acting with adjustable cushioning
- for contactless position sensing

Universal cylinder for mounting by a thread on the cylinder covers.

Pivot mounted on the front and rear cylinder covers.

The delivery includes:

- 1 Cylinder
- 1 Hexagon nut for piston rod thread and for cylinder mountings

Versions without contactless position sensing on request.

Characteristics

Characteristics	Symbol	Unit	Description			
General Features						
Type			Round cylinder			
Series			R..., RK...			
System			Piston rod cylinder			
	R6..., RK6...		Double acting without cushioning			
	R5...		Double acting with cushioning			
	RDU6...		With through piston rod Double acting without cushioning			
Ambient temperature range	T_{min}	°C	-10	Note: When using below freezing point (°C) please contact as for advice		
	T_{max}	°C	+70			
Medium temperature range	T_{max}	°C	+70			
Weight (mass)		kg	See table			
Medium			Filtered and lubricated or filtered and unlubricated compressed air			
Lubrication			Oil mist lubrication compatible with NBR and PU			
Material						
	Cylinder barrel		Aluminium, anodised			
	Front/rear end caps		Aluminium			
	Piston rod		Steel, high-alloy			
Pneumatic Characteristics						
Nominal pressure	p_n	bar	6			
Piston diameter		mm	32	40	50	63
Operating pressure range	p_{min} p_{max}	bar bar	1 10			
Port size			G1/8	G1/4	G1/4	G3/8
Piston rod diameter		mm	12	16	20	20
Stroke length		mm	For standard stroke lengths see order instructions, max. 500, longer strokes on request			
Cushioned stroke			At both ends progressively adjustable			
Cushioned stroke		mm	22	27	28	28
Piston force and			See page 9			
		air				



Weight (mass) kg

Cylinder version	Cylinder diameter							
	Ø32		Ø40		Ø50		63	
	1*	2*	1*	2*	1*	2*	1*	2*
Basic cylinder Typ R....	0.550	0.150	0.940	0.250	1.400	0.300	1.900	0.400
With through piston rod Typ RDU....	1.100	0.340	1.480	0.560	2.560	0.850	3.260	0.950

* 1 = Weight for cylinder with 100 mm stroke

2 = Weight for every additional 100 mm stroke length

Mounting	Cylinder diameter			
	Ø32	Ø40	Ø50	63
RA (1 bracket)	0.100	0.190	0.290	0.360
RC	0.100	0.190	0.290	0.360
RB	0.170	0.290	0.480	0.700
RE	0.150	0.260	0.380	0.590

Piston force and air consumption see page 9, dimensions see page 72- 75, order instructions see page 76

Dimensions – Basic Cylinder, Series R..., Ø 32 – 63 mm

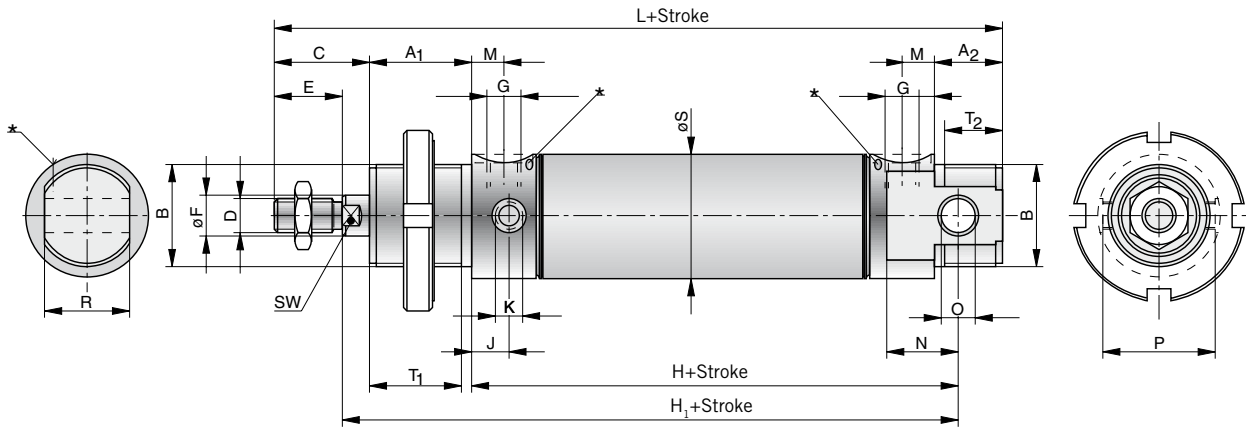

* adjustable end cushioning only for series R 5000

Dimensions – Basic Cylinder, Series RK..., Ø 32 – 63 mm

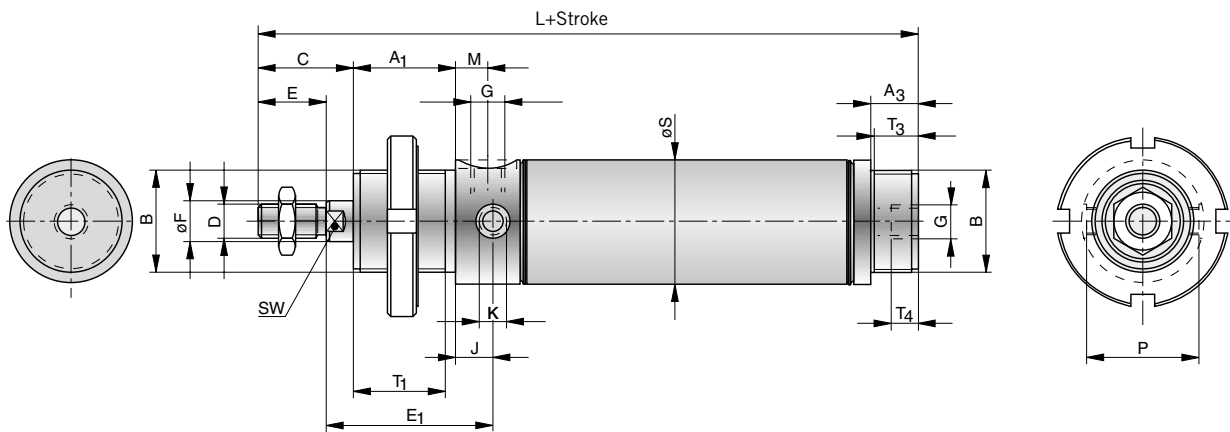

Dimension Table (mm) – Basic Cylinder, Series R..., RK..., RDU....

Cyl. Ø	A ₁	A ₂	A ₃	B	C	D	E	E ₁	ØF	G	H	H ₁ +Stroke	J	K	l _g +Stroke
32	30	19.5	14	M30x1.5	28	M10	20	49	12	G1/8	90.5	128.5	11	M8x1	83.5
40	35	21.5	16	M38x1.5	34	M12	24	57	16	G1/4	99.5	144.5	12	M10x1	89
50	38	25	18	M45x1.5	44	M16	32	63	20	G1/4	109.5	159.5	13	M12x1.5	93.5
63	38	24.5	18	M45x1.5	45	M16	32	64.5	20	G3/8	116.5	167.5	13.5	M14x1.5	101

Piston force and air consumption see page 9, mountings see page 74, 75, order instructions see page 76

Dimensions – Basic Cylinder with Through Piston Rod, Series RDU..., Ø 32 – 63 mm

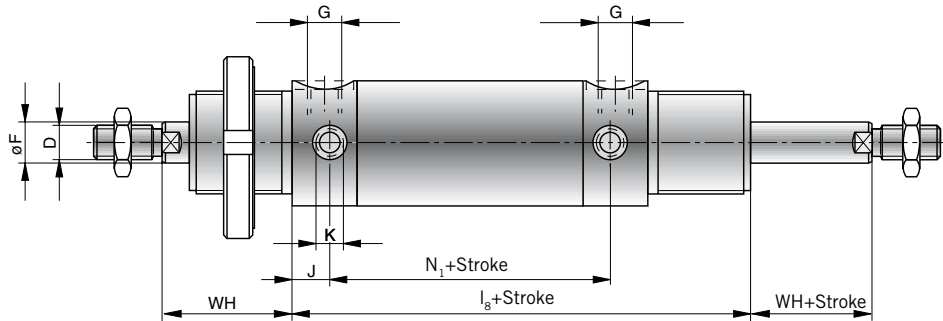

Cyl. Ø	L + Stroke R....	L + Stroke RK....	M	N	N_1 + Stroke	O	P	R_{h12}	ϕS	T_1	T_2	T_3	T_4	SW	WH	WH + Stroke
32	160.5	138.5	9.5	21	61.5	10	33	25	35	27	16.5	12	8	10	38	38
40	181.5	156.5	11	24	65	12	42	30	43	32	17.5	14	12	14	45	45
50	205.5	179.5	11	27	67.5	14	52	35	54	35	21	16	12	17	50	50
63	215.5	186.5	12.5	28	74	16	62	35	67	35	20.5	16	12	17	51	51

Accessories

 Piston Rod Eye Page 138	 Piston Rod Clevis Page 139	 Compensating Coupling Page 140	 Magnetic Switch Page 152													
---	--	--	--	--	--	--	--	--	--	--	--	--	--	--	--	--

Mountings – Series R..., RK..., Ø 32 – 63 mm

Foot Mounting Type RA2-..

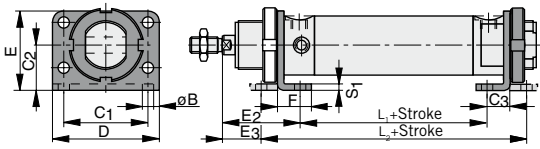

Material: steel, passivated

Dimension Table (mm) – Foot Mounting Type RA2

Cyl. Ø	ØB	C ₁	C ₂	C ₃	D	E	E ₂	E ₃	F	L ₁ +Stroke	L ₂ +Stroke	S ₁
32	6.6	52	28	14	66	49	48	24	21	63	111	4
										46.5*	94.5*	
40	9	60	33	20	80	58	60	25	30	61	131	5
										41.5*	111.5*	
50	9	70	40	20	90	70	64	30	30	70.5	138.5	6
										51.5*	119.5*	
63	9	76	45	20	96	80	65	31	30	80	148	6
										57.5*	125.5*	

* Dimensions in the grey fields are valid for series RK....

Pivot – Front Trunnion Mounting Type RE-..

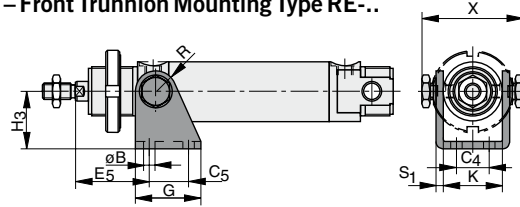

Material: steel, passivated

Dimension Table (mm) – Pivot – Front Trunnion Mounting Type RE

Cyl. Ø	ØB	C ₄	C ₅	E ₅	G	H ₃	K	R	S ₁	X
32	6.6	20	24	45	40	35	36.1	12	4	60
40	9	28	30	54	50	40	45.1	13	5	75
50	9	36	34	59	54	45	55.1	14	6	89
63	9	42	35	63.5	65	50	70.1	16	6	109

**Foot Mounting Type RA1-..
Flange Mounting Type RC-..**

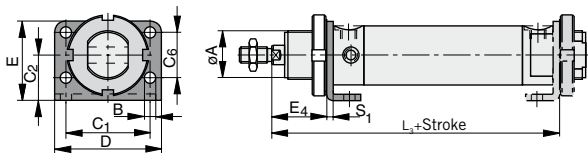

Material: steel, passivated

Dimension Table (mm) – Mounting RA1, RC

Cyl. Ø	ØA	B	C ₁	C ₂	C ₆	D	E	E ₄	L ₃ +Stroke	S ₁
32	30.1	6.6	52	28	28	66	49	34	125	4
									108.5*	
40	38.1	9	60	33	30	80	58	40	141	5
									121.5*	
50	45.1	9	70	40	40	90	70	44	154.5	6
									135.5*	
63	45.1	9	76	45	50	96	80	45	165	6
									142.5*	

* Dimensions are valid for series RK....

Pivot – Rear Trunnion Mounting Type RB-..

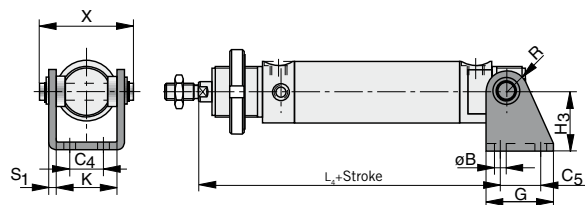

Material: steel, passivated

Dimension Table (mm) – Pivot Rear Trunnion Mounting Type RB

Cyl. Ø	ØB	C ₄	C ₅	G	H ₃	H	K	L ₄ +Stroke	R	S ₁	X
32	6.6	20	24	40	35	8	36.1	124.5	12	4	58
40	9	28	30	50	40	10	45.1	141.5	13	5	70
50	9	36	34	54	45	10	55.1	155.5	14	6	86
63	9	42	35	65	50	15	70.1	166.5	16	6	100

Mountings – Series RDU... (with through piston rod), Ø 32 – 63 mm

Foot mounting
(2 mounting brackets)

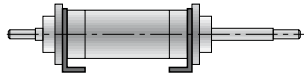

Material: steel, passivated

Foot mounting
(Flange mounting)

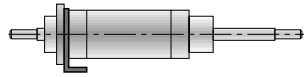

steel, passivated

Pivot – Front Trunnion Mounting

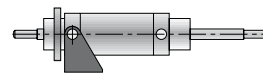

steel, passivated

Accessories

Piston Rod Eye



Page 138

Piston Rod Clevis



Page 139

Compensating
Coupling



Page 140

Magnetic Switch



Page 152

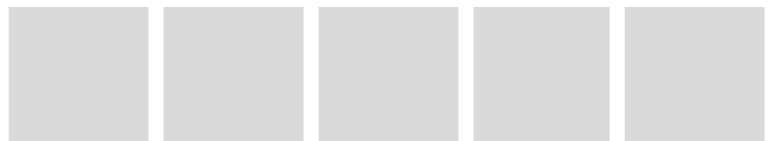

Piston force and air consumption see page 9, dimensions see page 72-74, order instructions see page 76

Order Instructions – Basic Cylinder *

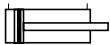
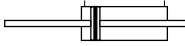
Series	Symbol	Piston-Ø	Order Instructions	
			Type	Order-No.
Double acting with adjustable end cushioning For contactless position sensing		32	R 5032/....*	PD46443-...
		40	R 5040/....	PD46445-....
		50	R 5050/....	PD46447-....
		63	R 5063/....	PD46449-....
Double acting without adjustable end cushioning For contactless position sensing		32	R 6032/....	PD46444-....
			RK 6032/....	PA58220-....
		40	R 6040/....	PD46446-....
			RK 6040/....	PA59140-....
		50	R 6050/....	PD46448-....
			RK 6050/....	PA60210-....
		63	R 6063/....	PD46450-....
			RK 6063/....	PA61150-....
With through piston rod Double acting without adjustable end cushioning For contactless position sensing		32	RDU 6032/....*	PD58270-...
		40	RDU 6040/....	PD59200-....
		50	RDU 6050/....	PD60270-....
		63	RDU 6063/....	PD61200-....

Complete type designation and order no. with stroke length (in mm)

(4-digit)

Standard stroke lengths: 0025, 0050, 0080, 0100, 0125, 0160, 0200, 0250, 0320, 0400, 0500 delivered preferably

* Magnetic switch mounting by band

Order Instructions – Mountings - Accessories

Description	Type	Order-No.			
		Ø32	Ø40	Ø50	Ø63
Foot mounting (1 mounting bracket)	RA 1-..	KK 29.302	KK 30.302	KK 31.302	KK 32.302
Foot mounting (standard version)	RA 2-..*	PD 25712	PD 25713	PD 25714	PD 25715
Flange mounting (1 mounting bracket)	RC- ..	KK 29.302	KK 30.302	KK 31.302	KK 32.302
Rear trunnion mounting	RB- ..	PD 40390	PD 40391	PD 40392	PD 40393
Front trunnion mounting	RE-..	PD 40394	PD 40395	PD 40396	PD 40397

Complete type designation with piston-Ø

Ordering example: RA-32 KK 29.302

* consists of 2 mounting brackets and 1 groove nut

ARA
PNEUMATIK
53-012 Wrocław tel. 71 364 72 80
ul. Wyciągowa 38 fax 71 364 72 83
www.arapneumatik.pl

