

Contents

Version	Actuation	Page		
		Characteristics	Dimensions	Order Instructions Overview
2 x 3/2 Way Valves	pneumatic	16,17	18, 20	29
	electric	16,17	19, 21	29
5/2 Way Valves	pneumatic	16,17	22, 23	30
	electric	16,17	24, 25	30
5/3 Way Valves	pneumatic	16,17	22, 23, 26, 27	31
	electric	16,17	24, 25, 28	31
Valve Manifold Assemblies		16,17	32-35	30
Valve Islands		16,17	37, 38	36
RPS-Manifolds			40	40
Accessories			41, 42	41, 42

Compact Valves

With threaded ports

*Series S10..-1/8
Series S10..-1/4*

or

with push-in connections

*Series S10..-Q6
Series S10..-Q8*

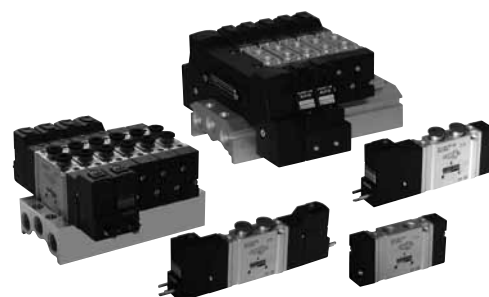

Overview

Description	Actuation	Port		Versions			Middle Position Functions		
		G1/8 Q6	G1/4 Q8	Standard	with biased position	with external pilot air	middle position closed	middle position vented	middle position pressurized
2x3/2 Way Valves normally closed normally open	pneumatic permanent signal ⁽¹⁾	■	■	■	–	–	–	–	–
	electric permanent signal ⁽¹⁾	■	■	■	–	■	–	–	–
5/2 Way Valves	pneumatic permanent signal ⁽²⁾	■	■	■	–	–	–	–	–
	pneumatic impulse	■	■	■	■	–	–	–	–
	electric permanent signal ⁽²⁾	■	■	■	–	■	–	–	–
	electric impulse	■	■	■	■	■	–	–	–
5/3 Way Valves	pneumatic permanent signal	■	■	■	–	–	■	■	■
	electric permanent signal	■	■	■	–	■	■	■	■

⁽¹⁾ Air spring return

⁽²⁾ Return by either mechanical spring or air spring (see Order Instructions, page 29-31)

Note:

S10 Series valves are normally supplied without connector

– please include in Order Code or order separately (see Order Instructions)



Characteristics – Series S10..-1/8, S10..-1/4, S10..-Q6, S10..-Q8 (Single Valves) and IM10 (Valve Islands)

Characteristics	Symbol	Unit	Description	
Version			with threaded ports	with push-in connections (version Q6, Q8)
Actuation			Pneumatic	electrically pilot actuated
General Features				
System			Spool Valve	
Mounting			2 Screws M3 (S10..-1/8, S10..-Q6), 2 Screws M4 (S10..-1/4, S10..-Q8)	
Tube connection			Thread	Threaded ports and push-in connections
Port size				
– Series S10..-1/8, S10..-Q6			G1/8	Port 1, 3, 5: G1/8, Port 2, 4: push-in connection OD 6 mm
– Series S10..-1/4, S10..-Q8			Port 1, 2, 4: G1/4 Port 3, 5: G1/8	Port 1: G1/4 – Port 3, 5: G1/8 Port 2, 4: push-in connection OD 8 mm
Nominal diameter		mm	6	
Weight (mass)		kg	See page 18, 20, 22, 26	
Installation				
Ambient temperature range	$T_{min./max.}$	°C	-5 to +50	Note: for use below freezing point please consult us
Medium temperature range	$T_{min./max.}$	°C	0 to +50	
Vibration resistance / vibration		G	Max. 5	
Impact strength/shock		G	Max. 30	
Medium			Filtered compressed air (5µm)	
Lubrication			With or without oil mist lubrication (We recommend mineral oil type VG 32 to ISO 3448)	
Pneumatic Characteristics				
Nominal pressure	$p_{min./max.}$	bar	6	
Operating pressure range				
– permanent signal version	$p_{min./max.}$	bar	2 – 8 (5/2 way version), 3 – 8 (5/3 and 2x3/2 way version)	
– impulse version	$p_{min./max.}$	bar	1.5 – 8 (5/2 way version)	
– with external pilot air	$p_{min./max.}$	bar	-0.9 – 8 (5/2 way version), -0,9 – 8 (5/3 and 2x3/2 way version)	
Nominal flow				
Series – S10..-1/8, S10..-Q6	QN	l/min	5/2 way version 650, 5/3 way version 550, 2x3/2 way version 400	
Series – S10..-1/4, S10..-Q8	QN	l/min	5/2 way version 950, 5/3 way version 850, 2x3/2 way version 850	

Characteristics	Symbol	Unit	Description	
Actuation				
Pneumatic			Direct	
– actuation pressure range				
– permanent signal version	$p_{st \text{ min./max.}}$	bar	2 – 8 (5/2 way version), 3 – 8 (5/3 and 2x3/2 way version)	
– impulse version	$p_{st \text{ min./max.}}$	bar	1.5 – 8 (5/2 way version)	
Electrical single Valves S10			Electrically pilot actuated	
Voltage types			Alternating current (50/60Hz)	Direct current
Nominal voltage				
– standard version	Un	V	230, 110, 48 ±10%	24, 12 ±10% other voltages available on request
Power consumption, switching				
– standard version		VA (W)	ca. 2.8	1.1
Power consumption, holding				
– standard version		VA (W)	ca. 2	1.1
Duty cycle	ED	%	100	
Electrical protection		IP	IP 65 to DIN 40050 (applies only to solenoid with plug)	
Connection			Connector to DIN EN 175301-803 form C (¹)	
Electrical valve islands IM10			Electrically pilot actuated	
Nominal voltage	Un	V	24, 12	
Voltage types			Direct current	
Power consumption, switching			VA (W)	1.1
Power consumption, holding			VA (W)	1.1
Duty cycle	ED	%	100	
Electrical protection		IP	IP 65 to DIN 40050 (Applies only to the electrically part in combination with sub-D connector, IP 65)	
Connection			D-Sub connector 25pin	
Switching indicator			LED	
Number of outputs			max. 22, max. 18 (monostable)	

(¹ Solenoid also available with cable (length 1m) – see Order Instructions)

2 x 3/2 Way Valves Series S10

G1/8
and
Push-In Connections
OD 6 mm

Actuation systems:
– Pneumatic
– Electrical pilot actuated

Versions:
– 2x normally closed
– 2x normally open
– 1x normally closed and
 1x normally open
– With external pilot air

Accessories:
– Adapter plate for direct
 mounting on
 HOERBIGER-ORIGA
 profile-type cylinders
– Mounting bracket

For further information see
page 41, 42

Weight (mass) kg

Description	Type	Weight (mass)
Pneumatic, by permanent signal	S10 361R..-1/8	0.063 kg
Electrical, by permanent signal	S10 381R..-1/8	0.089 kg
Pneumatic, by permanent signal	S10 361R..-Q6	0.070 kg
Electrical, by permanent signal	S10 381R..-Q6	0.097 kg

2 x 3/2 Way Valve, pneumatically actuated – threaded version Type: S10 361..-1/8

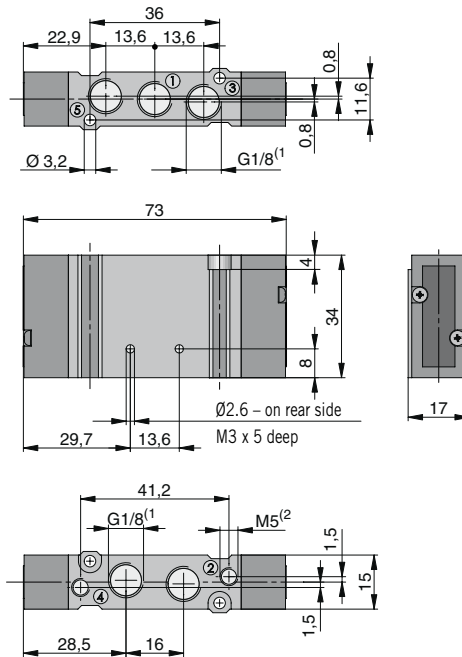

(1) thread depth 7.5 mm
(2) thread depth 5 mm

2x 3/2 Way Valve, pneumatically actuated – version with push-in connection Type: S10 361..-Q6

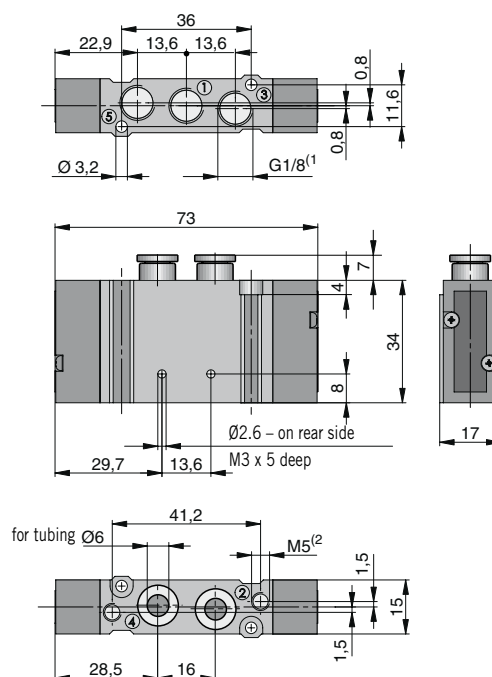

(1) thread depth 7.5 mm
(2) thread depth 5 mm



2 x 3/2 Way Valve, electrically actuated (permanent signal) – threaded version
Type: S10 381R..-1/8

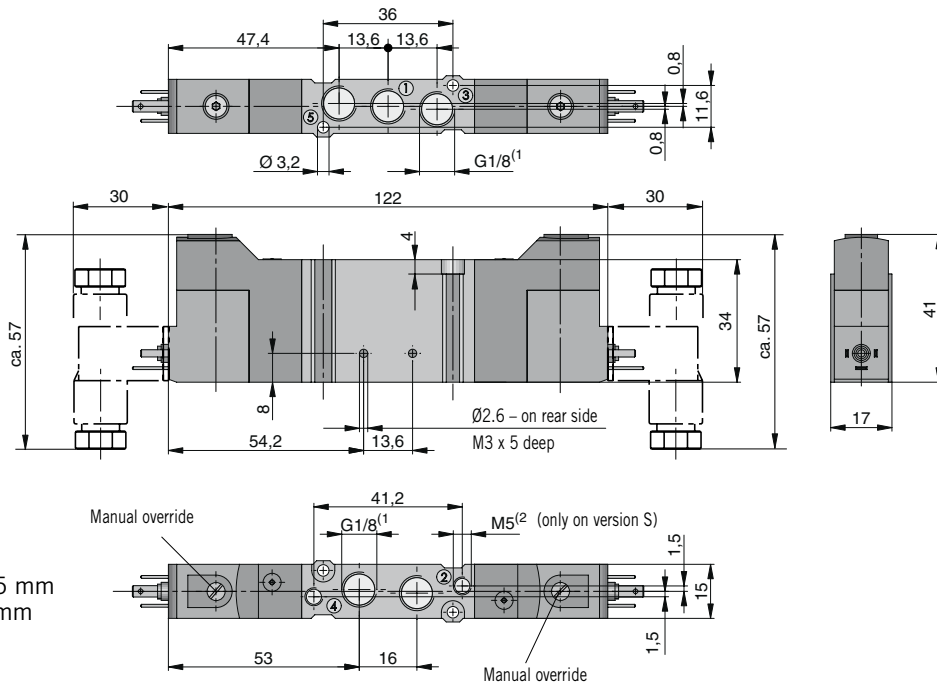

2 x 3/2 Way Valve, electrically actuated (permanent signal) – version with push-in connections
Type: S10 381R..-Q6

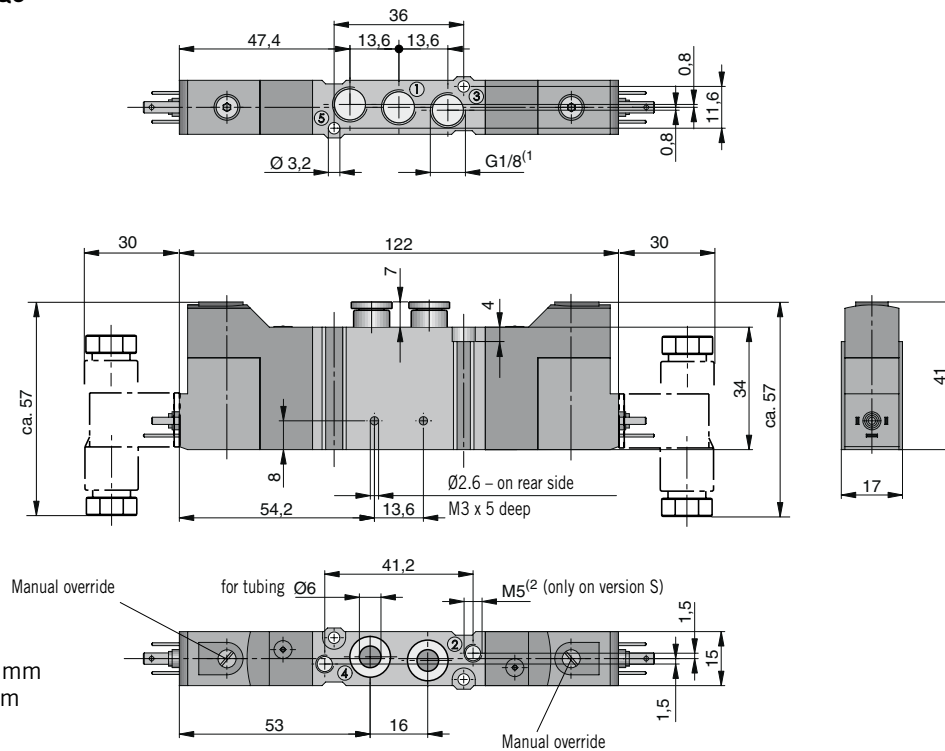

For valve manifolds see page 32-34, for RPS manifolds see page 38, for mounting bracket see page 41, for adapter plate see page 41

Dimensions in mm

2 x 3/2 Way Valves Series S10

G1/4
and Push-In
Connections
OD 8 mm

Actuation systems:
– Pneumatic
– Electrical pilot operated

Versions:
– 2x normally closed
– 2x normally open
– 1x normally closed and
1x normally open
– With external pilot air

Accessories:
– Adapter plate for direct
mounting on
Parker -ORIGA
profile-type cylinders
– Mounting brackets

For further information see
page 41, 42

Weight (mass) kg

Description	Type	Gew. (mass)
Pneumatic, by permanent signal	S10 361R..-1/4	0.094 kg
Electrical, by permanent signal	S10 381R..-1/4	0.123 kg
Pneumatic, by permanent signal	S10 361R..-Q8	0.116 kg
Electrical, by permanent signal	S10 381R..-Q8	0.147 kg

2 x 3/2 Way Valve, pneumatically actuated – threaded version Type: S10 361..-1/4

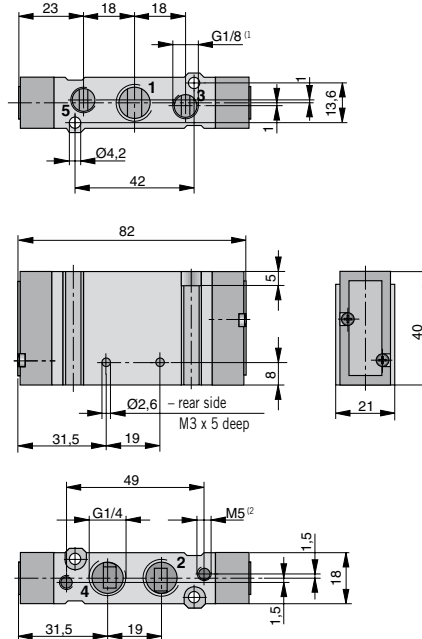

2 x 3/2 Way Valve, pneumatically actuated – version with push-in connections Type: S10 361..-Q8

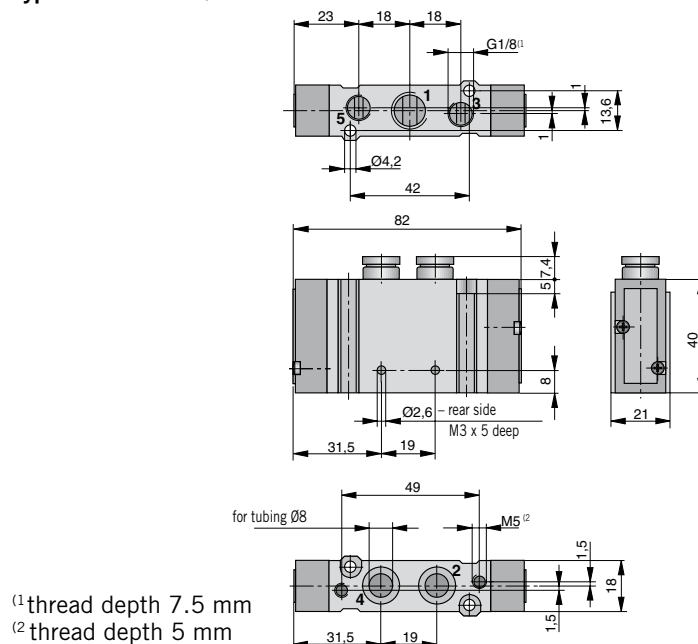

2 x 3/2 Way Valve, electrically actuated (permanent signal) – threaded version
Type: S10 381R..-1/4

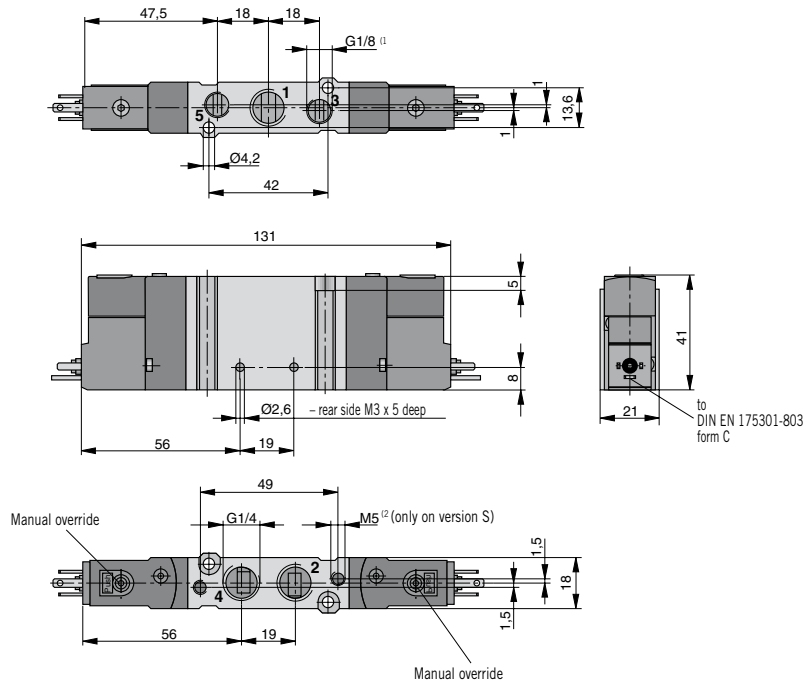

2 x 3/2 Way Valve, electrically actuated (permanent signal) – version with push-in connections

Type: S10 381R..-Q8

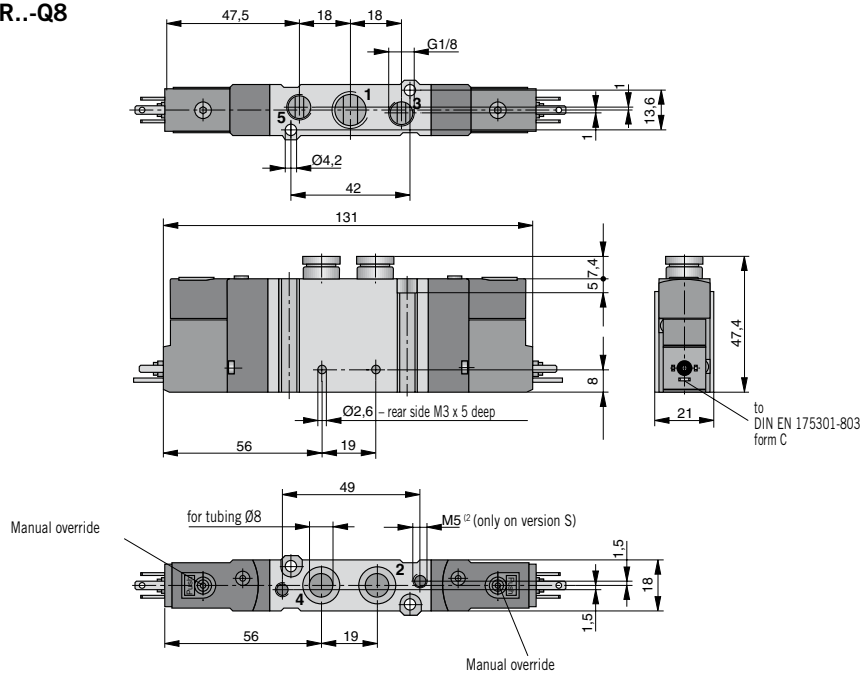

¹ thread depth 7.5 mm
² thread depth 5 mm

For RPS manifolds see page Page 39, for mounting bracket see page 41,
 for adapter plate see page 41

Dimensions in mm

5/2 and 5/3 Way Valves Series S10

G1/8 and
Push-In Connections
OD 6 mm

Actuation systems:
– Pneumatic
– Electrical, pilot operated

Versions:
– With biased position
– With external pilot air

Accessories:
– Adapter plate for direct
mounting on
Parker -ORIGA
profile-type cylinders
– Mounting bracket

For further information see
page 41, 42

Weight (mass) kg

Description	Type	Weight (mass)
Pneumatic, by permanent signal	S10 561R..-1/8	0.063 kg
Pneumatic, by impulse	S10 561(562)-1/8	0.063 kg
Electrical, by permanent signal	S10 581R..-1/8	0.076 kg
Electrical, by impulse	S10 581(582)-1/8	0.089 kg
Pneumatic, by permanent signal	S10 561R..-Q6	0.070 kg
Pneumatic, by impulse	S10 561(562)-Q6	0.070 kg
Electrical, by permanent signal	S10 581R..-Q6	0.083 kg
Electrical, by impulse	S10 581(582)-Q6	0.097 kg

5/2 and 5/3 Way Valve, pneumatically actuated – threaded version
Type: S10 561..-1/8, S10 562..-1/8, S10 561RF.-1/8

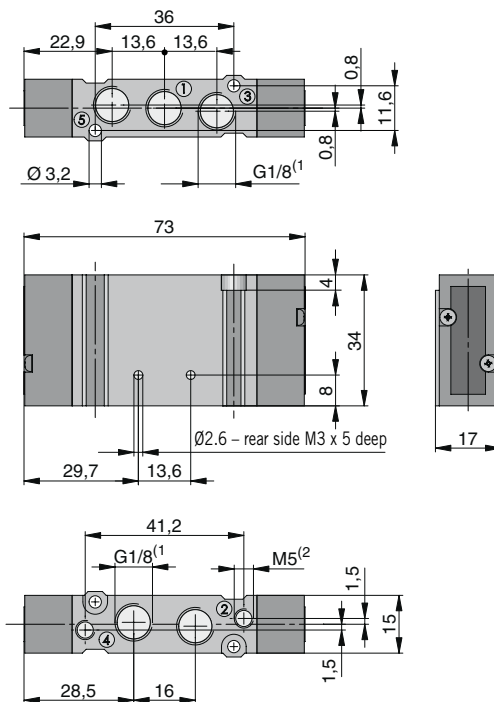

⁽¹⁾ thread depth 7.5 mm
⁽²⁾ thread depth 5 mm



ARA®

PNEUMATIK

53-012 Wrocław tel. 71 364 72 82
ul. Wysięgowa 38 fax 71 364 72 83

www.arapneumatik.pl



5/2 Way Valve, electrically actuated (permanent signal) – threaded version
Type: S10 581...-1/8

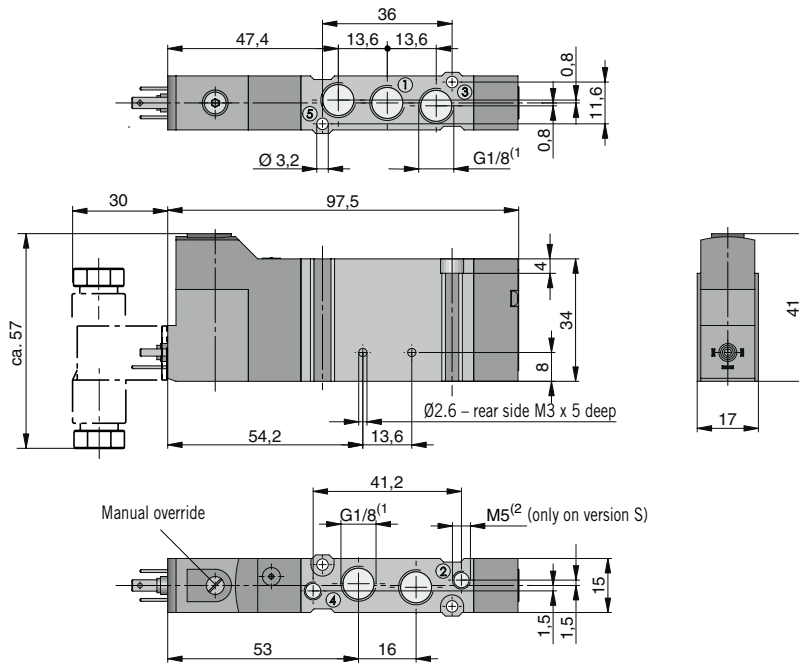

5/2 Way Valve, electrically actuated (permanent signal) – version with push-in connections
Type: S10 581...-Q6

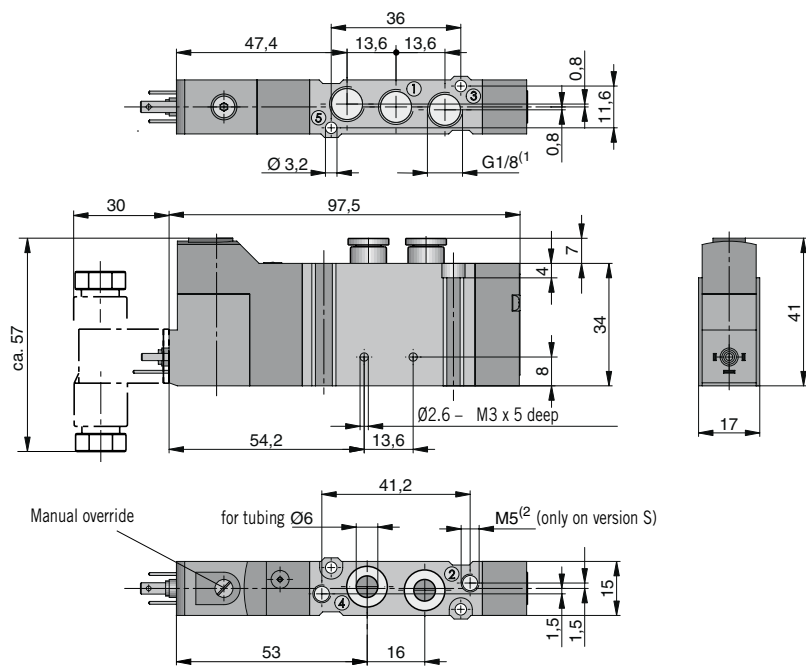

For valve manifolds see page 32-34, for RPS manifolds see page 38, for mounting bracket see page 41,
 for adapter plate see page 41

Dimensions in mm

5/2 Way Valve, electrically actuated (impulse) – threaded version, Type: S10 581-1/8, S10 582-1/8
5/3 Way Valve, electrically actuated (permanent signal) – threaded version, Type: S10 581RF-1/8

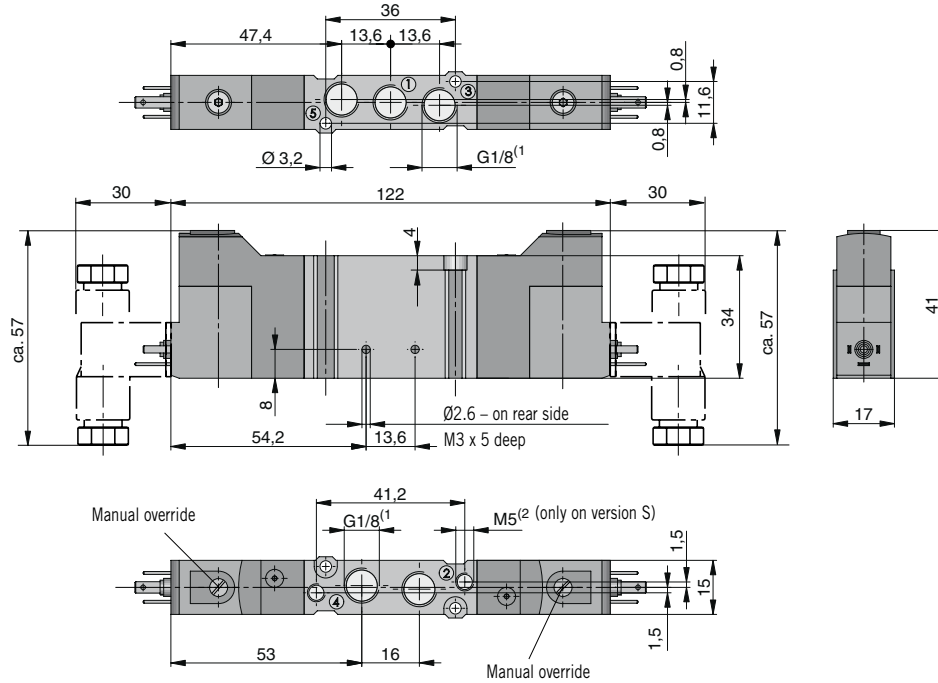

5/2 Way Valve, electrically actuated (impulse) – version with push-in connections, Type: S10 581-Q6, S10 582-Q6
5/3 Way Valve, electrically actuated (permanent signal) – version with push-in connections, Type: S10 581RF-Q6

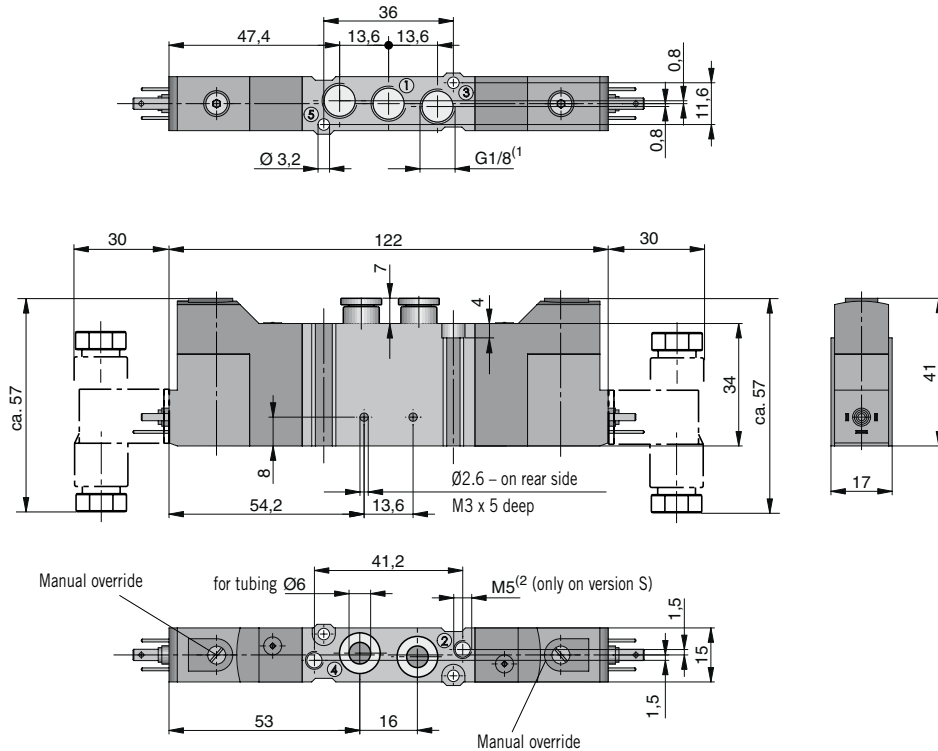

For valve manifolds see page 32, 34, for RPS manifolds see page 38, for mounting bracket see page 41, for adapter plate see page 41

Dimensions in mm

5/2 and 5/3 Way Valves Series S10

G1/4 and
Push-In Connections
OD 8 mm

Actuation systems:

- Pneumatic
- Electrical pilot actuated

Versions:

- With biased position
- With external pilot air

Accessories:

- Adapter plate for direct mounting on Parker Origa profile-type cylinders
- Mounting bracket

For further information see page 41, 42

Weight (mass) kg

Description	Type	Weight (mass)
Pneumatic, by permanent signal	S10 561R..-1/4	0.097 kg
Pneumatic, by impulse	S10 561(562)-1/4	0.097 kg
Electrical, by permanent signal	S10 581R..-1/4	0.110 kg
Electrical, by impulse	S10 581(582)-1/4	0.125 kg
Pneumatic, by permanent signal	S10 561R..-Q8	0.118 kg
Pneumatic, by impulse	S10 561(562)-Q8	0.118 kg
Electrical, by permanent signal	S10 581R..-Q8	0.132 kg
Electrical, by impulse	S10 581(582)-Q8	0.147 kg

5/2 and 5/3 Way Valve, pneumatically actuated, threaded version Type: S10 561..-1/4, S10 562..-1/4, S10 561RF.-1/4

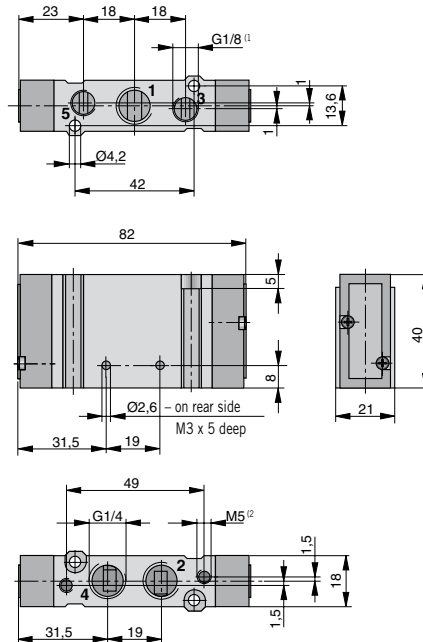

- ⁽¹⁾ thread depth 7.5 mm
⁽²⁾ thread depth 5 mm

5/2 and 5/3 Way Valve, pneumatically actuated, version with push-in connections Type: S10 561..-Q8, S10 562..-Q8, S10 561RF.-Q8

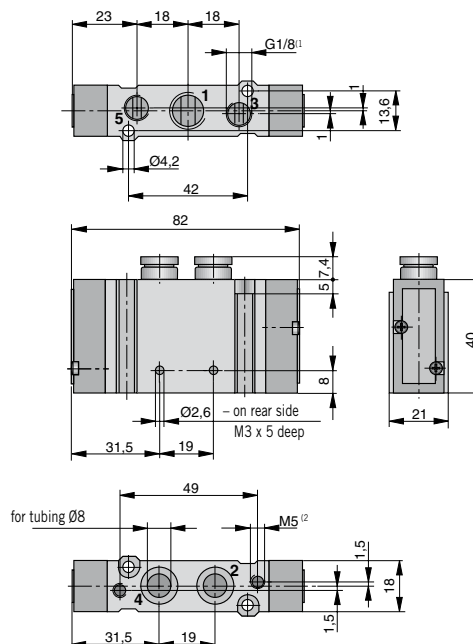

- ⁽¹⁾ thread depth 7.5 mm
⁽²⁾ thread depth 5 mm

5/2 Way Valve, electrically actuated (impulse) – threaded version Type: S10 581-1/4, S10 582-1/4
5/3 Way Valve, electrically actuated (permanent signal) – threaded version Type: S10 581RF-1/4

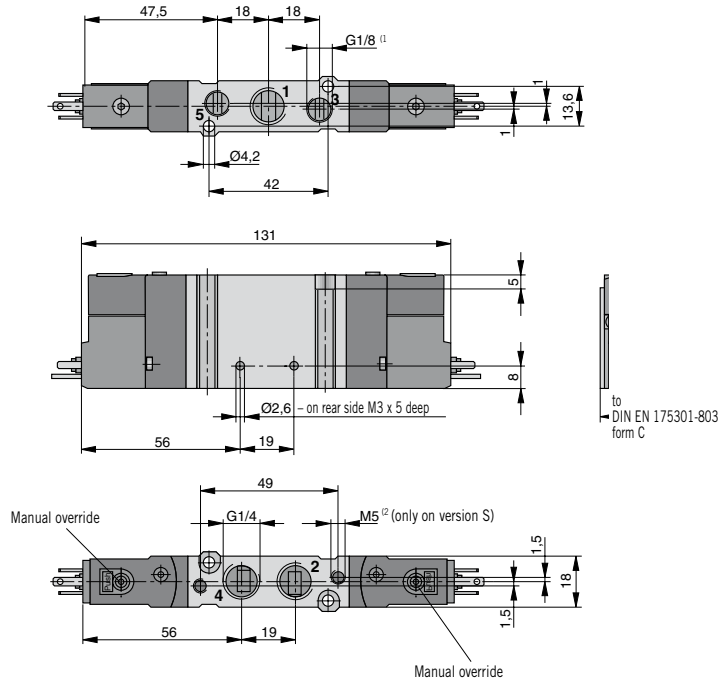

⁽¹⁾ thread depth 7.5 mm
⁽²⁾ thread depth 5 mm

5/2 Way Valve, electrically actuated (impulse) – version with Push-In Connections Type: S10 581-Q6, S10 582-Q8
5/3 Way Valve, electrically actuated (permanent signal) – version with Push-In Connections Type: S10 581RF-Q8

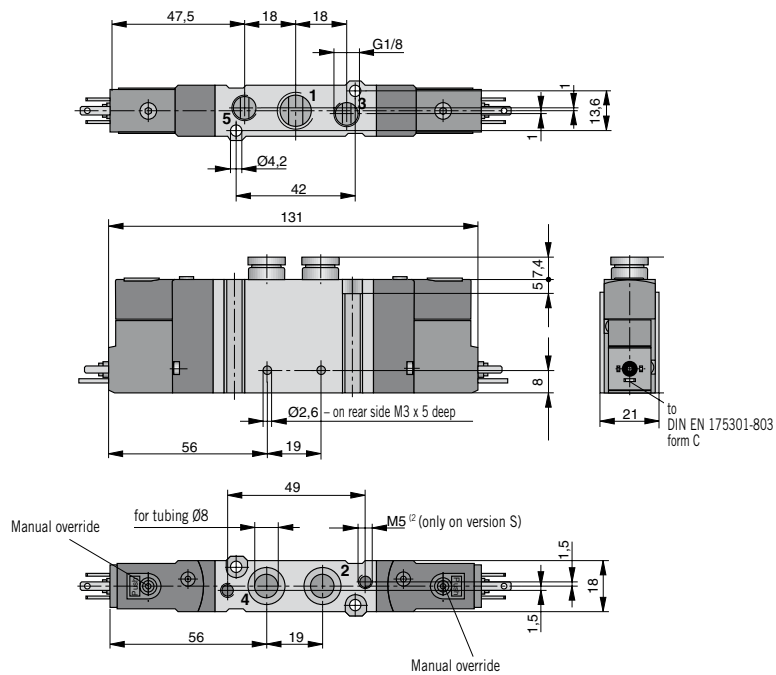

⁽¹⁾ thread depth 7.5 mm
⁽²⁾ thread depth 5 mm

For RPS manifolds see page 39, for mounting bracket see page 41,
 for adapter plate see page 41

Dimensions in mm

Order Instructions – 2 x 3/2 Way Valves, Series S10..-1/8, S10..-1/4, S10..-Q6, S10..-Q8

Actuation System	Symbol	Connections		Order Instructions		Page
		Thread	Push-In	Type	Order No.	
Pneumatic by permanent signal		G1/8	–	S10361R2G-1/8	PA 10417	18
		–	ODØ 6mm	S10361R2G-Q6	PA 10447	18
		G1/4	–	S10361R2G-1/4	PA 10537	22
		–	ODØ 8mm	S10361R2G-Q8	PA 10567	23
		G1/8	–	S10361R20-1/8	PA 10418	18
		–	ODØ 6mm	S10361R20-Q6	PA 10448	18
		G1/4	–	S10361R20-1/4	PA 10538	22
		–	ODØ 8mm	S10361R20-Q8	PA 10568	23
		G1/8	–	S10361RGO-1/8	PA 10419	20
		–	ODØ 6mm	S10361RGO-Q6	PA 10449	18
		G1/4	–	S10361RGO-1/4	PA 10539	22
		–	ODØ 8mm	S10361RGO-Q8	PA 10569	23
Electrical by permanent signal		G1/8	–	S10381R2G-1/8-□33-□	PA 10404-□33-□	19
		–	ODØ 6mm	S10381R2G-Q6-□33-□	PA 10434-□33-□	19
		G1/4	–	S10381R2G-1/4-□33-□	PA 10524-□33-□	21
		–	ODØ 8mm	S10381R2G-Q8-□33-□	PA 10554-□33-□	21
		G1/8	–	S10381R20-1/8-□33-□	PA 10406-□33-□	19
		–	ODØ 6mm	S10381R20-Q6-□33-□	PA 10436-□33-□	19
		G1/4	–	S10381R20-1/4-□33-□	PA 10526-□33-□	21
		–	ODØ 6mm	S10381R20-Q8-□33-□	PA 10556-□33-□	21
		G1/8	–	S10381RGO-1/8-□33-□	PA 10408-□33-□	19
		–	ODØ 6mm	S10381RGO-Q6-□33-□	PA 10438-□33-□	19
		G1/4	–	S10381RGO-1/4-□33-□	PA 10528-□33-□	21
		–	ODØ 8mm	S10381RGO-Q8-□33-□	PA 10558-□33-□	21
Electrical by permanent signal with external pilot air		G1/8	–	S10381S-R2G-1/8-□33-□	PA 10405-□33-□	19
		–	ODØ 6mm	S10381S-R2G-Q6-□33-□	PA 10435-□33-□	19
		G1/4	–	S10381S-R2G-1/4-□33-□	PA 10525-□33-□	21
		–	ODØ 8mm	S10381S-R2G-Q8-□33-□	PA 10555-□33-□	21
		G1/8	–	S10381S-R20-1/8-□33-□	PA 10407-□33-□	19
		–	ODØ 6mm	S10381S-R20-Q6-□33-□	PA 10437-□33-□	19
		G1/4	–	S10381S-R20-1/4-□33-□	PA 10527-□33-□	21
		–	ODØ 8mm	S10381S-R20-Q8-□33-□	PA 10557-□33-□	21
		G1/8	–	S10381S-RGO-1/8-□33-□	PA 10409-□33-□	19
		–	ODØ 6mm	S10381S-RGO-Q6-□33-□	PA 10439-□33-□	19
		G1/4	–	S10381S-RGO-1/4-□33-□	PA 10529-□33-□	21
		–	ODØ 6mm	S10381S-RGO-Q8-□33-□	PA 10559-□33-□	21

**Solenoid version/
voltage**

- for connector
- 00 without solenoid
- 01 12 V DC
- 02 24 V DC
- 04 48 V DC
- 07 110 V DC
- 50 12 V AC
- 51 24 V AC
- 55 48 V AC
- 57 110 V AC
- 61 230 V AC
- with cable (length 1m)
- 41 12 V DC
- 42 24 V DC
- 71 12 V AC
- 72 24 V AC

Other voltages available on request

Notes on ordering:

All electrically actuated valves are supplied **without** connector as standard.

– **please include this in Order No. or order it separately (see Order Instructions).**

For electrically actuated valves please complete the Type Designation and Order No. with the order codes.

Example:

3/2 Way Valve, threaded version G1/8, electrically actuated, with spring return, normally closed, voltage 12 V DC, with standard connector

Order Instructions:

S10381R2G-1/8-0133-88

PA 10404-0133-88

**Variants
connector**

- 00 without connector *
- 88 standard connector 15mm
- 89 230 V AC with LED and protective circuit
- 92 24 V DC with LED and protective circuit

* Standard version

ARA[®]
PNEUMATIK

53-012 Wrocław tel. 71 364 72 82
ul. Wyciągowa 38 fax 71 364 72 83

www.arapneumatik.pl



Order Instructions – 5/2 Way Valves, Series S10..-1/8, S10..-1/4, S10..-Q6, S10..-Q8

Actuation System	Symbol	Connections		Order Instructions		Page	
		Thread	Push-In Connections	Type	Order No.		
Pneumatic by permanent signal		G1/8	–	S10 561RF-1/8	PA 10410	22, 23	
		–	ODØ 6mm	S10 561RF-Q6	PA 10440	22, 23	
		G1/4	–	S10 561RF-1/4	PA 10530	26	
	– with biased position		–	ODØ 8mm	S10 561RF-Q8	PA 10560	26
			G1/8	–	S10 561R-1/8	PA 10411	22, 23
			–	ODØ 6mm	S10 561R-Q6	PA 10441	22, 23
Pneumatic by impulse		G1/4	–	S10 561R-1/4	PA 10531	26	
		–	ODØ 8mm	S10 561R-Q8	PA 10561	26	
		G1/8	–	S10 561-1/8	PA 10412	22, 23	
	– with biased position		–	ODØ 6mm	S10 561-Q6	PA 10442	22, 23
			G1/4	–	S10 561-1/4	PA 10532	26
			–	ODØ 8mm	S10 561-Q8	PA 10562	26
Electrical by permanent signal		G1/8	–	S10 562-1/8	PA 10413	22, 23	
		–	ODØ 6mm	S10 562-Q6	PA 10443	22, 23	
		G1/4	–	S10 562-1/4	PA 10533	26	
	– with biased position		–	ODØ 8mm	S10 562-Q4	PA 10563	26
			G1/8	–	S10 581RF-1/8-□33-□	PA 10390-□33-□	24
			–	ODØ 6mm	S10 581RF-Q6-□33-□	PA 10420-□33-□	24
Electrical by impulse		G1/4	–	S10 581RF-1/4-□33-□	PA 10510-□33-□	27	
		–	ODØ 8mm	S10 581RF-Q8-□33-□	PA 10540-□33-□	27	
		G1/8	–	S10 581R-1/8-□33-□	PA 10392-□33-□	24	
	– with biased position		–	ODØ 6mm	S10 581R-Q6-□33-□	PA 10422-□33-□	24
			G1/4	–	S10 581R-1/4-□33-□	PA 10512-□33-□	27
			–	ODØ 8mm	S10 581R-Q8-□33-□	PA 10542-□33-□	27
Electrical by permanent signal with external pilot air		G1/8	–	S10 581S-RF-1/8-□33-□	PA 10391-□33-□	24	
		–	ODØ 6mm	S10 581S-RF-Q6-□33-□	PA 10421-□33-□	24	
		G1/4	–	S10 581S-RF-1/4-□33-□	PA 10511-□33-□	27	
	– with biased position		–	ODØ 8mm	S10 581S-RF-Q8-□33-□	PA 10541-□33-□	27
			G1/8	–	S10 581S-R-1/8-□33-□	PA 10393-□33-□	24
			–	ODØ 6mm	S10 581S-R-Q6-□33-□	PA 10423-□33-□	24
Electrical by impulse with external pilot air		G1/4	–	S10 581S-R-1/4-□33-□	PA 10513-□33-□	27	
		–	ODØ 8mm	S10 581S-R-Q8-□33-□	PA 10543-□33-□	27	
		G1/8	–	S10 581-1/8-□33-□	PA 10394-□33-□	25	
	– with biased position		–	ODØ 6mm	S10 581-Q6-□33-□	PA 10424-□33-□	25
			G1/4	–	S10 581-1/4-□33-□	PA 10514-□33-□	27
			–	ODØ 8mm	S10 581-Q8-□33-□	PA 10544-□33-□	27
Electrical by impulse with external pilot air		G1/8	–	S10 582-1/8-□33-□	PA 10396-□33-□	25	
		–	ODØ 6mm	S10 582-Q6-□33-□	PA 10426-□33-□	25	
		G1/4	–	S10 582-1/4-□33-□	PA 10516-□33-□	27	
	– with biased position		–	ODØ 8mm	S10 582-Q8-□33-□	PA 10546-□33-□	27
			G1/8	–	S10 581S-1/8-□33-□	PA 10395-□33-□	25
			–	ODØ 6mm	S10 581S-Q6-□33-□	PA 10425-□33-□	25
Electrical by impulse with external pilot air		G1/4	–	S10 581S-1/4-□33-□	PA 10515-□33-□	27	
		–	ODØ 8mm	S10 581S-Q8-□33-□	PA 10545-□33-□	27	
		G1/8	–	S10 582S-1/8-□33-□	PA 10397-□33-□	25	
	– with biased position		–	ODØ 6mm	S10 582S-Q6-□33-□	PA 10427-□33-□	25
			G1/4	–	S10 582S-1/4-□33-□	PA 10517-□33-□	27
			–	ODØ 8mm	S10 582S-Q8-□33-□	PA 10547-□33-□	27

Supplements on types and order no. see page 29

Notes on ordering:

All electrically actuated valves are supplied **without** connector as standard.

– **please include this in Order No. or order it separately (see Order Instructions).**

For electrically actuated valves please complete the Type Designation and Order No. with the order codes.

Example:

5/2 Way Valve, Push-In Connections, electrically actuated, with spring return, voltage 24 V DC, with standard connector.

Order Instructions:

S10 581RF-Q6-0233-88

PA 10420-0233-88

Order Instructions – 5/3 Way Valves, Series S10...-1/8, S10...-1/4, S10...-Q6, S10...-Q8

Actuation System	Symbol	Connections		Order Instructions		Page	
		Thread	Push-In	Type	Order No.		
Pneumatic permanent signal		G1/8	–	S10 561RFG-1/8	PA 10414	23	
		–	ODØ 6mm	S10 561RFG-Q6	PA 10444	23	
		G1/4	–	S10 561RFG-1/4	PA 10534	26	
		–	ODØ 8mm	S10 561RFG-Q8	PA 10564	26	
		G1/8	–	S10 561RFE-1/8	PA 10415	23	
		–	ODØ 6mm	S10 561RFE-Q6	PA 10445	23	
		G1/4	–	S10 561RFE-1/4	PA 10535	26	
		–	ODØ 8mm	S10 561RFE-Q8	PA 10565	26	
		G1/8	–	S10 561RFB-1/8	PA 10416	23	
		–	ODØ 6mm	S10 561RFB-Q6	PA 10446	23	
		G1/4	–	S10 561RFB-1/4	PA 10536	26	
		–	ODØ 8mm	S10 561RFB-Q8	PA 10566	26	
Electrical permanent signal		G1/8	–	S10 581RFG-1/8-□33-□	PA 10398-□33-□	25	
		–	ODØ 6mm	S10 581RFG-Q6-□33-□	PA 10428-□33-□	25	
		G1/4	–	S10 581RFG-1/4-□33-□	PA 10518-□33-□	28	
		–	ODØ 8mm	S10 581RFG-Q8-□33-□	PA 10548-□33-□	28	
		G1/8	–	S10 581RFE-1/8-□33-□	PA 10400-□33-□	25	
		–	ODØ 6mm	S10 581RFE-Q6-□33-□	PA 10430-□33-□	25	
		G1/4	–	S10 581RFE-1/4-□33-□	PA 10520-□33-□	28	
		–	ODØ 8mm	S10 581RFE-Q8-□33-□	PA 10550-□33-□	28	
		G1/8	–	S10 581RFB-1/8-□33-□	PA 10402-□33-□	25	
		–	ODØ 6mm	S10 581RFB-Q6-□33-□	PA 10432-□33-□	25	
		G1/4	–	S10 581RFB-1/4-□33-□	PA 10522-□33-□	28	
		–	ODØ 8mm	S10 581RFB-Q8-□33-□	PA 10552-□33-□	28	
	Electrical permanent signal with external pilot air		G1/8	–	S10 581S-RFG-1/8-□33-□	PA 10399-□33-□	25
			–	ODØ 6mm	S10 581S-RFG-Q6-□33-□	PA 10429-□33-□	25
			G1/4	–	S10 581S-RFG-1/4-□33-□	PA 10519-□33-□	28
			–	ODØ 8mm	S10 581S-RFG-Q8-□33-□	PA 10549-□33-□	28
			G1/8	–	S10 581S-RFE-1/8-□33-□	PA 10401-□33-□	25
			–	ODØ 6mm	S10 581S-RFE-Q6-□33-□	PA 10431-□33-□	25
		G1/4	–	S10 581S-RFE-1/4-□33-□	PA 10521-□33-□	28	
		–	ODØ 8mm	S10 581S-RFE-Q8-□33-□	PA 10551-□33-□	28	
		G1/8	–	S10 581S-RFB-1/8-□33-□	PA 10403-□33-□	25	
		–	ODØ 6mm	S10 581S-RFB-Q6-□33-□	PA 10433-□33-□	25	
		G1/4	–	S10 581S-RFB-1/4-□33-□	PA 10523-□33-□	28	
		–	ODØ 8mm	S10 581S-RFB-Q8-□33-□	PA 10553-□33-□	28	

Solenoid version/ voltage
– for connector
00 without solenoid
01 12 VDC
02 24 VDC
04 48 VDC
07 110 VDC
50 12 VAC
51 24 VAC
55 48 VAC
57 110 VAC
61 230 VAC
– with cable (length 1m)
41 12 VDC
42 24 VDC
71 12 VAC
72 24 VAC

Other voltages available on request

Notes on ordering:

all electrically actuated valves are supplied **without** connector as standard
 – **please include this in Order No. or order it separately (see Order Instructions).**

For electrically actuated valves please complete the Type Designation and Order No. with the order codes.

Example:

5/3 Way Valve, middle position closed, Push-In Connections, electrically actuated, with spring return, voltage 230V AC, without connector.

Order Instructions:

S10 581RFG-Q6-6133-00

PA 10428-6133-00

Variants connector

00 without connector *
88 standard connector 15mm
89 230 V AC with LED and protective circuit
92 24 VDC with LED and protective circuit

* Standard version

Valve Manifold Assemblies Series S10

G1/8

fully assembled

Actuation systems:

- Pneumatic
- Electrical pilot actuated

Valve Manifold assembly, fully assembled – threaded version, Type: S10-1/8-...

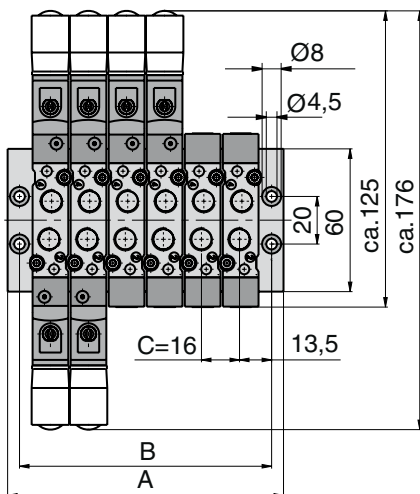
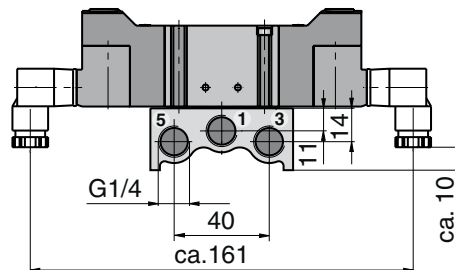
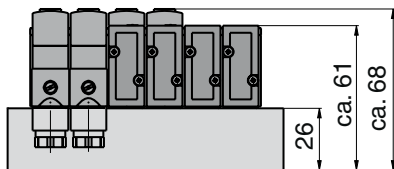

Drawing shows:
6-fold valve manifold S10-1/8-06, 24VDC
Order No. PA10385-06-0233-00
Valve positions: JJMM33

Dimension Table (mm)

Dimension	Number of valves							
	2	4	6	8	10	12	14	16
A	52	84	116	148	180	212	244	276
B	42	74	106	138	170	202	234	266

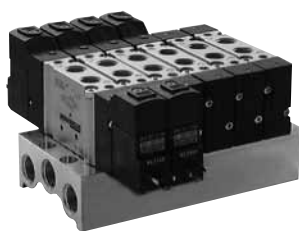

For single valves see page 18-28, for order instructions see page 36

Dimensions in mm

Valve Manifold assembly, fully assembled – version with Push-In Connections, Type: S10-Q6-..

Valve Manifold Assembly Series S10

Push-In Connections
OD 6 mm

fully assembled

Actuation systems:
– Pneumatic
– Electrical pilot actuated

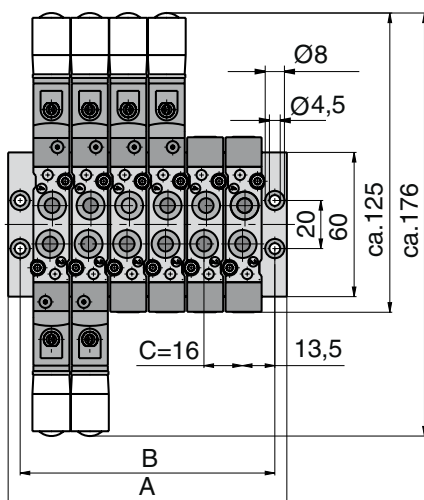
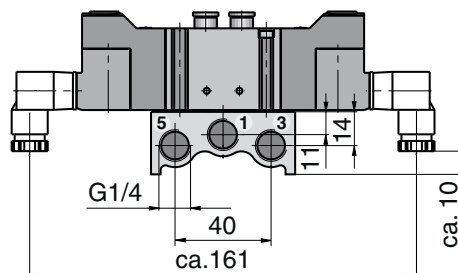
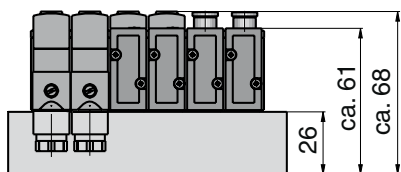

Drawing shows:
6-fold valve manifold S10-Q6-06, 24VDC
Order No. PA10386-06-0233-00
Valve positions: JJMM33

Dimension Table (mm)

Dimension	Number of valves							
	2	4	6	8	10	12	14	16
A	52	84	116	148	180	212	244	276
B	42	74	106	138	170	202	234	266

For single valves see page 18-28, for order instructions see page 36

Dimensions in mm

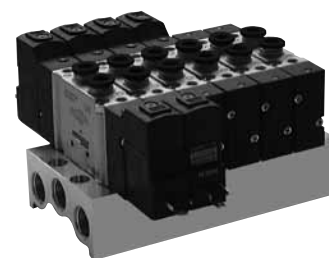

Order Instructions – Valve Manifold Assemblies

Order No.										
P	A									
				Number of valves	Solenoid version voltage					Connector
				-	-	3 3 -				

Version	
PA 10385	Valves with threaded ports G1/8 Series: S10-1/8
PA 10386	Valves with push-in ports OD 6 Series: S10-Q6

Number of Valves	
02	1 – 2 valves
04	3 – 4 valves
06	5 – 6 valves
08	7 – 8 valves
10	9 – 10 valves
12	11 – 12 valves
14	13 – 14 valves
16	15 – 16 valves

Solenoid version/voltage – for connector	
00	without solenoid
01	12 V DC
02	24 V DC
04	48 V DC
07	110 V DC
50	12 V AC
51	24 V AC
55	48 V AC
57	110 V AC
61	230 V AC
– with cable (length 1m)	
41	12 V DC
42	24 V DC
71	12 V AC
72	24 V AC
Other solenoid versions (voltages) available on request	

Connector Version	
00	without connector (standard version)
88	standard connector 15 mm wide
89	230 V AC with LED and protective circuit
92	24 V DC with LED and protective circuit

Valve positions																	
Valve positions 1-16																Flow divider at valve position	
1	2	3	4	5	6	7	8	9	10	11	12	13	14	15	16		
																	Flow divider (for dual pressure operating) none (standard) .. at valve position
02	04	06	08	10	12	14	16									↑	

Only even numbers of valves are possible!
Please enter the codes for the valve types required.

Order Codes for Valves and Cover Plates		
Code	Description	Page
A	Cover plate for unused valve position	41
P	Intermediate air supply adapter G1/8	41
Pneumatically actuated		
8	2x3/2 Way Valve NC, air spring return	18, 22
9	2x3/2 Way Valve NO, air spring return	18, 22
0	2x3/2 Way Valve NC, NO, air spring return	18, 22
1	5/2 Way Valve, spring return	22, 23, 26, 27
2	5/2 Way Valve, air spring return	22, 23, 26, 27
3	5/2 Way Valve, impulse	22, 23, 26, 27
4	5/2 Way Valve, impulse, with biased position	22, 23, 26, 27
5	5/3 Way Valve, middle position closed, spring return to middle position	22, 23, 26, 27
7	5/3 Way Valve, middle position exhausted, spring return to middle position	22, 23, 26, 27
6	5/3 Way Valve, middle position pressurized, spring return to middle position	22, 23, 26, 27

Order Codes for Valves and Cover Plates		
Code	Description	Page
Electrically actuated		
K	2x3/2 Way Valve NC, air spring return	19, 21
N	2x3/2 Way Valve NO, air spring return	19, 21
H	2x3/2 Way Valve NC, NO, air spring return	19, 21
M	5/2 Way Valve, spring return	24, 27
L	5/2 Way Valve, air spring return	24, 27
J	5/2 Way Valve, impulse	24, 27
D	5/2 Way Valve, impulse, with biased position	24, 27
G	5/3 Way Valve, middle position closed, spring return to middle position	25, 28
E	5/3 Way Valve, middle position exhausted, spring return to middle position	25, 28
B	5/3 Way Valve, middle position pressurized, spring return to middle position	25, 28

Order Codes for Valves and Cover Plates		
Code	Description	Page
Electrically actuated, with external pilot air		
X	2x3/2 Way Valve NC, air spring return	19, 21
Y	2x3/2 Way Valve NO, air spring return	19, 21
Z	2x3/2 Way Valve NC, NO, air spring return	19, 21
F	5/2 Way Valve, spring return	24, 27
R	5/2 Way Valve, air spring return	24, 27
S	5/2 Way Valve, impulse	24, 27
T	5/2 Way Valve, impulse, with biased position	24, 27
U	5/3 Way Valve, middle position closed, spring return to middle position	25, 28
W	5/3 Way Valve, middle position exhausted, spring return to middle position	25, 28
V	5/3 Way Valve, middle position pressurized, spring return to middle position	25, 28

Valve Islands, fully assembled – threaded version, Type: IM10-1/8-..

Valve Islands Series IM10

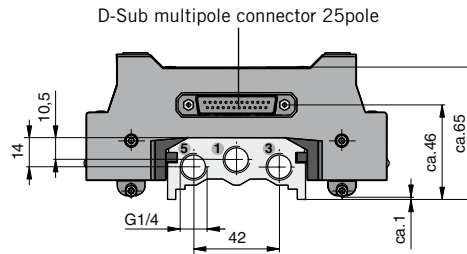
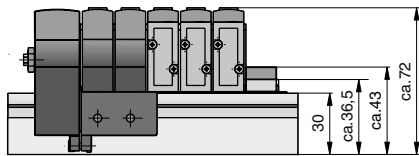

G1/8

fully assembled

Actuation systems:
– Electrical pilot actuated

Version:
Multipole version with
D-Sub multipole connector
25pole.

Valve positions:
– Combination mono/
bistable
outputs
max. 22
max. 18 (monostable)

On request:
Expandable with external
field bus components
(Profi Bus DP, Inter Bus S,
CAN Device net, AS-Interface)

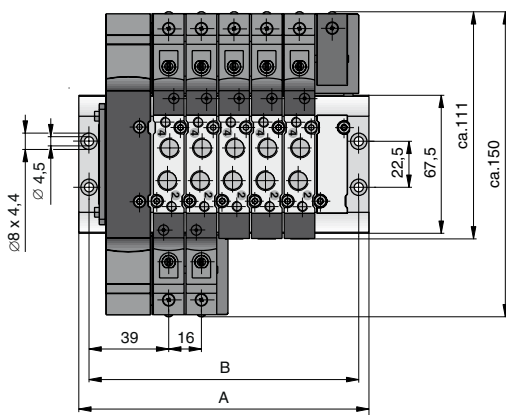

Drawing shows:
6fold valve manifold IM10-1/8-06, 24VDC
Order No. PA10490-06-22
Valve positions: JJMMMC

Dimension Table (mm)

Dimen- sion	Number of valves																	
	2	3	4	5	6	7	8	9	10	11	12	13	14	15	16	17	18	
A	78	94	110	126	142	158	174	190	206	222	238	254	270	286	302	318	334	
B	68	84	100	116	132	148	164	180	196	212	228	244	260	276	292	308	324	

For single valves see page 18-28, for order instructions see page 39

Dimensions in mm



Valve Islands Series IM10

Push-In Connections
OD 6 mm

fully assembled

Actuation systems:
– Electrical pilot actuated

Version:

Multipole version with
D-Sub multipole connector
25pole.

Valve positions:

- Combination mono-/bistabil
- Outputs
max. 22
max. 18 (monostable)

On request:

Expandable with external
field bus components
(Profi Bus DP, Inter Bus S,
CAN Device net, AS-Interface)

Valve Islands, fully assembled – with Push-In Connections, Type: IM10-Q6-..

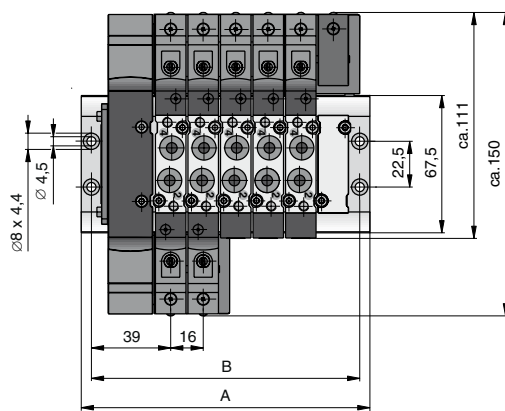
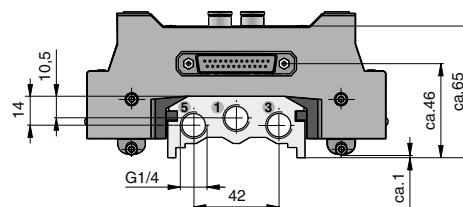
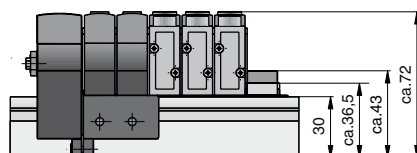

Drawing shows:
6fold Valve Islands IM10-Q6-06, 24VDC
Order No. PA10491-06-22
Valve positions: JJMMMC

Dimension Table (mm)

Dimen- sion	Number of valves																	
	2	3	4	5	6	7	8	9	10	11	12	13	14	15	16	17	18	
A	78	94	110	126	142	158	174	190	206	222	238	254	270	286	302	318	334	
B	68	84	100	116	132	148	164	180	196	212	228	244	260	276	292	308	324	

ARA®

PNEUMATIK

53-012 Wrocław tel. 71 364 72 82
ul. Wysięgowa 38 fax 71 364 72 83

www.arapneumatik.pl



For single valves see page 18-28, for order instructions see page 36

Dimensions in mm

Order Instructions – Valve Islands

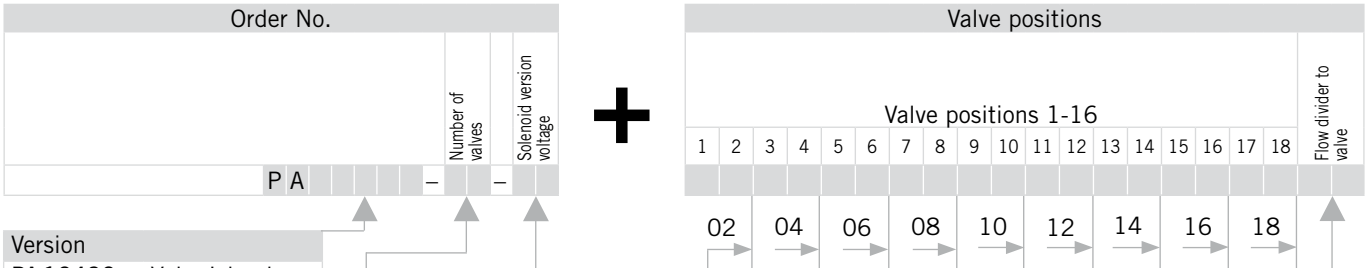

Version	
PA 10490	Valve Islands with threaded ports G1/8 Series: IM10-1/8
PA 10491	Valve Islands with push-in connections OD 6, Series: IM10-Q6

Valves	
02	2 valves
03	3 valves *
04	4 valves
05	5 valves
▼	
18	18 Valves
* uneven number of valve positions on request	

Solenoid version/voltage	
21	12 V DC
22	24 V DC

Even and uneven numbers of valves are possible!
Please enter the codes for the valve types required.

Flow divider (for dual pressure operating) without (standard) .. at valve position

Order Codes for Valves and Cover Plates		
Code	Description	Page
A	Cover plate for unused valve position	41
C	Cover plate (monostable)*	41
O	Cover plate (bistabil)*	41
P	Intermediate air supply adapter G1/8	41

* including electrical socket

Order Codes for Valves and Cover Plates		
Code	Description	Page
Electrically actuated		
K	2x 3/2 Way Valve NC, air spring return	19
N	2x 3/2 Way Valve NO, air spring return	19
H	2x 3/2 Way Valve NC, NO, air spring return	19
M	5/2 Way Valve, spring return	24
L	5/2 Way Valve, air spring return	24
J	5/2 Way Valve, impulse	24
D	5/2 Way Valve, impulse, with biased position	25
G	5/3 Way Valve, middle position closed, spring return to middle position	25
E	5/3 Way Valve, middle position exhausted, spring return to middle position	25
B	5/3 Way Valve, middle position pressurized, spring return to middle position	25

Order Codes for Valves and Cover Plates		
Code	Description	Page
Electrically actuated, with external pilot air		
X	2x 3/2 Way Valve NC, air spring return	19
Y	2x 3/2 Way Valve NO, air spring return	19
Z	2x 3/2 Way Valve NC, NO, air spring return	19
F	5/2 Way Valve, spring return	24
R	5/2 Way Valve, air spring return	24
S	5/2 Way Valve, impulse	24
T	5/2 Way Valve, impulse, with biased position	25
U	5/3 Way Valve, middle position closed, spring return to middle position	25
W	5/3 Way Valve, middle position exhausted, spring return to middle position	25
V	5/3 Way Valve, middle position pressurized, spring return to middle position	25

RPS-Manifolds

for Directional Valves
 – Series S10-1/8
 – Series S10-Q6

RPS manifolds reduce and simplify the tubing layout. They provide a space-saving, clear and simple, compact solution. RPS manifolds have a common compressed air supply port (P) and common exhaust ports (R, S). From 2 to 16 valves can be mounted on them. (Other sizes available on request)

- Materials:**
 RPS manifold
 – aluminium
 Screws
 – galvanized steel
 Gasket
 – oil-resistant rubber

Dimension Table (mm) – Type: RPSL-S10-1/8-..

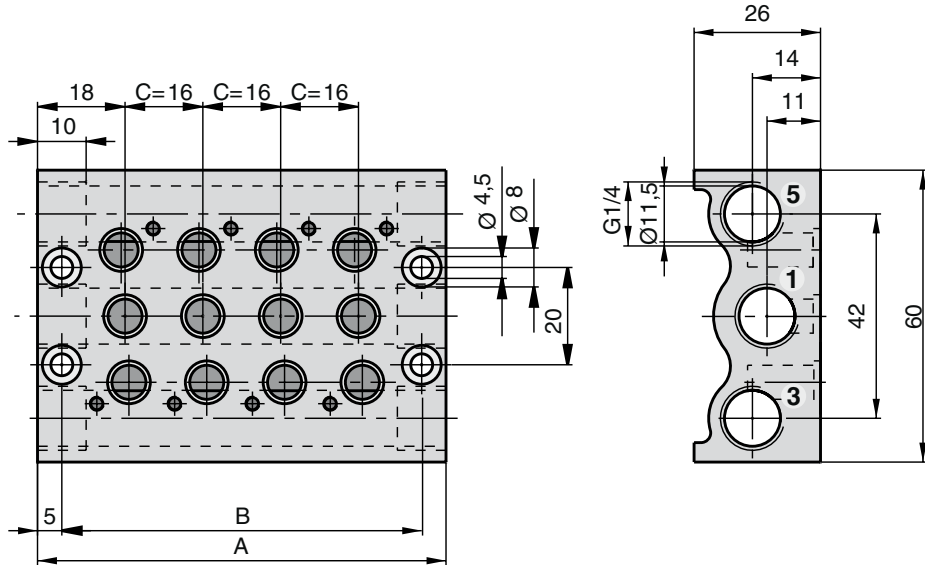

Drawing shows: 4fold valve manifold

Dimension Table (mm)

Type	Number of valves	Dimension	
		A	B
RPSL-S10-1/8-02	02	52	42
RPSL-S10-1/8-04	04	84	74
RPSL-S10-1/8-06	06	116	106
RPSL-S10-1/8-08	08	148	138
RPSL-S10-1/8-10	10	180	170
RPSL-S10-1/8-12	12	212	202
RPSL-S10-1/8-14	14	244	234
RPSL-S10-1/8-16	16	276	266

Order Instructions and Weight

Order Instructions *		consisting of			Weight (mass) [kg]
Type	Order No.	Manifold	Screws	Seals	
RPSL-S10-1/8-02	PD47254-0002	1	4	2	0.116
RPSL-S10-1/8-04	PD47254-0004	1	8	4	0.190
RPSL-S10-1/8-06	PD47254-0006	1	12	6	0.264
RPSL-S10-1/8-08	PD47254-0008	1	16	8	0.337
RPSL-S10-1/8-10	PD47254-0010	1	20	10	0.410
RPSL-S10-1/8-12	PD47254-0012	1	24	12	0.484
RPSL-S10-1/8-14	PD47254-0014	1	28	14	0.557
RPSL-S10-1/8-16	PD47254-0016	1	32	16	0.630

*other versions on request



For single valves see page 18-28, for order instructions see page 36

Dimensions in mm

Dimension Table (mm) – Type: RPSL-S10-1/4-..

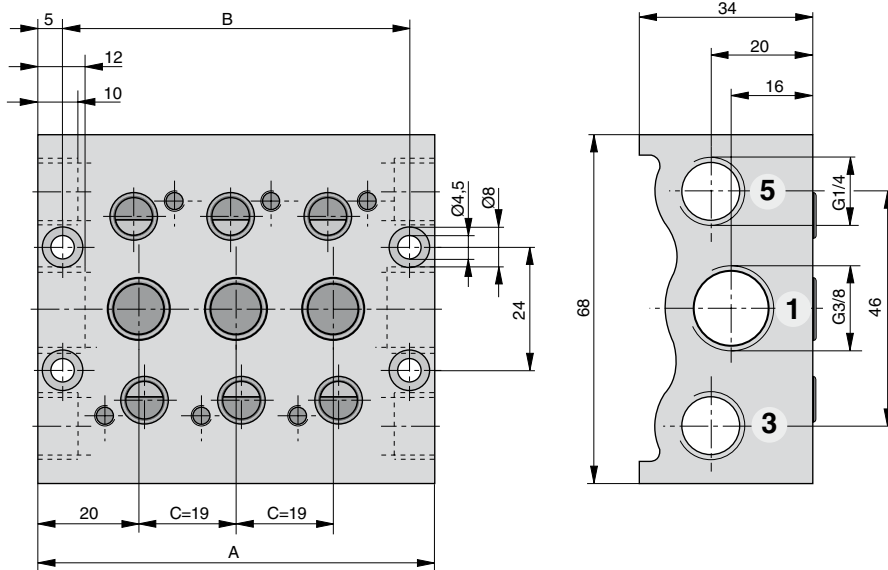

Drawing shows: 3fold manifold

Maßtabelle (mm)

Type	Number of valves	Dimension	
		A	B
RPSL-S10-1/4-02	02	59	49
RPSL-S10-1/4-04	04	97	87
RPSL-S10-1/4-06	06	135	125
RPSL-S10-1/4-08	08	173	163
RPSL-S10-1/4-10	10	211	201
RPSL-S10-1/4-12	12	249	239
RPSL-S10-1/4-14	14	287	277
RPSL-S10-1/4-16	16	325	315

Order Instructions and Weight

Order Instructions *	Order No.	consisting of			Weight (mass) [kg]
		Manifold	Screws	Seals	
RPSL-S10-1/4-02	PD49210-0002	1	4	2	0.255
RPSL-S10-1/4-04	PD49210-0004	1	8	4	0.424
RPSL-S10-1/4-06	PD49210-0006	1	12	6	0.594
RPSL-S10-1/4-08	PD49210-0008	1	16	8	0.736
RPSL-S10-1/4-10	PD49210-0010	1	20	10	0.932
RPSL-S10-1/4-12	PD49210-0012	1	24	12	1.101
RPSL-S10-1/4-14	PD49210-0014	1	28	14	1.270
RPSL-S10-1/4-16	PD49210-0016	1	32	16	1.439

*other versions on request

For single valves see page 18-28

Dimensions in mm

RPS Manifolds

for Directional Valves
 – Series S10-1/4
 – Series S10-Q8

RPS manifolds reduce and simplify the tubing layout. They provide a space-saving, clear and simple, compact solution. RPS manifolds have a common compressed air supply port (P) and common exhaust ports (R, S). From 2 to 16 valves can be mounted on them. (Other sizes available on request)

Materials:

- RPS manifold
- aluminium
- Screws
- galvanized steel
- Gasket
- oil-resistant rubber



Accessories

for Valve Manifold Assemblies

Flow Divider

Material: Aluminium

Order No.

- S10-1/8 (Q6): **PD47353**
- S10-1/4 (Q8): **PD49322**

Cover Plate for unused Valve Positions

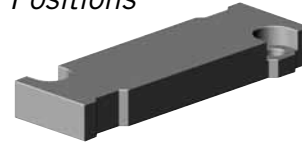

Material: Aluminium

Order No.

- S10-1/8 (Q6): **KL9114**
- S10-1/4 (Q8): **KL9186**

Intermediate Air Supply Adapter

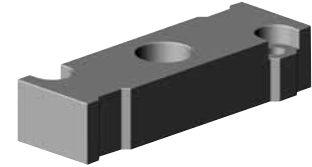

Material: Aluminium

Order No.

- S10-1/8 (Q6): **KL9115**
- S10-1/4 (Q8): **KL9187**

Clamp Mounting for DIN Rail 35 mm



Versions:

- for Valve Manifolds S10
- for Valve Islands IM10

Material: Aluminium

The delivery includes:

- 1 clamp mounting
- 4 screws

Order Instructions – Clamp Mounting for S10-1/8 (Q6)

Clamp Mounting Number of valves	Order No.	
	for valve manifolds Type: S10-1/8	for valve islands Type: IM10-1/8
2	PD47393-0002	PD47949-0002
4	PD47393-0004	PD47949-0004
6	PD47393-0006	PD47949-0006
8	PD47393-0008	PD47949-0008
10	PD47393-0010	PD47949-0010
11 – 18	on request	PD48270

Order Instructions – Clamp Mounting for S10-1/4 (Q8)

Clamp Mounting valves	Order No.
	for RPS-manifold Type: RPSL-S10-1/4-..
2	PD49423-0002
4	PD49423-0004
6	PD49423-0006
8	PD49423-0008
10	PD49423-0010
12-16	on request

Cable with D-Sub multipole connector 25pole



Order Instructions – Cable

Cable length	Electrical protection	Order No.
2 m	IP40	KL3355
5 m	IP40	KL3356
5 m	IP65	KL3357

Dimensions in mm

Dimension Table – Mounting Bracket for Single Valves

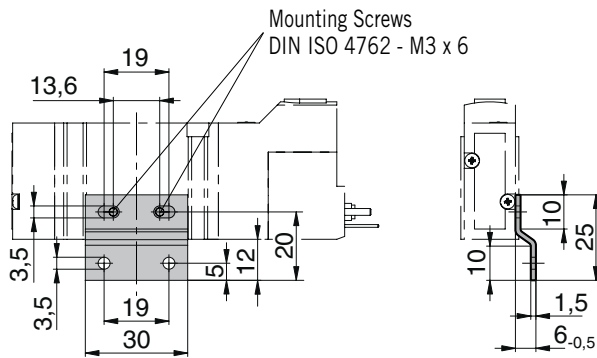

Mounting Bracket for Single Valves Series S10

Accessories
for Single Valves



Material: Steel, passivated

Order No.: KL9112

Dimension Table – Adapter Plate for Single Valves S10-1/8 (Q6)

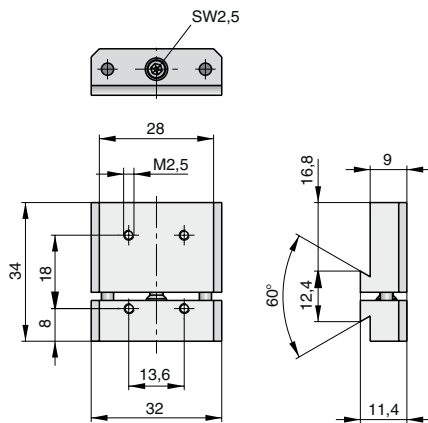

Adapter Plate for Single Valves Series S10-1/8 (Q6) Series S10-1/4 (Q8)

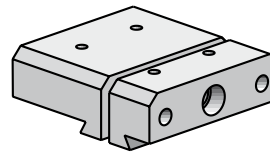

Adapter plate for direct mounting on Parker Origa profile cylinders

Dimension Table – Adapter Plate for Single Valves S10-1/4 (Q8)

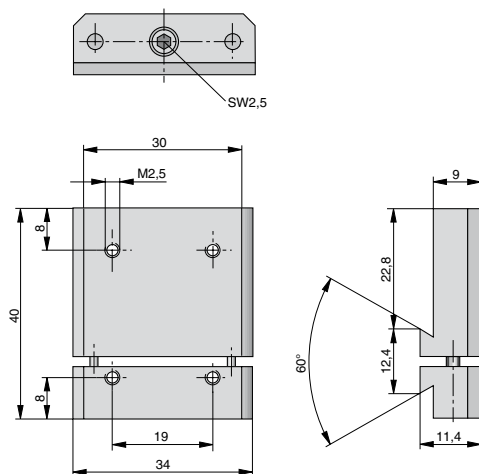

Material: Aluminium

Order No.
– S10-1/8 (Q6): **PD47420**
– S10-1/4 (Q8): **PD49325**

Dimensions in mm

Accessories

for Single Valves

Connectors for Series S10



- Standard version
- version with LED

Material: Plastic

Dimension Table – Connector

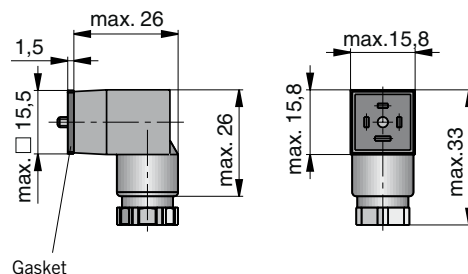

Versions and Order Instructions

Version	Voltage	Colour	Order No.
Standard version	230 V AC/DC	black	KL9052
Bipolar LED and VDR to protect supply and switch	230 V AC	transparent	KL9056
	24 V DC	transparent	KL9118

ARA[®]

PNEUMATIK

53-012 Wrocław tel. 71 364 72 82
ul. Wyścigowa 38 fax 71 364 72 83

www.arapneumatik.pl



Dimensions in mm