



AIR TORQUE

**INSTALLATION, MAINTENANCE AND
OPERATING INSTRUCTION MANUAL FOR
AIR TORQUE ACTUATORS AT-HD SERIES**

AIR TORQUE S.p.a.
24060 Costa di Mezzate
Via dei Livelli di Sopra N° 8/11
Bergamo Italy
Tel. +39 035 682299
Fax +39 035 687791
www.airtorque.it

Doc. n°:
IMAT AT-HD- EN
Issue: 12/16
Page: 1/20

INSTALLATION, MAINTENANCE AND OPERATING INSTRUCTION MANUAL FOR AT-HD series ACTUATORS

CONTENTS:

- 1) GENERAL**
- 2) WARNING**
- 3) WORKING CONDITIONS AND TECHNICAL DATA**
- 4) OPERATING FUNCTION AND DIRECTION OF ROTATION**
- 5) INSTALLATION INSTRUCTIONS**
- 6) MAINTENANCE INSTRUCTIONS**
- 7) DISASSEMBLING INSTRUCTIONS**
- 8) ASSEMBLING INSTRUCTIONS**
- 9) ADJUSTMENT INSTRUCTIONS**
- 10) PERIODIC CHECKS**
- 11) LIFTING AND HANDLING**
- 12) ACTUATOR INSPECTIONS (TO BE CARRIED OUT ON ACTUATOR RECEIPT)**
- 13) STORAGE INSTRUCTIONS**
- 14) ACTUATOR ASSEMBLY AND PARTS LIST**

1. GENERAL

Important information about the installation, functioning, maintenance and storage for AIR TORQUE scotch-yoke actuators AT-HD series are included in this manual.

Please read these instructions carefully and keep them for future reference. It's important that the maintenance and the usage of AIR TORQUE products is carried out only by trained and qualified personnel.

Into the consideration of the all possible variations on the configuration of the product due to the different services and working conditions, some specific indications may not be mentioned in this manual, in case of doubt contact Air Torque for any additional information needed.



2. WARNING

- Do not operate the actuator with oxidizing, corrosive or unstable gases or liquids (only Group 2 fluids according to 97/23/EC).
- The AT-HD series actuator power cylinder can be operated with fluids of the Group 1 according to PED 97/23/EC only if the power cylinder is specifically produced to be operated with this fluid and the actuator data-plate clearly states the compatibility with them, provided that the fluids of Group 1 are compatible with internal parts.
- For actuators installed in areas of potentially explosive atmosphere (ATEX), make sure that during operations the internal parts of the actuator do not come in contact with the atmosphere itself.
- In case the actuator cylinder is pressurized with not inert gas or media, avoid any contact of the pressure media during decompressing with surrounding atmosphere.

**AIR TORQUE****INSTALLATION, MAINTENANCE AND
OPERATING INSTRUCTION MANUAL FOR
AIR TORQUE ACTUATORS AT-HD SERIES****AIR TORQUE S.p.a.**
24060 Costa di Mezzate
Via dei Livelli di Sopra N° 8/11
Bergamo Italy
Tel. +39 035 682299
Fax +39 035 687791
www.airtorque.it**Doc. n°:**
IMAT AT-HD- EN
Issue: 12/16
Page: 2/20


- Referring to Machine Directive 2006/42/CE, actuators are classified as “partly machinery” (see declaration of incorporation). Therefore, the actuator can not to be put into service until the machinery and/or the final system, where the actuator is incorporated, will be declared in compliance with the requirements of the Directive.
- AIR TORQUE actuators AT-HD series are designed, produced and classified according to the Atex Directive 94/9/EC (see actuator’s marking and safety instructions). Before using the actuators in potentially explosive atmosphere areas, check the actuator compliance with the ATEX classification required. See the actuator marking and the ATEX safety instructions.
- The electrical connections of the accessories that may be required to operate the actuator, are under the responsibility of the user; check these components compliance with the Zone classification where they shall be installed.
- The use, the installation and the maintenance of AIR TORQUE actuators AT-HD series must be carried out by adequately trained personnel. For the usage, installation and maintenance of AIR TORQUE actuators AT-HD series it is recommended to comply with the safety notice and to use proper protective equipment to prevent incidents and operate in healthy conditions.
- It is important that the actuator is used only within the working limits marked on the actuator data plate and specified in the technical specifications.
- Do not operate the actuator over the temperature limits: internal and external components could be damaged.
- Do not operate the actuator over the pressure limits: internal and external components could be damaged.
- Do not use the actuator in corrosive environments with inadequate protection: internal and external parts could be damaged.
- Do not disassemble the Spring Module and do not try to modify or rework the spring housing, this may result in serious injury (see the label over the Spring Module). In case of spring maintenance needed, send the actuator Spring Module back to AIR TORQUE.
- Before performing any operation on the actuator, shut off the electric/pneumatic/hydraulic supply of the actuator and exhaust the pressure from the actuator cylinder.
- Before installing the actuator onto the valve make sure that the rotation direction and the position indicator (if available) are in the correct position.
- If the actuator is incorporated in a system or used within safety devices or circuits, the customer shall ensure that the national and local safety laws and regulations are respected.

3. WORKING CONDITIONS AND TECHNICAL DATA

- **Power Operating media:**

Dry or lubricated air, inert gas, inert fluid, hydraulic oil. In case of pressure medium different than Group 2 fluids according to 97/23/EC, contact Air Torque.

The operating media must have a dew point equal to -20°C (-4°F) or at least 10°C below the ambient temperature. The maximum particle size contained into the operating media must not exceed $30\ \mu\text{m}$.

 AIR TORQUE [®]	INSTALLATION, MAINTENANCE AND OPERATING INSTRUCTION MANUAL FOR AIR TORQUE ACTUATORS AT-HD SERIES	AIR TORQUE S.p.a. 24060 Costa di Mezzate Via dei Livelli di Sopra N° 8/11 Bergamo Italy Tel. +39 035 682299 Fax +39 035 687791 www.airtorque.it	Doc. n°: IMAT AT-HD- EN Issue: 12/16 Page: 3/20
--	---	--	--

Make sure that the operating media is compatible with the actuator internal parts and with the lubricant.

- **Supply Pressure (see the actuator marking):**

- for actuators supplied with low pressure media: up to **10 bar (145 Psi)** depending on actuator model (Scotch Yoke size compared to the Power Module size).
- for actuators supplied with high pressure media is:
 - for actuators supplied with gas, up to **103 bar (1500 Psi)** depending on actuator model (Scotch Yoke size compared to the Power Module size).
 - for actuators supplied with oil or inert liquid, up to **207 bar (3000 Psi)** depending on actuator model (Scotch Yoke size compared to the Power Module size).

- **Operating temperature (see the actuator marking):**

==> Standard actuators “S” from -40°C (-40°F) to +80°C (+176°F)

==> High temperature actuators “H” from -15°C (+5°F) to +150°C (+300°F)

==> Extremely low temperature actuators “R” from -60°C (-76°F) to +80°C (+176°F)

Caution: for low and high temperature service, special components and greases are required. Please contact AIR TORQUE. Working at high or low temperature can affect the life and the output torque of the actuator.

- **Operating time (see the technical data sheet).**

Caution: the operating time depends on several factors such as supply pressure, supply system capacity (pipe diameter, flow capacity of pneumatic accessories), valve type, valve torque and figures, applied safety factor, cycle frequency, temperature, etc.

Rotation and stroke adjustment (see the technical data sheet):


For standard actuators AT-HD series (90° rotation), +/-5°stroke adjustment at 0° and 90°.

- **Lubrication:**

The actuators are factory lubricated for the life of the actuator in normal working conditions. The standard lubricant type GSHD is suitable for use from -40°C (-40°F) to +80°C (+176°F). For extreme low temperature (L) and high temperature (H) services, special grease is required: please contact AIR TORQUE.

- **Construction:**

Standard configuration AT-HD are designed as: Central Module with Central Stroke Adj and Power Module without tie rods. The scotch yoke actuator design suitable for both indoor or outdoor installation.

 AIR TORQUE [®]	INSTALLATION, MAINTENANCE AND OPERATING INSTRUCTION MANUAL FOR AIR TORQUE ACTUATORS AT-HD SERIES	AIR TORQUE S.p.a. 24060 Costa di Mezzate Via dei Livelli di Sopra N° 8/11 Bergamo Italy Tel. +39 035 682299 Fax +39 035 687791 www.airtorque.it	Doc. n°: IMAT AT-HD- EN Issue: 12/16 Page: 4/20
--	---	--	--

- **Protection and corrosion resistance:**

All the actuators are supplied with a corrosion protection coating as per the data sheet. Other types of coatings are available on customer's request. Before installing the actuator in aggressive environment, ensure that the selected protection level is suitable.

- **Actuator designation and marking (see the actuator marking and the technical data sheets):**

The actuator type, size, operating pressure, output torque, rotation direction, spring action, operating temperature and type of connections/interfaces are generally established by designation during ordering phases.

All the AIR TORQUE AT-HD series actuators are marked showing the serial number and all necessary information about usage, service and operation.

4. OPERATING FUNCTION AND DIRECTION OF ROTATION

The AIR TORQUE AT-HD actuators series are pneumatic/hydraulic devices for remote operation of industrial valves. The operation (90° rotation) may be activated by different control system. The actuator control system can be housed within cabinet and/or on a panel assembled on the actuator or in a remote location. The standard rotating direction for the AIR TORQUE AT-HD actuators series is clockwise to close. For spring return actuator in case of pressure failure, the following functions are possible: fail open or fail close. Please see the technical data sheets.

5. INSTALLATION INSTRUCTIONS

The actuator operation allows the opening and the closing of different type of valves. All the necessary technical information to install correctly the actuator onto a valve (i.e.: dimensions, output torque, supply pressure and volume, stroke adjustment, operating time, operating temperature, rotation direction and weight) are clearly marked on the actuator data plate and/or in the catalogue and in the technical data sheets. Please read all technical information before proceeding with the actuator installation.



Important safety notice!

- For safety reasons, the actuator must not be pressurized during the installation as serious injury may result.
- Make sure that the pipes, fittings and seals connected to the actuator are cleaned to prevent external substances entering into the actuator's chambers.
- Make sure that the operating pressure media composition used for the actuator operation meets the operating conditions given in this manual and corresponds to what the actuator was manufactured for.
- Before fitting the actuator onto the valve, make sure that the actuator and the valve are correctly oriented, with reference to the rotation direction required.

- Remove the plugs from the actuator power connections during installation and operation, protect and close the power connections which may not being used immediately.
- At any time must be avoided that dangerous, corrosive substances and all unnecessary fluids enter into the actuator pressure chambers by using adequate filters.
- When fitting accessories onto the actuators, assemble them in such a way that the emergency controls may be easily accessible for emergency manual operation.
- It is the user responsibility to ensure that Actuator and control components, must be protected from electrical spikes, surge and lightning strikes as well as all magnetic fields.

Installation on valves

Before installing the actuator onto the valve, verify that the actuator maximum transmissible torque does not exceed the torque limit according to ISO 5211, in relation to the available ISO flange and the drive shaft connection, considering: the maximum actuator output torque, the maximum supply pressure and the maximum valve torque.

Before proceeding with the assembly of the actuator onto the valve, make sure that the actuator, when pressurized, operates in the desired rotation direction and that both actuator and valve are in the correct position.



Important: when using AT-HD series spring return actuators make sure that the rotation direction is correct for your application when power supply or electricity failure occurs.

Mount the actuator onto the valve.

The actuator can be assembled onto a valve flange in two ways: by the actuator housing threaded holes, or by interposition of a bracket/flange. The actuator drive shaft is generally connected to the valve stem with an insert bushing or with a stem extension (coupling).

The valve and the actuator or bracket flange shall be cleaned in order to remove everything that might prevent a perfect adherence between the interfaces (especially all traces of grease), since the torque is transmitted by friction.

In any cases make sure that all connecting plans are completely adhere to one another and avoid areas of non-contact. For bolts/nuts tightening torque see Table 1.

Table 1 - Recommended tightening torque (for screws, nuts etc.) with $Rp_{0.2} > 450 \text{ N/mm}^2$													
M	M5	M6	M8	M10	M12	M14	M16	M20	M22	M24	M30	M33	M36
Nm	5	9	22	40	65	100	170	330	460	580	1100	1450	1800

6. MAINTENANCE INSTRUCTIONS

With the information given below, AIR TORQUE provides the end user with all the necessary information for maintenance.



Important: before performing any operation on the actuator, shut off the electric/pneumatic/hydraulic supply of the actuator and exhaust the pressure from the actuator cylinder.

Disconnect all electric/pneumatic/hydraulic connections, remove all the accessories and remove the actuator from the valve.

Under normal working conditions, the actuator requires only periodical check to ensure proper operation.

- Maintenance (disassembly, maintenance and rebuilding) of AIR TORQUE AT-HD series actuators is allowed only to AIR TORQUE personnel or to properly trained personnel. In case of these conditions will be not respected, the product warranty will expire!
- Spare parts for maintenance are available (Table 2) the maintenance is required in relation to: environmental conditions, operating conditions and actuator size.
- After each operation performed on the actuator (including the maintenance), before operating the actuator, make sure that the operating conditions are restored and that the actuator is properly placed back in service.
- Remove all piping and accessories if mounted that will interfere with the module(s) that are to be worked on.
- In case of disassembly, maintenance and rebuilding it is recommended to perform the required operations in a clean area and on a workbench.

7. DISASSEMBLING INSTRUCTIONS



Warning: appropriate lifting equipment may be used.

There are two possible configurations about the stroke adjustment.

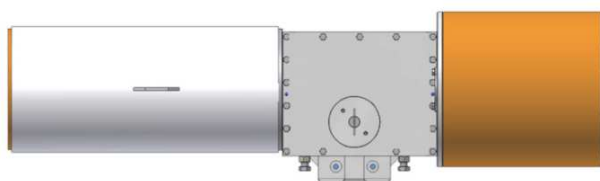


Figure 1 - OPTION "A" Central Stroke Adj. - STD

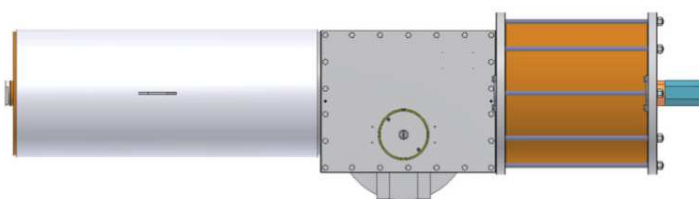


Figure 2 OPTION "B" External Stroke Adj. + Tie Roads

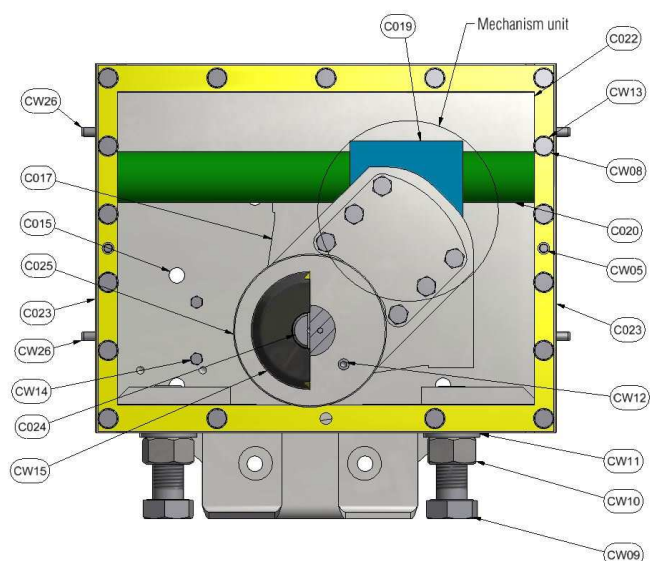


Figure 3- PART NUMBER - Central stroke Adj - STD

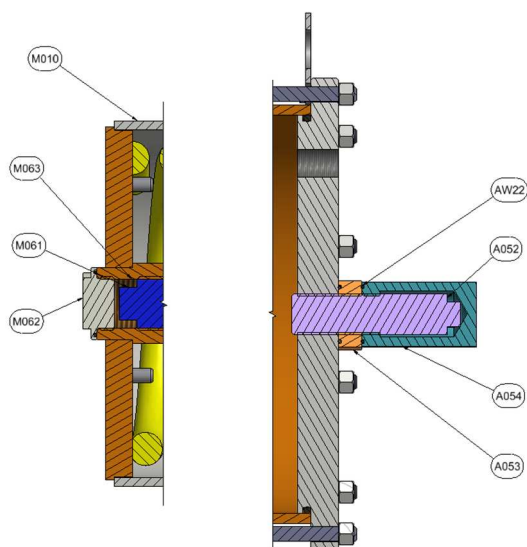


Figure 4- PART NUMBER - External stroke Adj.

7.1. Power Module disassembly:

7.1.1. Pneumatic module:

7.1.1.1. Before removing the power module, make sure that the actuator is in end of stroke position (**only for Spring Return actuators**);

for actuator with central stroke adj Figure 3, unscrew the both nuts (CW10) and completely unscrew both the stop cap screws (CW09).

for actuator with external stroke adj. Figure 4 unscrew the cover (A054), remove the adjusting nut (A053) and completely unscrew the travel adjustment screw (A052).

7.1.1.2. For standard power module (Figure 5), progressively loosen all the screw until the end cylinder flange (A002) is relieved from all the tension. Completely unscrew all the screw (AW06).

7.1.1.3. **Only For power module with Tie Roads (Figure 6)**, progressively loosen all the nuts (AW21) of the tie rods (A055) until the flange is relieved from all the tension. Completely unscrew all the nuts (AW21)

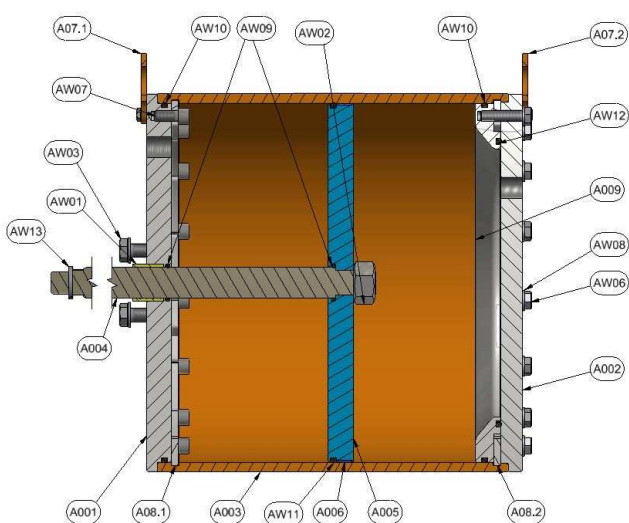


Figure 5 - Power Module - STD

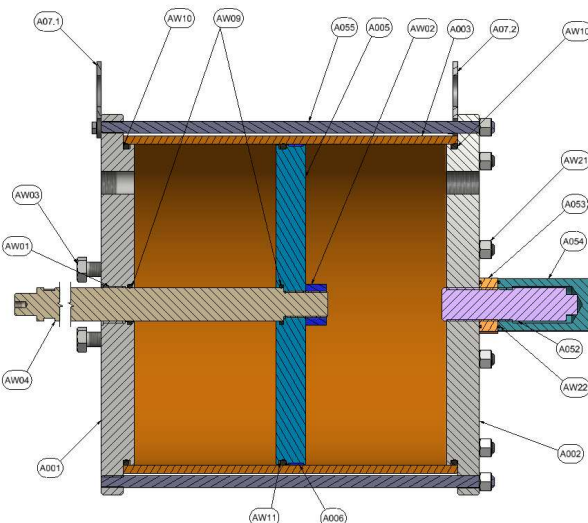


Figure 6 - Power Module - External stroke Adj. + Tie Roads



Warning: after loosening all the nuts/screw by 2/3 revolutions, make sure that the flange is not in tension. Otherwise, check that you have correctly followed the steps indicated in paragraph 7.1.1.1 and 7.1.1.2.

7.1.1.4. Remove the end cylinder flange (A002)

7.1.1.5. Remove the sector retainer (A08.2) and the retainer flange (A009)

7.1.1.6. **Only for actuators with Tie Road (Figure 6)** remove the tie rods (A055) and disengage the power cylinder (A003) from the piston (A005).

- 7.1.1.7. Remove the position indicator from the Central Module unscrewing the screws (CW12 - Figure 3)
- 7.1.1.8. Remove the cover (C025) of the Central Module unscrewing the screws (CW08); it may be necessary to lever with one or more screwdrivers.
- 7.1.1.9. Remove the cover gasket (C022)
- 7.1.1.10. By holding with a key the piston shaft (A004) inside the central module, unscrew the nut (AW02) completely then remove the piston (A005) from the piston shaft.
- 7.1.1.11. Disengage the piston shaft (A004) from the Central Module. Pay attention to not damage the pin of the piston shaft (AW01).
- 7.1.1.12. Unscrew the screws (AW07) and disengage the power cylinder (A003).
- 7.1.1.13. Unscrew the hexagonal screws (AW03) between the Central Module and the cylinder connection flange (A001).
- 7.1.1.14. Remove the cylinder connection flange (A001).
- 7.1.1.15. Remove the module gasket (A023).
- 7.1.1.16. If seals and the sliding parts are damaged, they shall be replaced during the maintenance, while a lubrication may be necessary for mechanical parts. (See Table 2)

7.1.2. Hydraulic module:

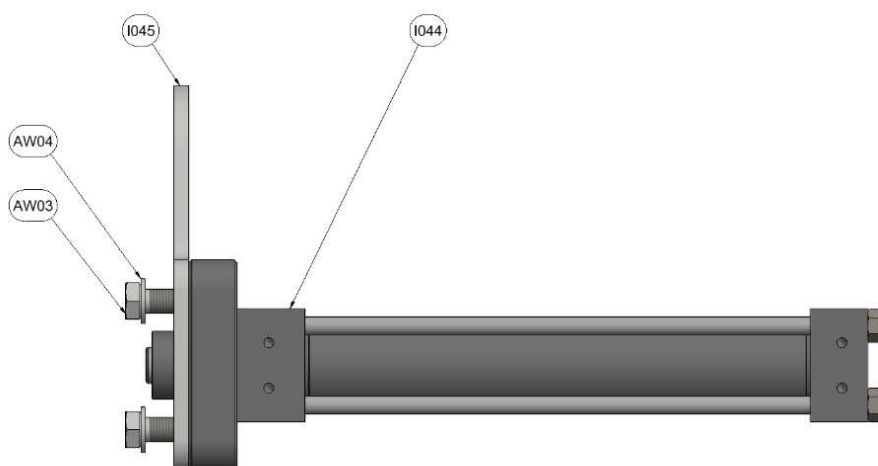


Figure 7 – Hydraulic cylinder

- 7.1.2.1. Before removing the power module, make sure that the actuator is in end of stroke position (**only for Spring Return actuators**);
- 7.1.2.2. for actuator with central stroke adj Figure 3, unscrew the both nuts (CW10) and completely unscrew both the stop cap screws (CW09).
- 7.1.2.3. Remove the position indicator from the Central Module unscrewing the screws (CW12 - Figure 3).
- 7.1.2.4. Remove the cover (C025) of the Central Module unscrewing the screws (CW08); it may be necessary to lever with one or more screwdrivers.
- 7.1.2.5. Remove the cover gasket (C022)



- 7.1.2.6. Disengaged the piston shaft from the Central Module. Pay attention to not damage the pin of the piston shaft.
- 7.1.2.7. Unscrew the hexagonal screws (AW03) between the Central Module and the hydraulic cylinder (I044)
- 7.1.2.8. Remove the hydraulic cylinder (I044) and lifting bracket (I045)
- 7.1.2.9. For hydraulic cylinder disassembly refer to specific cylinder manual. (IMAT AT-HD HYD)

7.2. Spring Module:

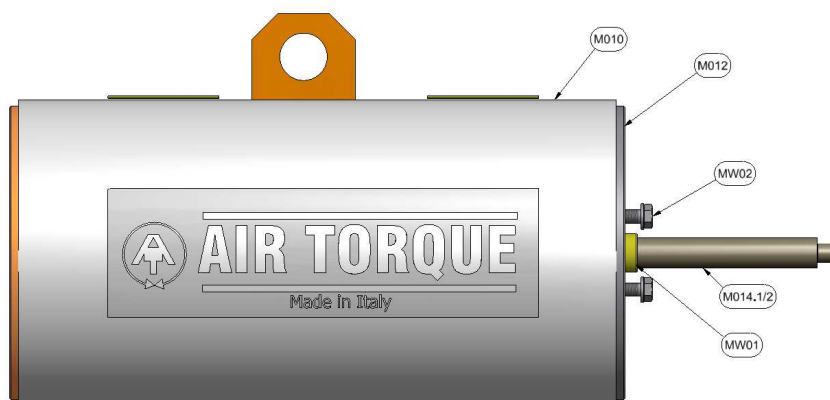


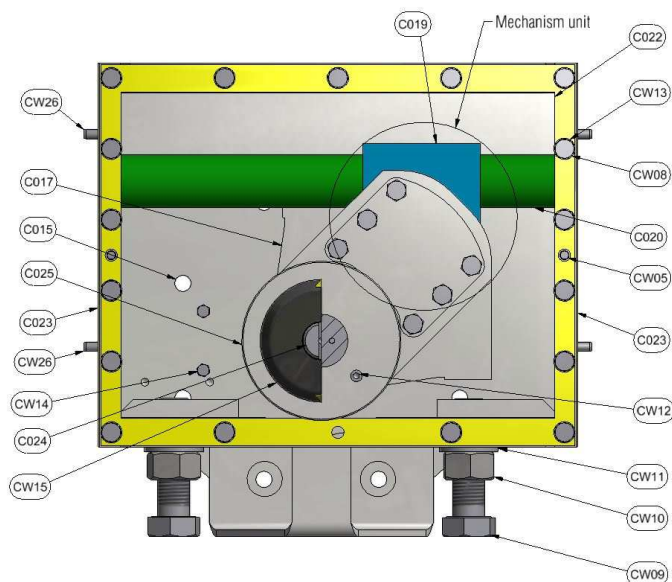
Figure 8 - Spring module STD

- 7.2.1. Before removing the Spring Module, make sure that the Power Module (if any) is not pressurized and that all connections have been removed; see warning in paragraph 7.
- 7.2.2. From the inside of the Central Module, unscrew the hexagonal screws (MW02) from the Spring Cylinder (M010).
- 7.2.3. Separate the whole Spring Module from the Central Module; do not damage the sleeve during (MW01) the disengagement of the shaft spring (M014.1/2).
- 7.2.4. Remove the gasket of the module (C022).



Warning: do not perform any kind of operation on the Spring Module. If necessary, for maintenance or other operations please contact AIR TORQUE.

7.3. Central Module disassembly



Refer. To Figure 3

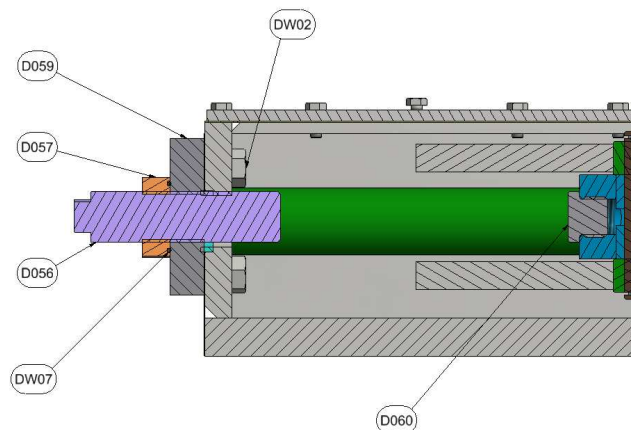


Figure 9 - Double Acting with External Stroke Adj.

Before proceeding, make sure that the Central Module is isolated from the other modules. If necessary, follow the steps as per paragraph 7.1) and 7.2).

7.3.1. Removing the adjustment screws (only for Double Acting actuators with external stroke Adjustment Figure 9)

- 7.3.1.1. Unscrew the nut (D057)
- 7.3.1.2. Completely unscrew the adjustment screw (D056)
- 7.3.1.3. Unscrew the hexagonal screws (DW02) of the connecting plate DA from the inside of the Central Module, if any
- 7.3.1.4. Remove the plate DA (D059), if any

7.3.2. Disassembling of the Central Module

- 7.3.2.1. Disengage the guide bar (C020) from the Central Module and from the Mechanism Unit
- 7.3.2.2. Remove the Mechanism Unit from the Central Module
- 7.3.2.3. Pull out and separate all the components of the Mechanism Unit

Perform the maintenance of the mechanical parts using lubricant, replace the seals and the sliding parts, if they are damaged or if it is necessary. (See Table 02)



8. ASSEMBLING INSTRUCTIONS

Before performing the assembly, make sure that:

- All the components are clean and in good condition
- The spare parts and the lubricant used are suitable for the operating temperature of the AT-HD series actuator (please see AIR TORQUE data sheets).

Note: the lubricants suitable for the different operating temperatures (Standard actuators "S", H and L), are available in AIR TORQUE.



Warning: during the assembly, pay attention to the placement of the Power and Spring Modules referred to the Central Module for a correct rotation direction of the actuator (see par. 4, Operating function and rotation direction).

8.1. Central Module (Figure 3):

- 8.1.1. Reassemble the Mechanism Unit
- 8.1.2. Screw the mechanism plug (D060) into the threaded hole of the Mechanism Unit (only for Double Acting actuators). This step must be performed also for the conversion of a Spring Return actuator into a Double acting actuator.
- 8.1.3. Carefully insert the Mechanism Unit in the proper housing of Central Module.
- 8.1.4. Insert the guide bar (C020) in the Central Module engaging it in the Mechanism Unit.


8.2. Spring Module (only for Spring Return actuators – Figure 8):

- 8.2.1. Place the module gasket (C023) in the center of the sleeve (MW01)
- 8.2.2. Insert the shaft (M14.1/2) of the spring in the Central Module; do not damage the sleeve (MW01).
- 8.2.3. Insert the cylindrical end part of the shaft (M014.1/2) in the Mechanism Unit.
- 8.2.4. Place in position the Spring Module and screw the hexagonal screws (MW02) from the inside of the Central Module, to fix the Spring Module to the Central Module.

8.3. Power Module (Figure 5):

8.3.1. Pneumatic module:

- 8.3.1.1. Place the module gasket (C023) in the center of the sleeve (AW01)
- 8.3.1.2. From the inside of the Central Module, screw the hexagonal screws (AW03), between the Central Module and the Power Module, in the head flange (A001)
- 8.3.1.3. Insert the cylinder (A003) on the cylinder connection flange (A001); place the sector retainer (A08.1) and progressively tighten all the screw in the cylinder connection flange (AW07)
- 8.3.1.4. Insert and fix the piston shaft (A004) in the mechanism unit and the piston (A005), by screwing the piston nut (AW02)
- 8.3.1.5. Insert the retainer flange (A009) (pay attention at O-Ring AW10). Place the O-Ring (AW12) and the retainer sector (A08.1)

 AIR TORQUE ®	INSTALLATION, MAINTENANCE AND OPERATING INSTRUCTION MANUAL FOR AIR TORQUE ACTUATORS AT-HD SERIES	AIR TORQUE S.p.a. 24060 Costa di Mezzate Via dei Livelli di Sopra N° 8/11 Bergamo Italy Tel. +39 035 682299 Fax +39 035 687791 www.airtorque.it	Doc. n°: IMAT AT-HD- EN Issue: 12/16 Page: 12/20
---	---	--	---

8.3.1.5.1. **Only for actuator with OPTION "B" (Figure 2):** screw the tie rods (A055) into the cylinder connection flange of the Power Module (A001), and insert the cylinder (A003) on the piston (A005)

8.3.1.6. Place the end cylinder flange (A002)

8.3.1.7. Progressively tighten all the screws or the nuts (AW21) or (AW06), depending by the optional module type.

8.3.1.8. **For actuator with external stroke adjustment - OPTION "B" (Figure 2):** screw the adjustment screw (A052) in the end cyl. flange (A002) with the adjustment nut (A053). Assemble the cover, if any, of the screw (A054) after the stroke adjustment (see par. 9).

8.3.1.9. **For actuator with central stroke adjustment - OPTION "A" (Figure 1 & Figure 3):** Screw in the Central Module the stop cap screw (CW09) with the nut (CW10); adjust the stroke (see par. 9).

8.3.2. Hydraulic module:

8.3.2.1. For the mounting the hydraulic cylinder follows the manual "IMAT AT-HD HYD"

8.3.2.2. Place the module gasket (C023) in the center of the sleeve.

8.3.2.3. From the inside of the Central Module, screw the hexagonal screws (AW03), between the Central Module side, lifting bracket in the hydraulic cylinder head flange.

8.3.2.4. Fix the piston shaft and screwing it into Central Module.

8.4. Assembling of the external group adjustment (only for Double Acting actuators with external stroke adj. - option "B" (Figure 2 & Figure 9).

8.4.1. Place the module gasket (C023) in the center of the sleeve

8.4.2. Screw the hexagonal screws (DW02) in the Central Module and in the end plate DA (D059) from the inside of the Central Module, if any.

8.4.3. Screw in the plate DA (D059) the screw (D056) with the nut (D057).

8.4.4. Screw the plug (D060) in the central sliding block (C019)

8.4.5. Adjust the stroke (see par. 9)

8.5. Closing of the cover and mounting of the position indicator

8.5.1. Make sure that the Power and Spring Modules are correctly assembled

8.5.2. Place the cover gasket (C022)

8.5.3. Place the cover (C002) on the Central Module and screw the hexagonal screws (CW08).


8.5.4. Fix the indicator to the Central Module screwing the hexagonal screws (CW12)

9. STROKE ADJUSTMENT

AIR TORQUE actuators AT-HD series, have, in both starting and ending position of the stroke, a stopper that allows to achieve an adjustment of +/-5° in both 0° and 90° positions.



Warning: Before proceeding with the stroke adjustment make sure that the actuator is in one of the two stroke positions, completely open (90°) or completely closed (0°). For a correct valve operation, it is important

 AIR TORQUE [®]	INSTALLATION, MAINTENANCE AND OPERATING INSTRUCTION MANUAL FOR AIR TORQUE ACTUATORS AT-HD SERIES	AIR TORQUE S.p.a. 24060 Costa di Mezzate Via dei Livelli di Sopra N° 8/11 Bergamo Italy Tel. +39 035 682299 Fax +39 035 687791 www.airtorque.it	Doc. n°: IMAT AT-HD- EN Issue: 12/16 Page: 13/20
--	---	--	---

that the travel stops of the actuator are correctly adjusted depending on valve type and function in order to avoid an incorrect valve operation or valve damage.

The instructions below refer to the stroke adjustment for actuators with standard rotation – clockwise to close "CW":

Depending on stroke adjustment option available, follow the instructions below to perform the actuator stroke adjustment

9.1. Stroke adjustment in closed position (0°) Figure 3 & Figure 4:

- 9.1.1. Unscrew the cover (A054), of the screw if any
- 9.1.2. Loosen the nut of the screw (A053), for Central stroke adjustment, loose the nut (CW10) of the right screw (counterclockwise to close for actuator seen from above).
- 9.1.3. Slightly pressurize Port 2 of the Power Module to remove the load from the adjustment screw (A052 or CW09), otherwise actuator damage may occur, and adjust the position of the stroke
- 9.1.4. Tighten the adjustment nut (A053 or CW10)
- 9.1.5. Relieve the pressure from the Power Module to test the stop position of the stroke (for Spring Return actuators)
- 9.1.6. If necessary, repeat the steps above
- 9.1.7. Screw the cover of the screw (A054), if any.


9.2. Stroke adjustment in open position (90°)

9.2.1. Double Acting actuator (Figure 9):

- 9.2.1.1. Loosen the nut of the screw (D057), for Central stroke adjustment, loose the nut (CW10) of the left stop cap screw (CW09). Actuator seen from above.
- 9.2.1.2. Slightly pressurize Port 4 of the Power Module to remove the load from the screw (D056 or CW09), otherwise actuator damage may occur, and adjust the position of the stroke
- 9.2.1.3. Tighten the adjustment nut (D057 or CW10)
- 9.2.1.4. Relieve the pressure from Port 4 from the Power Module and supply Port 2 to test the stop position of the stroke.
- 9.2.1.5. If necessary, repeat the steps above

9.2.2. Spring Return actuator Figure 3 & Figure 4:

- 9.2.2.1. Remove the plug (M062) and the lock screw (M063), if any
- 9.2.2.2. Make sure that the Power Module is not pressurized to ensure that the spring is fully extended; otherwise actuator damage may occur
- 9.2.2.3. If the central adjustment is available loosen the nut (CW10) of the left stop cap screw (CW09). Actuator seen from above.
- 9.2.2.4. Adjust the position of the stroke with the cap screw (M061) or, if Central stroke adjustment available, with the left stop cap screw (CW09). Actuator seen from above.

 AIR TORQUE [®]	INSTALLATION, MAINTENANCE AND OPERATING INSTRUCTION MANUAL FOR AIR TORQUE ACTUATORS AT-HD SERIES	AIR TORQUE S.p.a. 24060 Costa di Mezzate Via dei Livelli di Sopra N° 8/11 Bergamo Italy Tel. +39 035 682299 Fax +39 035 687791 www.airtorque.it	Doc. n°: IMAT AT-HD- EN Issue: 12/16 Page: 14/20
--	---	--	---


- 9.2.2.5. Slightly pressurize Port 2 of the Power Module with enough air so that a complete stroke can be obtained. Check the stop position of the stroke.
- 9.2.2.6. Screw the adjustment nut (CW10), if any.
- 9.2.2.7. If necessary, repeat the steps above
- 9.2.2.8. Screw the lock screw (M063) and the plug (M062), if any.

10. PERIODICAL CHECKS

- Check that the actuator strokes correctly and within the require cycle time.
- Check that the operating media supply pressure value is within the maximum allowable values for the actuator and for the application.
- Visually inspect the external modules of the actuator to detect damages if any,
- Check that there are no leakages in the pneumatic parts or hydraulic parts.
- Remove the dust and/or the dirt from all actuators surfaces because they could inhibit the cooling of the actuator thus increasing the actuator temperature above the maximum allowable limit.
- Check the surfaces of the actuator to detect scratches/absence of paint which could compromise the corrosion protection; if necessary, repair only with appropriate paints.

In the event that you notice some issues, the table below can help identifying problems and, where possible, solve them.

PROBLEM	CAUSE	REMEDY
Wrong rotation	Irregular supply	Check the system and ensure that the supply pressure is correct
	Lubricant missing	Disassemble, lubricate and reassemble
	Worn components	Disassemble, check the worn components and, if necessary, replace them
	Faulty valve	Check the valve documentation and contact the manufacturer
	Control instrumentation	Check the instrumentation documentation and contact the manufacturer
Not complete rotation	Wrong adjustment of the actuator stroke	Check the stop positions and, if necessary, repeat the adjustment
	Altered lubricant	Remove and replace the altered lubricant with a new one
	Extraneous parts within the actuator or leftover of the maintenance	Disassemble, remove the extraneous parts and reassemble
	Faulty valve	Check the valve documentation and contact the manufacturer
No torque output	Irregular supply	Check the system and ensure that the supply pressure is correct
	Supply pipe blocked, compressed or with sealing problems	Check all piping and fittings, remove any extraneous material or damaged components
	Power module piston sealing problems	Remove the Power Module (Air/Oil) and check the gasket, clean and reassemble; in case of defects, replace the gaskets
	Valve torque too high	Check the documentation and mounting of the actuator/valve
	Air exhaust hole blocked	Remove caps or extraneous objects from the exhaust hole

 AIR TORQUE [®]	INSTALLATION, MAINTENANCE AND OPERATING INSTRUCTION MANUAL FOR AIR TORQUE ACTUATORS AT-HD SERIES	AIR TORQUE S.p.a. 24060 Costa di Mezzate Via dei Livelli di Sopra N° 8/11 Bergamo Italy Tel. +39 035 682299 Fax +39 035 687791 www.airtorque.it	Doc. n°: IMAT AT-HD- EN Issue: 12/16 Page: 16/20
--	---	--	---

11. LIFTING AND HANDLING

It is recommended that the lifting and handling of the actuator must be done by qualified personnel and in accordance with the laws and regulations in force. Lift the actuators only with proper, adequate and allowed systems in relation to the actuator weight. The weight of the actuators is indicated on the Air Torque catalogue and in the related technical data-sheets.

During the lifting and the handling of the actuators, it is recommended to avoid clashes and/or accidental falls in order to avoid irreparable damages to the actuators and to compromise the functionality.

For safety handling prior and during the installation refer to data sheet HD21300E



Important! The Actuator lifting rings placed on the Power and Spring Modules, are designed for the lifting of the actuator only and not of the actuator plus the valve.

12. ACTUATOR INSPECTIONS (TO BE CARRIED OUT ON ACTUATOR ARRIVAL)

- If the actuator is shipped already assembled onto the valve, the setting of the actuator and control system (if available) should have been already performed by the valve manufacturer or automation center.
- If the actuator is shipped separately, the setting of the actuator and control system must be performed, while assembling the actuator on top of the valve.
- A visual inspection is recommended to detect any damage that actuator may have been subjected during transportation. If necessary, repair all damages to the top-coat.
- Check that the model, the serial number of the actuator and the performance data marked on the data-plate are in accordance with the order acknowledgement, test certificate and delivery note.
- Check that the fitted accessories (if available) comply with those listed in the order acknowledgement and the delivery note.

13. STORAGE INSTRUCTIONS

If the actuator is not intended for immediate use/installation, the following precautions must be taken:

- Store the actuator in a clean and dry place at a temperature not lower than -20°C (-4°F) and not more than $+40^{\circ}\text{C}$ ($+104^{\circ}\text{F}$).
- Keep the actuator in its original packaging.
- Do not remove the plastic caps from the air connections.
- Store the relevant technical documentation and this document.

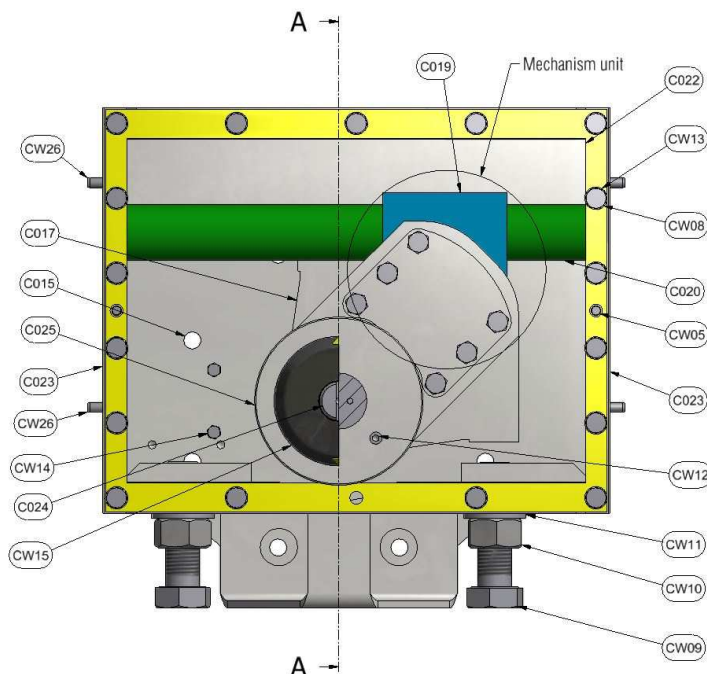
14. ACTUATOR ASSEMBLY AND PART LIST (Table 1 - Spare parts)
Central Module


Figure 2 - Central module STD

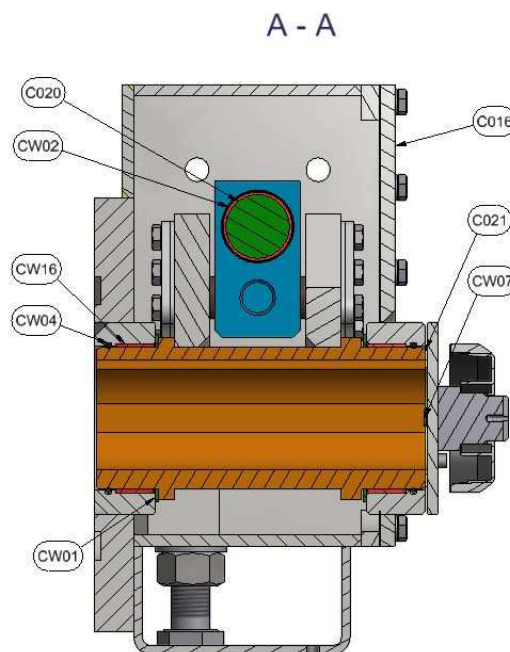


Figure 3 - Central module STD

Part Number	Q.Tà UNIT	Description	Mounted on Actuator
C015	1	HOUSING (CENTRAL MODULE)	ALL type
C016	1	COVER (CENTRAL MODULE)	ALL type
C017	1	SCOTCH YOKE	ALL type
C019	1	CENTRAL SLIDING BLOCK	ALL type
C020	1	GUIDE BAR	ALL type
C021*	1	GASKET (POSITIO INDICATOR)	ALL type
C022*	1	GASKET (COVER)	ALL type
C023*	1	GASKET (MODULE)	ALL type
C025	1	SHAFT COVER	ALL type
CW01*	2	THRUST BEARING	ALL type
CW02	2	ROD BUSHING (GUIDE BAR)	ALL type
CW04*	2	O-RING (SHAFT)	ALL type
CW05	2	PIN (COVER)	ALL type
CW07	2	SCREW (SHAFT EXTENSION)	ALL type
CW08	17	SCREW (COVER)	ALL type
CW09	2	SCREW (STROKE ADJ.)	ALL type
CW10	2	NUT (SCREW STROKE ADJ.)	For Central stroke Adj
CW11	2	WASHER (SCREW STROKE ADJ.)	For Central stroke Adj
CW12	2	SCREW (COVER SHAFT-YOKE)	For Central stroke Adj
CW13	17	WASHER (SCREW COVER)	ALL type
CW14	4	SCREW (ACCESSORY)	ALL type
CW15	1	POSITION INDICATOR	ALL type
CW16*	2	SHAFT BEARING	ALL type
CW26	4	PIN (ALIGNMENT MODULES)	ALL type

* Recommended Spare Parts for maintenance

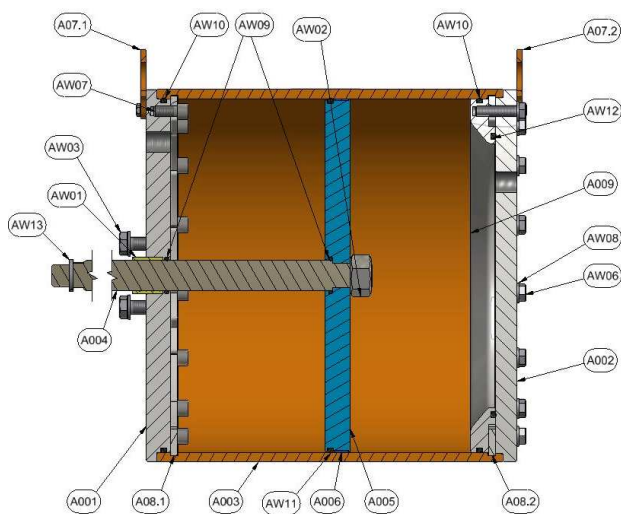
Power module


Figure 4 - Power module STD with central stroke adj. Model without tie roads

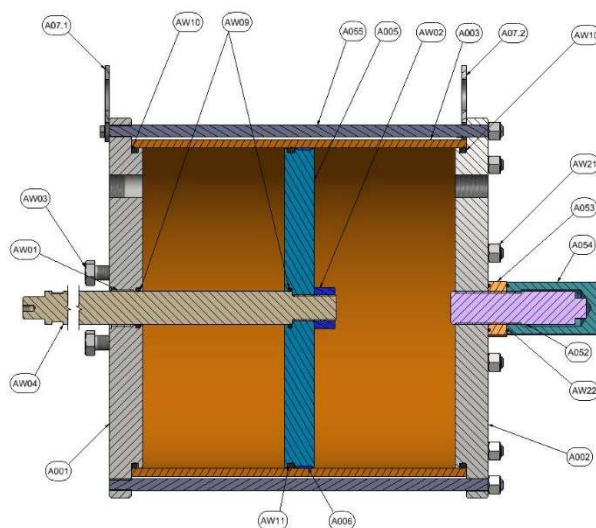


Figure 5 - Power module with external stroke adj. + tie roads

Part Number	Q.Tà UNIT	Description	Mounted on Actuator
A001	1	CYLINDER CONNECTION FLANGE	ALL type
A002	1	END CYLINDER FLANGE	ALL type
A003	1	POWER CYLINDER P. WITH O-Ring GROOVE	ALL type
A004	1	PISTON SHAFT	ALL type
A005	1	PISTON	ALL type
A006*	1	BEARING (Piston)	ALL type
A07.1	1	LIFTING BRACKET	ALL type
A07.2	1	LIFTING BRACKET	ALL type
A08.1	3	SECTOR RETAINER	For model without Tie roads (STD)
A08.2	3	SECTOR RETAINER	For model without Tie roads (STD)
A009	1	RETAINER FLANGE	For model without Tie roads (STD)
A052	1	SCREW FOR EXTERNAL STROKE ADJ	For model with external stroke adj.
A053	1	NUT FOR EXTERNAL STROKE ADJ.	For model with external stroke adj.
A054	1	COVER FOR EXTERNAL STROKE ADJ.	For model with external stroke adj.
A055	10	TIE ROADS	For model with Tie roads (STD)
AW01	1	SLEEVE (SHAFT POWER MODULE)	ALL type
AW02	1	NUT (PISTON)	ALL type
AW03	4	SCREW (POWER MODULE CONNECTION)	ALL type
AW06	12	SCREW (EXT. SECTOR RETAINER)	ALL type
AW07	12	SCREW (INT. SECTOR RETAINER)	ALL type
AW08	12	WASHER (SECTOR RETAINER)	ALL type
AW09*	2	O-RING (PISTON SHAFT)	ALL type
AW10*	2	O-RING (FLANGE)	ALL type
AW11*	1	O-RING (PISTON)	ALL type
AW12*	1	O-RING (RETAINER FLANGE)	For model without Tie roads (STD)
AW13	1	WASHER (PISTON SHAFT)	ALL type
AW14	1	FUNCTIONS LABEL	ALL type
AW15	1	LOGO LABEL	ALL type
AW21	10	NUT (TIE ROADS)	For model with Tie roads (STD)

* Recommended Spare Parts for maintenance

Spring module

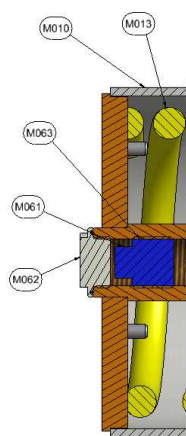


Figure 6 - Spring module with
External stroke adj

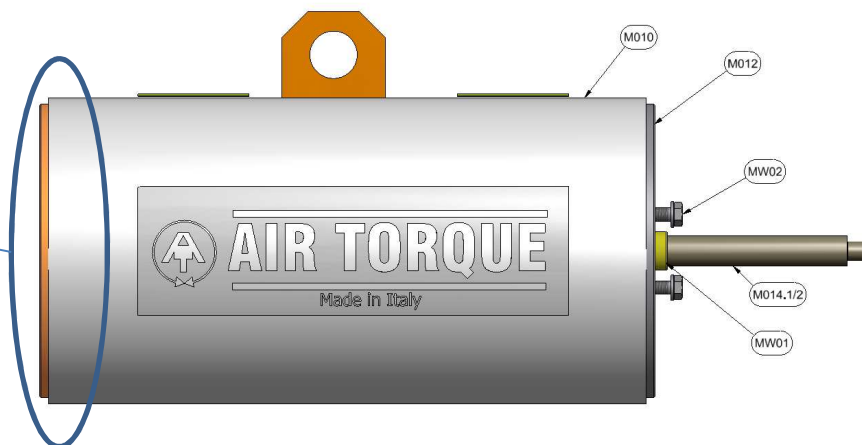
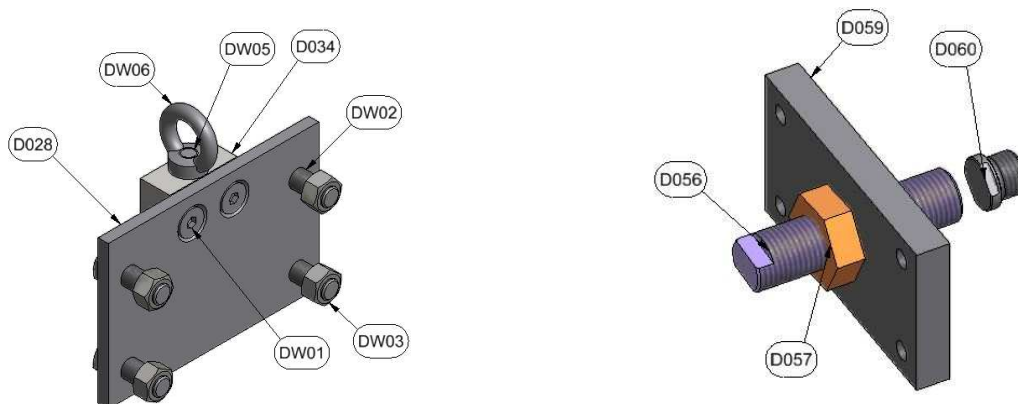


Figure 7 - Spring module STD with central stroke adj.

Part Number	Q.Tà UNIT	Description	Mounted on Actuator
M010	1	CARTRIDGE SPRING CYLINDER	ALL type
M011	1	SPRING COMPRESSION PLATE	ALL type
M012	1	CARTRIDGE FLANGE	ALL type
M013	1	SPRING	ALL type
M014.1/2	1	SHAFT (SPRING)	ALL type
M061	1	CAP SCREW FOR EXTERNAL STROKE ADJ.	For model with external stroke adj.
M062	1	PLUG FOR EXTERNAL STROKE ADJ.	For model with external stroke adj.
M063	1	LOCK SCREW FOR EXTERNAL STROKE ADJ.	For model with external stroke adj.
MW01*	1	SLEEVE (SHAFT SPRING)	ALL type
MW02	4	SCREW (CARTRIDGE CONNECTION)	ALL type
MW03	4	WASHER (CARTRIDGE CONNECTION)	ALL type
MW04	8	PIN (SPRING)	ALL type
MW05	1	LOGO LABEL	ALL type
MW06	1	LIFTING LABEL	ALL type
MW14*	1	O-RING FOR EXTERNAL STROKE ADJ.	For model with external stroke adj.

* Recommended Spare Parts for maintenance

Double Acting Actuator



Part Number	Q.Tà UNIT	Description	Mounted on Actuator
D028	1	DA FLANGE	ALL type
D034	1	EYEBOLT SUPPORT	ALL type
D056	1	SCREW FOR EXTERNA STROKE ADJ.	For model with external stroke adj.
D057	1	NUT FOR EXTERNAL STROKE ADJ.	For model with external stroke adj.
D059	1	PLATE FOR EXTERNAL STROKE ADJ	For model with external stroke adj.
D060	1	PLUG FOR EXTERNAL STROKE ADJ	For model with external stroke adj.
DW01	2	SCREW FOR DA EYEBOLT SUPPORT	ALL type
DW02	4	SCREW (CARTRIDGE CONNECTION)	ALL type
DW03	4	NUT (CARTRIDGE CONNECTION)	For model with external stroke adj.
DW04	4	WASHER (CARTRIDGE CONNECTION)	ALL type
DW05	1	SCREW FOR EYEBOLT	ALL type
DW06	1	EYEBOLT	ALL type

* Recommended Spare Parts for maintenance