

High performance double eccentric butterfly valves, metal seated.

AT.EX. Certified for zone 1 and 21

Available types:

- VF-930 wafer
- VF-933 lug

N°	PARTS	MATERIALS	SPECIFICATIONS	DETAILS
1	BODY	CARBON STEEL	ASTM A216 GR. WCB	-
		STAINLESS STEEL	ASTM A351 GR. CF8 ASTM A351 GR. CF8M	
2	DISC	STAINLESS STEEL	ASTM A351 GR. CF8	Disc Edge equipped with hard chrome plated
			ASTM A351 GR. CF8M	
3	RETAINER	STAINLESS STEEL	ASTM A351 GR. CF8 ASTM A351 GR. CF8M	-
4	GASKET	GRAPHITE	-	-
5	METAL SEAT	STAINLESS STEEL	AISI 316	-29°C / +315°C (*)
			INCONEL 718	
6-7	BUSHING	STAINLESS STEEL	ASTM A182 GR.F316	-
8-9	WASHER	STAINLESS STEEL	ASTM A240 GR.316	-
			ASTM A182 GR.F304	
10	STEM	STAINLESS STEEL	ASTM A182 GR.F316	Stem equipped with hard chrome plated
			ASTM A564 GR.630	
			ASTM A182 GR.F316	
11	PIN	STAINLESS STEEL	ASTM A182 GR.F316	-
12	THRUST RING	STAINLESS STEEL	ASTM A240 GR.316	-
13	SEAL	GRAPHITE	-	-
14	BOTTOM COVER	STAINLESS STEEL	ASTM A351 GR. CF8 ASTM A351 GR.CF8M	-
		CARBON STEEL	ASTM A216 GR.WCB	
15	GLAND PACKING	GRAPHITE	-	-
16	GLAND	STAINLESS STEEL	ASTM A351 GR.CF8	-
			ASTM A351 GR.CF8M	
17	YOKE	DUCTILE IRON	ASTM A536 GR. 65-45-12	WCB is only available for: F07/F05, F10/F07, F12/F10, F14/F12, F16/F14 A536 is only available for: F16, F25, F30, F35, F40
		CARBON STEEL	ASTM A216 GR.WCB	
		STAINLESS STEEL	AISI 316	
18	STUD	STAINLESS STEEL	ASTM A193 GR.B8	-
19	NUT	STAINLESS STEEL	ASTM A194 GR.8	-
20	BOLT	STAINLESS STEEL	ASTM A193 GR.B8	-

(*) Working temperature must always be related to working pressure and chemical composition of fluid.

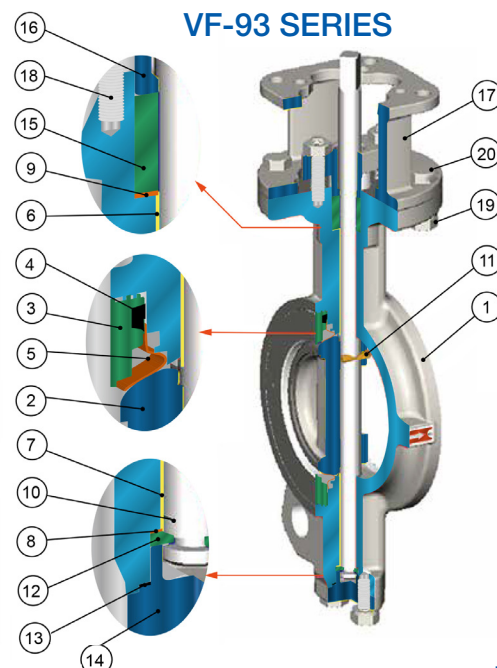

ARA[®]
PNEUMATIK

ul. Wyciągowa 38, 53-012 Wrocław
tel. 71 364 72 82, ara@arapneumatik.pl
www.arapneumatik.pl



Technical details

- The valve has a double eccentric disc design with offset seat; valve seat is designed for full pressure, bi-directional, bubble tight sealing.
- The one-piece shaft design is blow-out proof and is equipped with anti-static devices.
- The patented seat retainer ring, attached without bolts, allows complete uninterrupted seal face.
- Seat: metal (AISI 316, INCONEL 718).
- Face to face according to ISO 5752, API 609.
- Body hardness according to ASME B 16.34.
- Metal seat design for leakage rated ANSI FCI 70-2 2003 table 1 Class IV.
- Lever operated or gear operated (from DN 50 to DN 150), only gear operated (from DN 200 to DN 600).
- Upper flange according to ISO 5211.
- Suitable for PN 16/25 and ANSI 150 flanges.
- Rating PN 25.
- Hydraulic pressure tests according to ISO 5208.
- Body tested at 38 bar.
- Seat tested at 28 bar.
- Pneumatic seat pressure test according to ISO 5208.
- Seat tested at 7 bar.
- Working temperature: -29°C / +315°C.

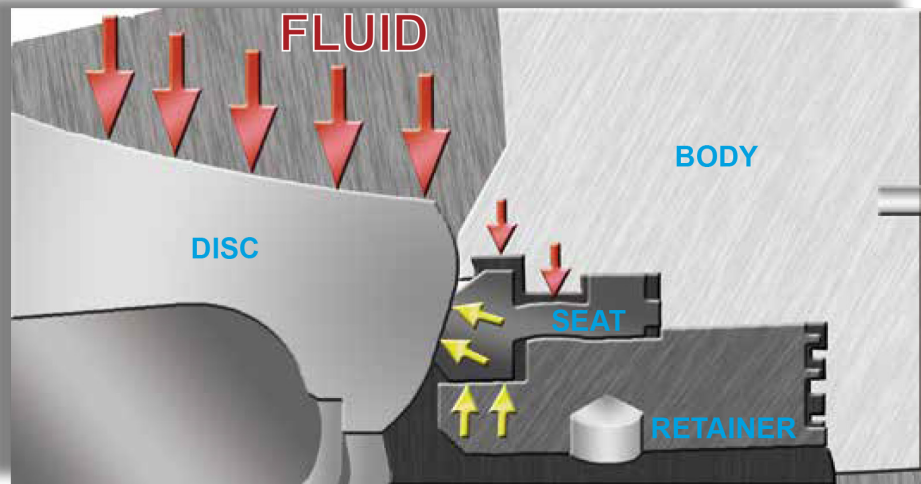
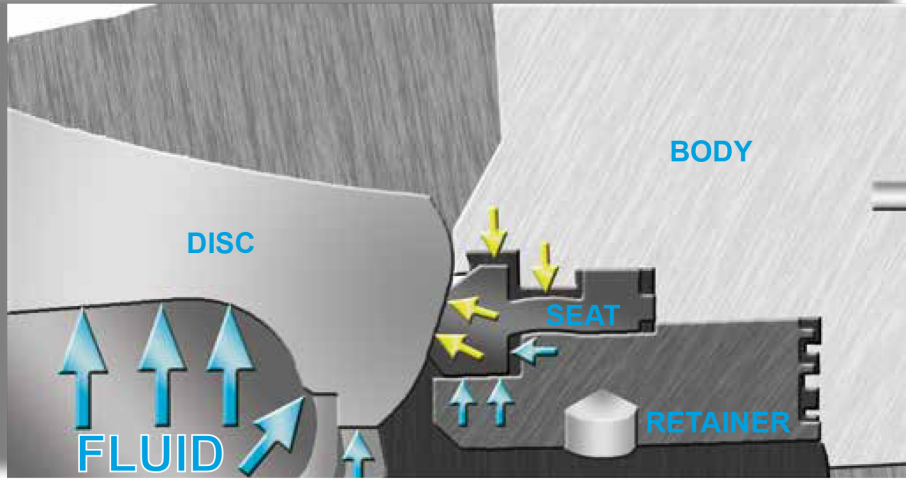

Special design of floatable retainer and seat cause the better sealing effect, bi-directional function, and increase the life cycle upper to two million times.

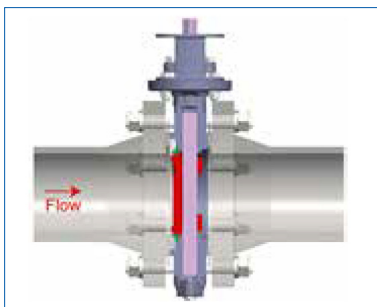

The seals flow can be executed in both directions. The following advantages can be assured while the suggested flow directions is used:

- Minimal start-up torque.
- Reduced seat wear.
- No direct contact between the fluid and the seat.

BUTTERFLY VALVES

VF-93

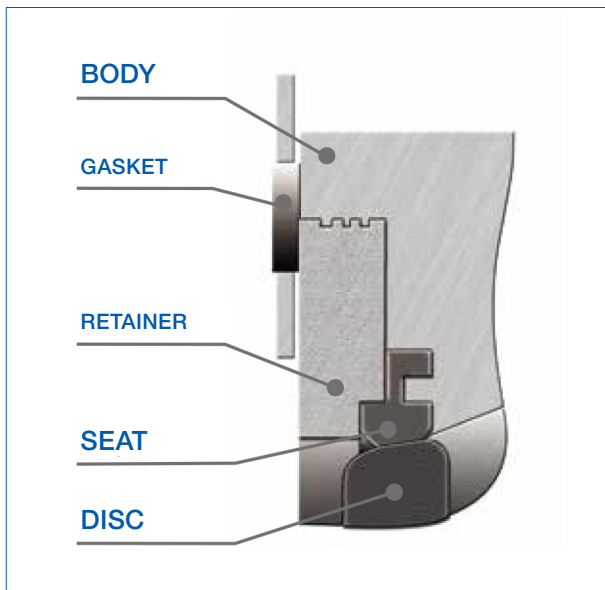
 II 2 G/D T.F. 02

PATENT DESIGN

Special twin thread design between body and retainer to offer:

- 1) Wider sealing face between flanges.
- 2) 100% sealing between retainer and body.
- 3) When long time storage, valve was in fully closed position and the seat ring was fix by retainer, it will not cause PTFE enlarge.

NOTE:

retaining ring must be up stream for dead end service.

CONVENTIONAL DESIGN

- 1) The seat retainer of some brands extended as a flange surface, which has to be sealed by a gasket and increase a risk of leakage.
- 2) Most of the seat retainer was fixed by socket bolts, which caused reducing sealing face between flanges and increase a risk of leakage.
- 3) When long time storage, valve was in fully closed position and the seat ring was fix by retainer, it may cause PTFE enlarge and leakin when service.

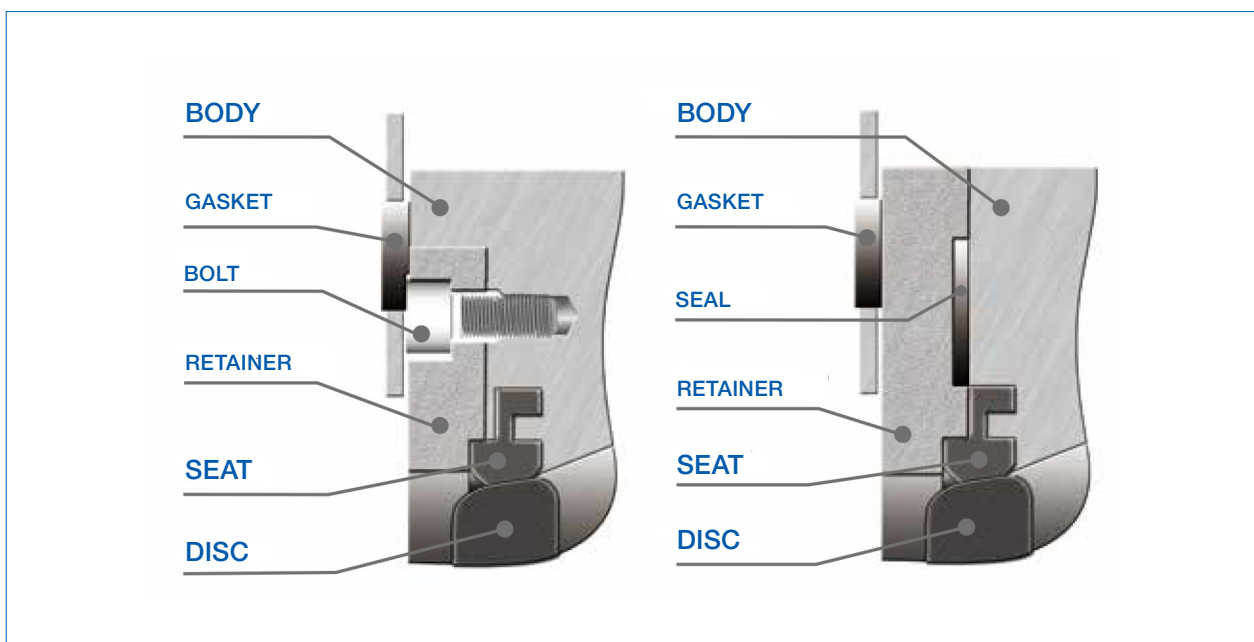

DIMENSIONS VF-930 WAFER TYPE

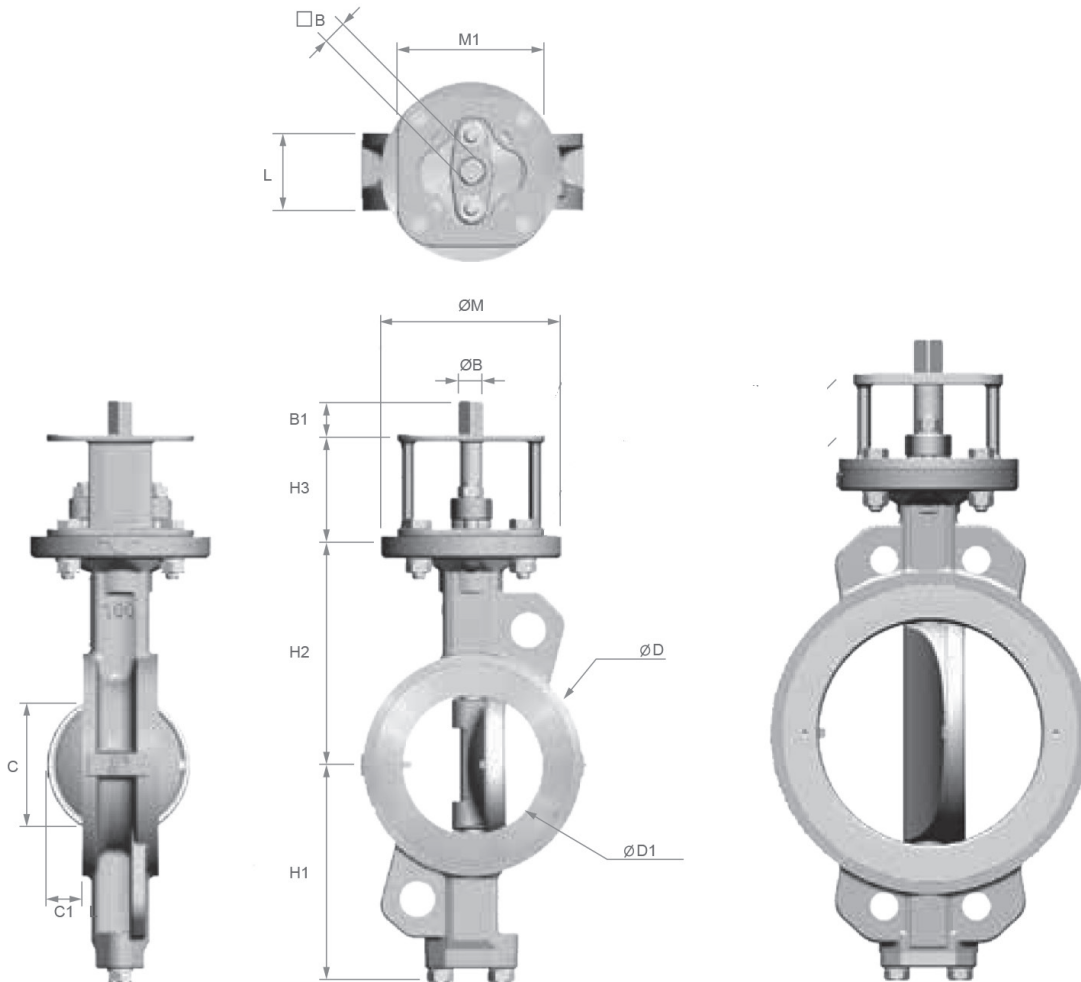

DIMENSIONS (mm)																		
SIZE		DIMENSIONS								ISO 5211 MOUNTING FLANGE				SHAFT END			WEIGHT	
										Valve		Yoke						
DN	Inch	L	H1	H2	H3	ØD	ØD1	C	C1	Type	ØM	Type	M1	ØB	B	B1	Kg	
50	2"	43	99	118	60	92	37	49.5	2	F07	90	F07	F05	70	14	11	18	3.9
65	2.1/2"	46	110	125	60	108	63	62.3	15	F07	90	F07	F05	70	14	11	18	4.5
80	3"	47	128	140	70	126	78	65.9	22	F10	125	F10	F07	102	18	14	23	7
100	4"	53	150	157	70	153	95	93	25	F10	125	F10	F07	102	18	14	23	9
125	5"	57	163	170	70	184	118	120	36	F10	125	F10	F07	102	22	17	23	12
150	6"	56	176	185	70	212	143	149	50	F10	125	F10	F07	102	22	17	23	13.5
200	8"	62	206	220	80	268	187.6	196	70	F12	150	F12	F10	125	25	19	28	22
250	10"	68	238	260	100	326	235.5	243	90	F12	150	F12	F10	125	28	22	28	32
300	12"	78	269	290	100	375	282	289	106	F14	175	F14	F12	160	35	27	28	48
350	14"	78	306	326	120	416	322	329	125	F14	175	F16	F12	160	36	27	37	65
400	16"	102	342	370	120	476	371	377	140	F16	210	F16	F14	195	48	36	47	107
450	18"	114	370	395	120	534	418	423	157	F16	210	F16	F14	195	48	36	47	130
500	20"	127	399	430	150	588	466	471	177	F16	210	F16	F14	195	60	46	56	163
600	24"	154	455	490	150	692	570	572	210	F25	300	F16/25	-	350	60	46	56	278

DIMENSIONS VF-933 LUG TYPE

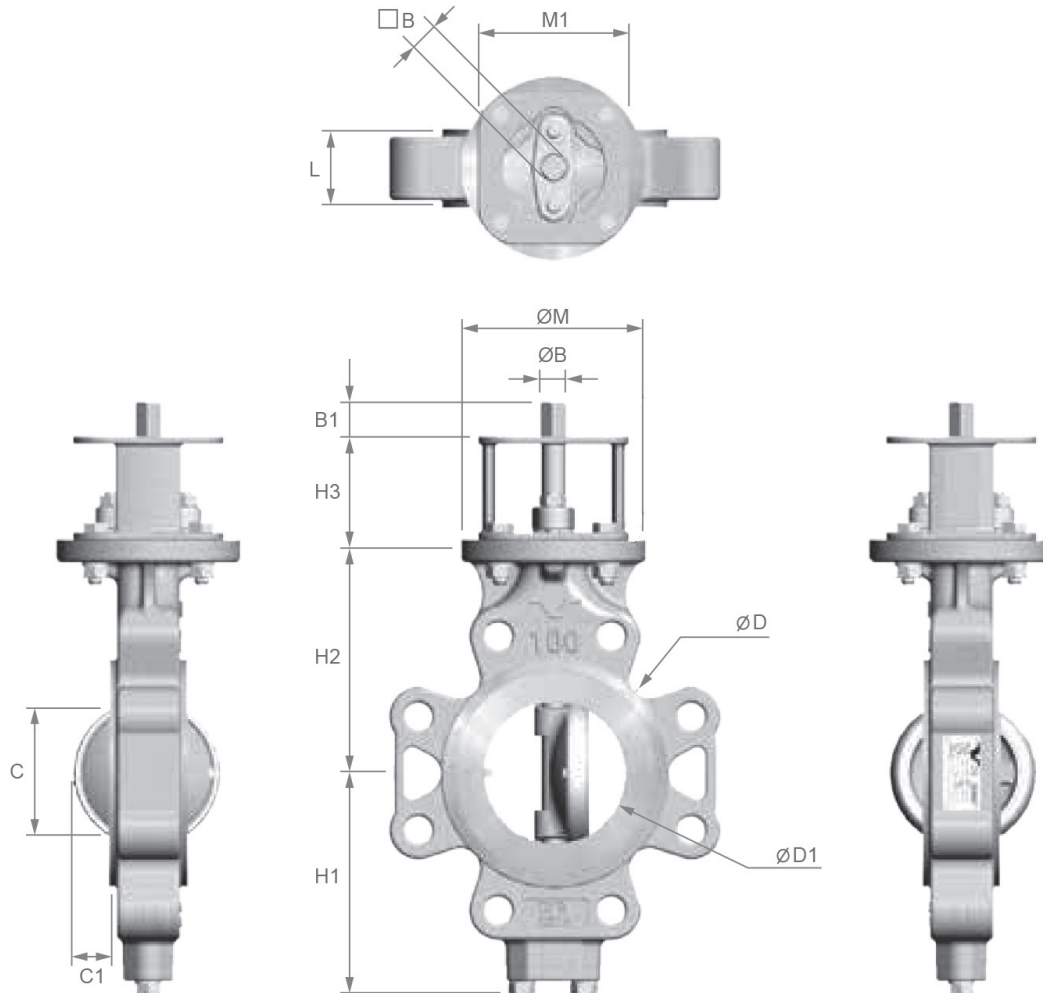

DIMENSIONS (mm)

SIZE		DIMENSIONS								ISO 5211 MOUNTING FLANGE				SHAFT END			WEIGHT	
										Valve		Yoke						
DN	Inch	L	H1	H2	H3	ØD	ØD1	C	C1	Type	ØM	Type	M1	ØB	B	B1	Kg	
50	2"	43	99	118	60	92	37	49.5	2	F07	90	F07	F05	70	14	11	18	4.9
65	2.1/2"	46	110	125	60	108	63	62.3	15	F07	90	F07	F05	70	14	11	18	5.5
80	3"	47	128	140	70	126	78	65.9	22	F10	125	F10	F07	102	18	14	23	8.5
100	4"	53	150	157	70	153	95	93	25	F10	125	F10	F07	102	18	14	23	14
125	5"	57	163	170	70	184	118	120	36	F10	125	F10	F07	102	22	17	23	18
150	6"	56	176	185	70	212	143	149	50	F10	125	F10	F07	102	22	17	23	19.5
200	8"	62	206	220	80	268	188	196	70	F12	150	F12	F10	125	25	19	28	31
250	10"	68	238	260	80	326	236	243	90	F12	150	F12	F10	125	28	22	28	47
300	12"	78	269	290	100	375	282	289	106	F14	175	F14	F12	160	35	27	28	67
350	14"	78	306	326	100	416	322	329	125	F14	175	F14	F12	160	36	27	37	81
400	16"	102	342	370	120	476	371	377	140	F16	210	F16	F14	195	48	36	47	143
450	18"	114	370	395	120	534	418	423	157	F16	210	F16	F14	195	48	36	47	163
500	20"	127	399	430	120	588	466	471	177	F16	210	F16	F14	195	60	46	56	230
600	24"	154	455	490	150	692	570	572	210	F25	300	F16/25	-	300	60	46	56	377

TORQUE (Nm)							
SIZE		DIFFERENTIAL PRESSURE (kg/cm ²)					
DN	Inch	0	5	10	15	20	25
50	2"	39	49	59	65	75	82
65	2.5"	46	56	78	102	127	147
80	3"	56	71	88	118	140	167
100	4"	78	102	122	157	178	216
125	5"	108	140	154	182	211	248
150	6"	137	169	199	232	265	319
200	8"	206	255	294	333	372	434
250	10"	265	333	402	470	578	686
300	12"	372	461	559	735	931	1176
350	14"	539	676	843	1019	1245	1421
400	16"	764	990	1225	1490	1764	2058
450	18"	902	1107	1441	1803	2205	2871
500	20"	1294	1411	1882	2352	2940	3410
600	24"	1529	1764	2176	2940	407	6076

Including 30% safety factor. To calculate the correct coupling with actuators please contact our technical department.

CV VALUES										
DN	% OPENING DISC									
mm	10%	20%	30%	40%	50%	60%	70%	80%	90%	100%
50	4	12	26	39	72	126	153	204	233	153
65	7	23	45	66	122	214	258	345	393	259
80	10	34	68	101	185	324	391	523	596	392
100	11	41	72	110	214	375	416	541	575	613
125	17	53	106	157	290	506	611	816	931	958
150	24	77	152	226	417	728	880	1176	1340	1379
200	42	137	271	402	546	765	993	1303	1450	1750
250	125	305	492	279	554	768	984	2060	2440	2667
300	170	415	669	965	1300	1755	3059	3454	3849	4366
350	222	506	796	1165	1614	2241	3122	4230	5360	5964
400	172	537	902	1324	1904	2485	3703	5395	6887	7762
450	392	946	1456	2040	2816	3918	5416	7061	8535	9354
500	513	1197	1834	2558	3505	4943	7188	9097	11011	11824
600	845	1861	2752	3911	5501	7664	10840	14424	18347	19862

CV = U.S. gallon/min at pressure of 1 psi with water at 20°C
 CV = 1,17 Kv, Kv = m³/h at pressure of 1 kg/cm² with water at 20°C

BUTTERFLY VALVES

VF-93

CE Ex II 2 G/D T.F. 02

SUGGESTED BOLTS FOR UNI PN 16/25 – ANSI 150 FLANGES

WAFER

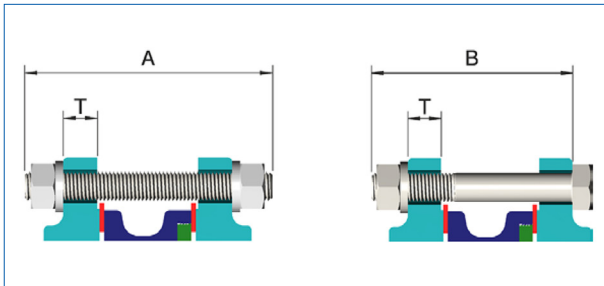

LUG

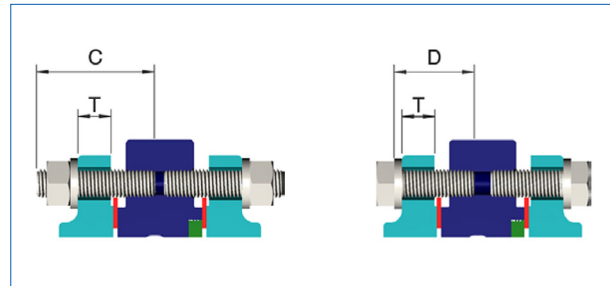

SIZE		ASME B 16.5 150LB						PIN 16					PIN 25						
DN	Inch	Bolts	A	B	C	D	T	Bolts	A	B	C	D	T	Bolts	A	B	C	D	T
50	2	5/8"	135	125	65	50	20	M16	130	120	65	45	20	M16	130	125	70	50	22
65	2.5	5/8"	140	125	70	50	22	M16	135	120	70	45	20	M16	140	125	70	50	22
80	3	5/8"	145	130	70	50	24	M16	135	120	70	45	20	M16	145	130	75	50	24
100	4	5/8"	150	135	75	55	24	M16	145	130	75	50	22	M20	160	140	80	55	24
125	5	3/4"	165	145	80	55	24	M16	150	135	75	50	22	M24	180	155	90	60	26
150	6	3/4"	165	145	85	55	25	M20	165	140	80	55	24	M24	180	155	90	60	28
200	8	3/4"	175	155	90	60	28	M20	165	145	85	55	24	M24	190	165	95	65	30
250	10	7/8"	190	170	95	65	30	M24	190	165	95	60	26	M27	210	180	105	70	32
300	12	7/8"	205	180	100	70	32	M24	205	180	100	70	28	M27	220	195	110	75	34
350	14	1"	220	195	110	75	35	M24	210	185	105	70	30	M30	235	205	120	80	38
400	16	1"	245	220	125	80	37	M27	240	215	120	80	32	M33	270	240	135	95	40
450	18	1-1/8"	270	240	135	90	40	M27	270	240	135	90	40	M33	300	265	150	105	48
500	20	1-1/8"	290	260	145	90	43	M30	300	270	150	100	44	M33	310	280	155	105	48
600	24	1-1/4"	340	305	170	100	48	M33	355	320	175	110	54	M36	370	330	185	120	58



Electrical or pneumatic actuators, positioners, limit switches, solenoid valves and other equipments. Assembled on VALSAR butterfly valves.

ARA[®]
PNEUMATIK

ul. Wyścigowa 38, 53-012 Wrocław
tel. 71 364 72 82, ara@arapneumatik.pl
www.arapneumatik.pl

