

VT

Electric actuator

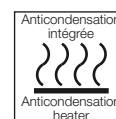

UK Installation and Operation Manual



Index

General information	3
– Description	
– Transport and storage	
– Maintenance	
– Warranty	
– Return of goods	
– Safety instructions	
Actuators description	4
Dimensions	5
Emergency manual override	5
Electric wiring	6
– Warnings	
– Wiring Instructions	
– Electric diagrams	
Technical data	10

This product meets the European Directive 2012/19/UE about electrical and electronic equipment (DEEE). It mustn't be mixed with common waste. Please, recycle or dispose of them according to your country laws.

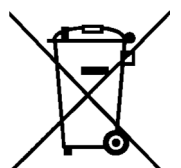

DESCRIPTION

These electric actuators have been designed to perform the control of a valve with 90° rotation. Please consult us for any different application. We cannot be held responsible if the mentioned actuators are used for any other purpose.

TRANSPORT AND STORAGE

- The forwarding agents being held as responsible for damages and delays of the delivered goods, the consignees are obliged to express if applicable their reserves, prior to accept the goods. The goods delivered directly ex works are subject to the same conditions.
- The transport to the place of destination is carried out by using rigid packing material.
- The products must be stored in clean, dry, and ventilated places, preferably on appropriate palettes or shelves. Actuators should not be stored upside down.

MAINTENANCE

- Maintenance is ensured by our factory. If the supplied product does not work, please check the wiring according to the electric diagram as well as the power supply of the electric actuator in question.
- For any question, please contact our after-sales service.
- To clean the outside of the actuator, use a lint and soapy water. DO NOT USE ANY CLEANING PRODUCT WITH SOLVENT OR ALCOHOL.

WARRANTY

- Our products are thoroughly tested and set in factory.
- These products are 3-year warranty from the manufacturing site delivery date or 50,000 actuations against all types of manufacturing and material faults (operating time and model class according to standard CEI34).
- The said guarantee covers solely replacement or – at our full sole discretion - repair, free of charge, of those components of the goods supplied which in our sole view present proven manufacturing defects.
- This warranty excludes any damage due to normal product usage or friction and does not include any modified or unauthorized repair for which we will not accept any request for damage (either direct or indirect) compensation (for full details see our website).
- The guarantee does not cover the consequences of breakdown and excludes any payments for indemnities. The accessories, consumables (batteries...) and adaptations are excluded from the guarantee. In the case where a customer has not proceeded to payments within the agreed period, our guarantee will be suspended until the delayed payments have been received and with the consequence that this suspension will not prolong the guarantee period in any case.
- All sales subject to our terms to be found on our website.

RETURN OF GOODS

- When the actuator receives his actuator, he must check its conformity according to its definition.
- The acceptance of the goods by the purchaser disclaims the supplier of all responsibility if the purchaser discovers any non-conformity after the date of acceptance. In such case, the repair cost will be borne by the purchaser who will also exclusively bear all financial consequences of any resulting damages. Returned goods will only be accepted if our prior agreement has been given to this procedure : the goods must be sent free of all cost and being shipped solely and in their original packing. The returned goods will be credited to the purchaser with a reduction of 40% on the unit's price charged in accordance with the original invoice of the returned goods.

SAFETY INSTRUCTIONS



(To be read prior to the installation of the product)

- Any intervention must only be carried out by a qualified electrician or other person instructed in accordance with the regulations of electric engineering, safety, and all other applicable directives.
- Strictly observe the wiring and set-up instructions as described in the manual: otherwise, the proper working of the actuator can not be guaranteed anymore. Verify that the indications given on the identification label of the actuator fully correspond to the characteristics of the electric supply.

MOUNTING INSTRUCTIONS



(To be read prior to the installation of the product)

- Do not mount the actuator less than 30 cm from an electromagnetic disturbance source.
- Do not mount the actuator « upside down ».
- Do not position the equipment so that it is difficult to operate the disconnecting device.
- Respect all safety rules during fitting, dismantling and porting of this apparatus.

Actuators description

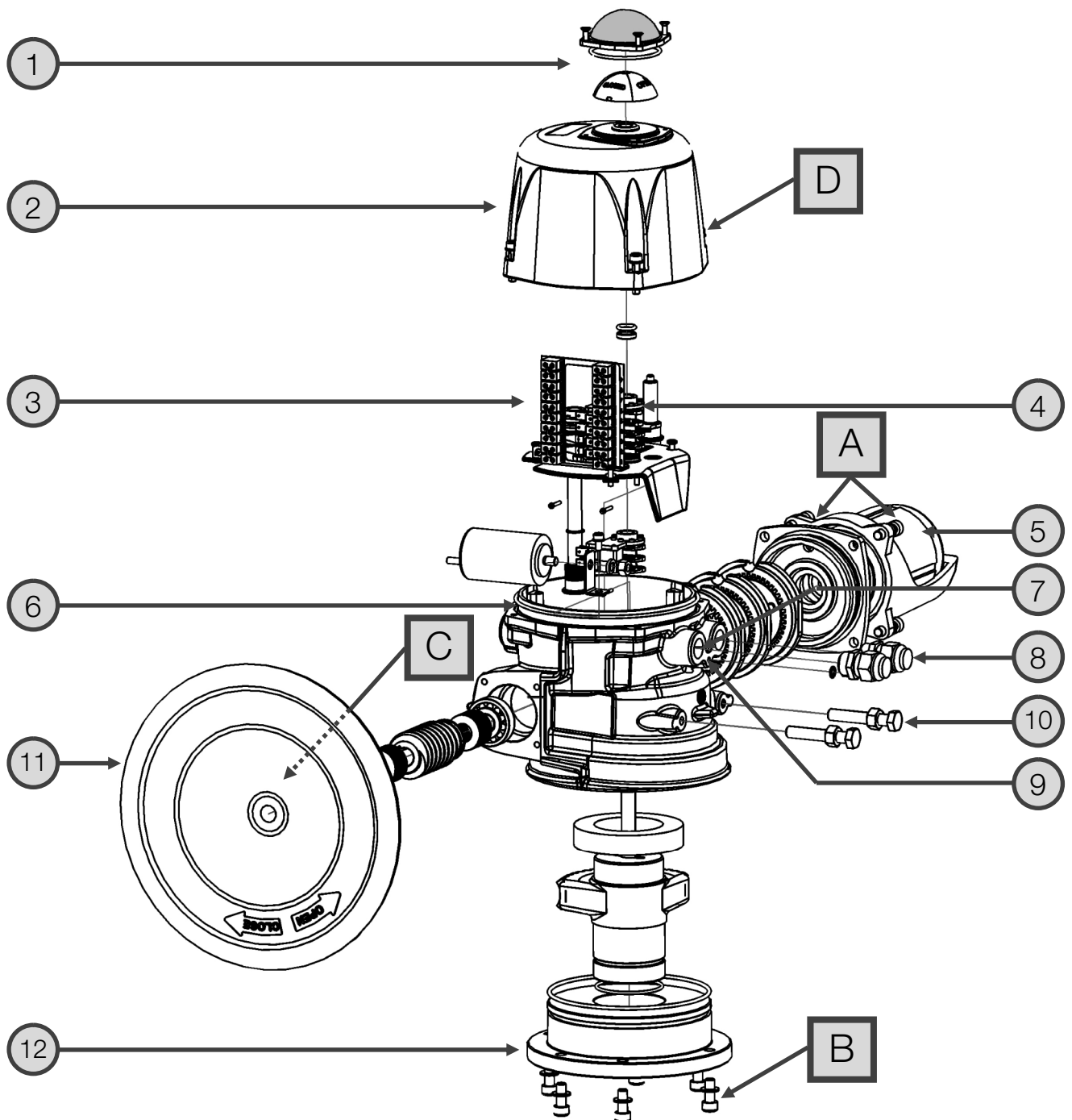

Part	Description	Part	Description
1	Position indicator	7	M20x1,5 treated holes (1/2" NPT en option)
2	Cover	8	Cable glands
3	Detection switches Motor + feedback	9	Earth screw
4	Cams	10	Mechanical stops
5	Motor	11	Wheel
6	O-ring	12	F10-F12 cast iron plate
A	CHC M8 x 30 A2-70	B	CHC M8 x 20 A2-70
C	CHC M6 x 16 A2-70	D	CHC M6 x 30 Class 12.9

Dimensions

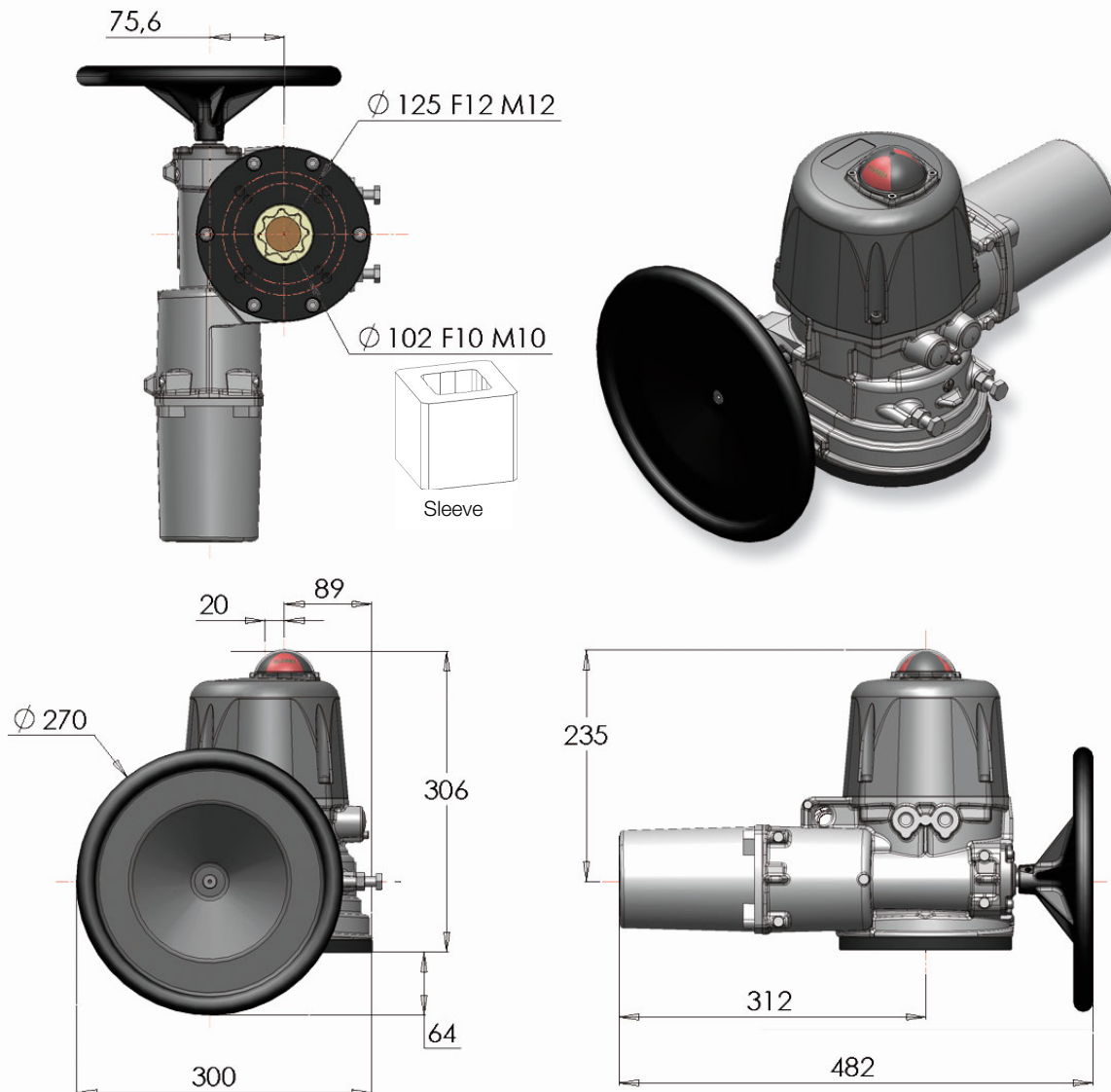

Star (mm)	Depth (mm)	ISO F connection	Diameter (mm)	Treated M	Depth (mm)	Screws number
36	41	F10	102	M10	25	4
		F12	125	M12	30	4
Screws maximal length (+ valve connection plate height) (mm)						
					20mm	
					25mm	

Emergency manual override

- The actuator is set to its closed position in our factory and operates in electric priority. Ensure that the power supply is cut off prior to manually operation. No declutching is required, the hand wheel has simply to be turned (appendix p.14 mark 11): Anti-clockwise to open.
- The end mechanical stops are preset to 90° and stuck (Tubetanche Loctite 577 or equivalent). It is possible to adjust then by moving the 2 screws (appendix p.14 mark 10) but you need to stick them again in order to ensure a proper sealing.

Mounting / dismantling of the cover and position indicator

- For the wiring and setting of the actuator, it is necessary to remove the cover.
- Mounting of the cover (appendix p.14 mark 2) : make sure that the seal ring (appendix p.14 mark 6) is correctly placed in its position, grease of the flame path (Molydal 3790 grease or equivalent), mount the cover and tighten the 4 screws M6 (appendix p.14 mark D, torque : 6Nm).
- Mounting of the position indicator (appendix p.14 mark 1) : mount the seal ring and the indicator then the window with the 4 screws M4.



Switch power off before using the manual override

Electric wiring

Warnings



- Use only one relay for one actuator.
- As stipulated in the applicable regulation, the connection to earth contact is compulsory for devices with working voltages exceeding 42V.
- The actuator is being always under power, it must be connected to a disconnection system (switch, circuit breaker) to ensure the actuator's power cut. The latter must be closed to the actuator, easy to reach and marked as being the disconnecting device for the equipment.
- The temperature of the terminal can reach 90°C.
- To optimize the installation security, please connect the failure feedback signal (D1 and D2).
- In case of long cables, please note the induction current shall not exceed 1mA.
- The actuator can tolerate temporary overvoltage of the electrical grid up to $\pm 10\%$ of its nominal system operating voltage.
- The selection of the cables and cable glands: the maximal operating temperature of the cables and cable-glands must be at least 110°C.
- It is necessary to connect all actuators to an electrical cabinet. The power supply cables must have the RATED diameter for the maximum current supported by the actuator and comply with IEC 60227 or IEC 60245 standards.
- In order to ensure the IP68 tightness, the cable glands must be used (7 to 12mm cable). Otherwise, the cable glands must be replaced by a ISO M20 IP68 cap. A cable gland is tight when it has been tighten by one turn ahead of contact between rubber seal and nut.
- The auxiliary limit switches must be connected with rigid wires. If the applied voltage is higher than 42V, the user must foresee a fuse in the power supply line.
- The feedback switches must be powered with the same voltage. The reinforced insulation of the motor control allows voltages up to 250V AC/DC.

Electric wiring: instructions

SUPPLY AND CONTROL WIRING

- Remove the position indicator, unscrew the four screws and take off the cover.
- Ensure that the voltage indicated on the actuator ID label corresponds to the voltage supply.
- Connect the wires to the connector in accordance with the required control mode. (see diagram p. 18/19)
- To ensure the correct functioning of the anti condensation heater, the actuator must be always supplied

WIRING OF THE FEEDBACK SIGNAL

Our actuators are equipped with two simple limit switch contacts normally set either in open position, either in closed position (see wiring diagram DSBL0491 (230V) and DSBL0492&DSBL0493 (400V) inside the cover). As per factory setting, the white cam is used to detect the open position (FC1) and the black cam is used to detect the closed position (FC2).

The auxiliary limit switches must be connect with rigid wires. If the applied voltage is higher than 42V, the user must foresee a fuse in the power supply line.

- Unscrew the right cable gland and insert the cable.
- Remove 25mm of the cable sheath and strip each wire by 8mm.
- Connect the wires to the terminal strip in accordance with the diagram 18/19
- Tighten the ATEX/IECEX and IP68 cable gland (Ensure that it's well mounted to guaranty the proofness).

SETTING OF END LIMIT SWITCHES

The actuator is pre-set in our factory. Do not touch the two lower cams in order to avoid any malfunctioning or even damage to the actuator.

- To adjust the position of the auxiliary contacts, make rotate the two superior cams by using the appropriate wrench.
- Re-mount the cover and fasten the four screws.

230V electric diagram



- The terminal temperature can reach 90°C
- The used wires must be rigid (feedback voltages: 4 to 250V AC/DC)

Rep.	Designation	Rep.	Designation	Rep.	Designation
FCO	Open limit switch	FCF	Close limit switch	TLO	Torque switch : opening
FC1	Auxiliary limit switch 1	FC2	Auxiliary limit switch 2	TLF	Torque switch : closing
C	Capacitor	F	Motor thermoswitch	H	Anti-condensation heater
M	Motor	VL	Purple	MR	Brown
RG	Red	NR	Black	BU	Blue
OG	Orange	BC	White	D1/D2	Failure report terminal (230V AC max / 5 A)

POWER SUPPLY AND CONTROL

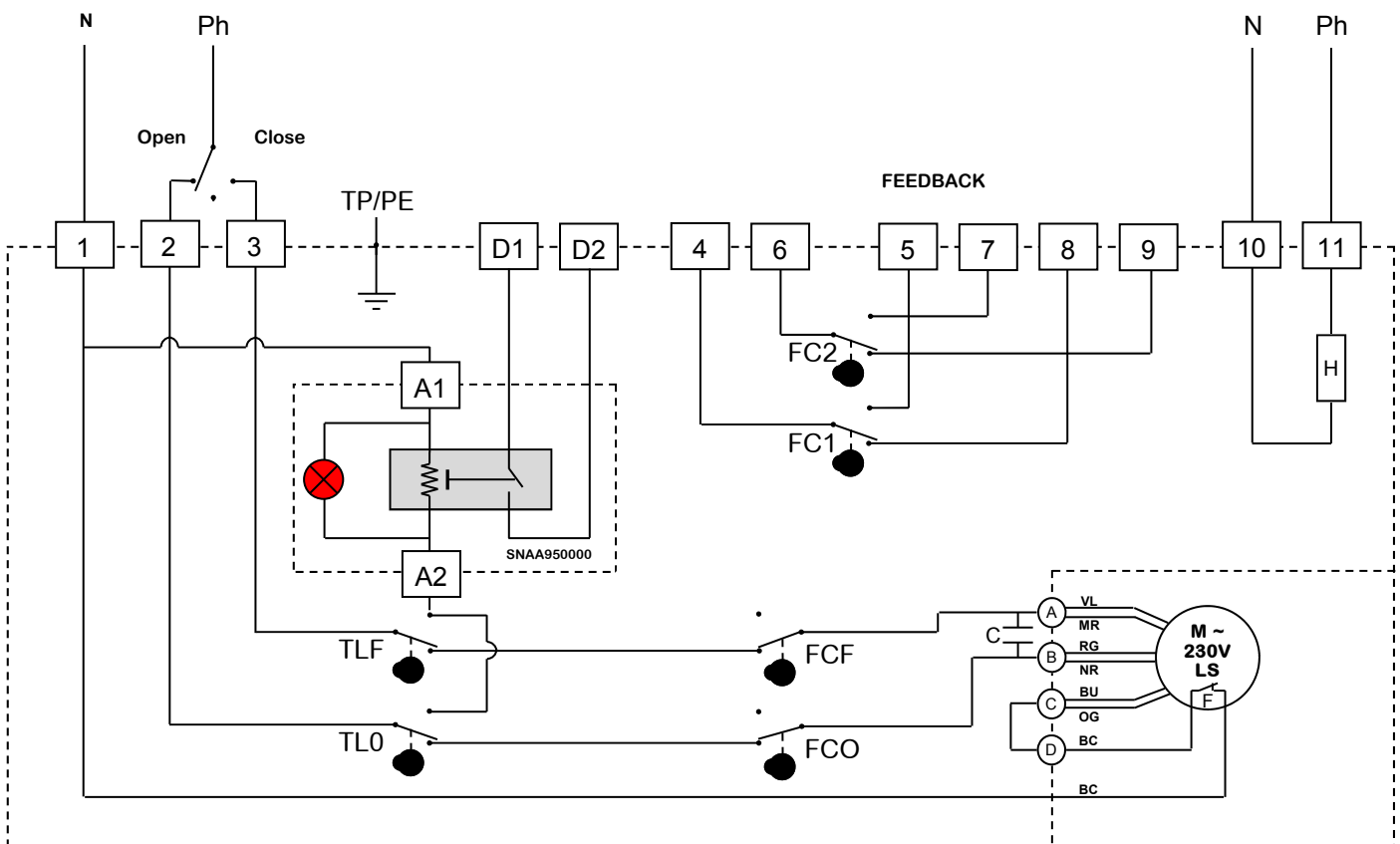

3-phase 400V electric diagram



- The terminal temperature can reach 90°C
- The used wires must be rigid (feedback voltages: 4 to 250V AC/DC)

Rep.	Designation	Rep.	Designation	Rep.	Designation
FC0	Open limit switch	FCF	Close limit switch	TLO	Torque switch : opening
FC1	Auxiliary limit switch 1	FC2	Auxiliary limit switch 2	TLF	Torque switch : closing
BC	White	F	Motor thermoswitch	H	Anti-condensation heater
M	Motor	VL	Purple	MR	Brown
RG	Red	NR	Black	BU	Blue
OG	Orange	D1/D2	Failure report terminal (230V AC max / 5 A)		

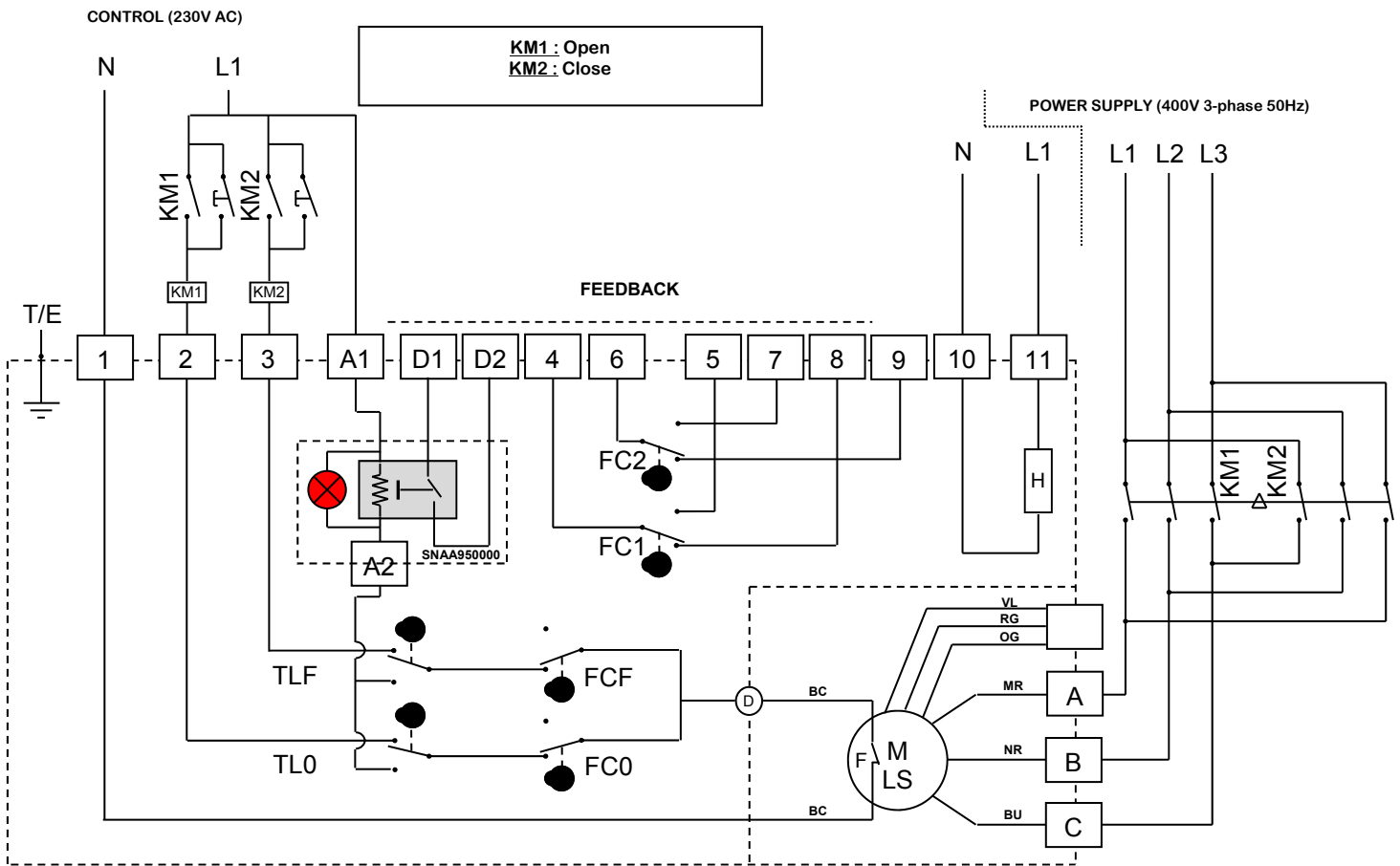

The motor power supply is wired on bistable three-phase relay (not delivered).
If working inverted, invert 2 phases of motor.

Technical data

VT600

VT1000

Location

Materials	Housing: Aluminium + EPOXY paint / cover: PA6 UL 94 V-0 or Aluminium + EPOXY paint Drive : Steel + Zn treatment / Axles and screws : Stainless steel	
Sealing	IP68	
Environment	Both inside and outside (wet environments possible)	
Operating temperature	-20°C to +70°C	
Operating altitude	Up to 2000m	
Hygrometry	maximum relative humidity 80% for temperatures up to 31°C decreasing linearly to 50% relative humidity at 40°C	
Pollution degree	Applicable POLLUTION DEGREE of the intended environment is 2 (in most cases).	
Weight	25kg	

Mechanical data

Nominal torque	450Nm	600Nm
Maximum torque	600Nm	1000Nm
Operating time (90°)	42s	65s
Angular range	90° (180°-270° on request)	
Duty cycle	50%	
Drive ISO5211	Star 36 (depth 41mm) • F10/F12 (depth F10 : 25mm / F12 : 30mm)	
Manual control	Secured hand wheel without clutching system	

Electrical data

Voltages ¹⁾	230 V AC (50/60 Hz) • 3-phase 400 V (50 Hz)	
Rated current	400 V: 0,45 A (cos φ = 0,8) • 230 V: 1,3 A (cos φ = 0,8)	
Overvoltage category ²⁾	TRANSIENT OVERVOLTAGES up to the levels of OVERVOLTAGE CATEGORY II	
Power	250W	
Torque limiter	Mechanical	
Number of feedback switches	2 (4 on request)	
Limit switches maximum voltage	4 to 250V AC/DC (Overvoltage category II)	
Limit switches maximum current	1mA to 5A max	
Anticondensation heaters	10W	

¹⁾ The actuator tolerates voltage fluctuation of the electrical grid up to $\pm 10\%$ of its nominal system operating voltage

²⁾ The actuator tolerates temporary overvoltage of the electrical grid