



aerospace
 climate control
 electromechanical
 filtration
 fluid & gas handling
 hydraulics
 pneumatics
 process control
 sealing & shielding



Interact Xpress

Touchscreen HMI with Integrated Webserver



ENGINEERING YOUR SUCCESS.

Autoryzowany dystrybutor Parker:

ARA
 PNEUMATIK

53-012 Wrocław tel. 71 364 72 82
 ul. Wyscigowa 38 fax 71 364 72 83

www.arapneumatik.pl





WARNING – USER RESPONSIBILITY

FAILURE OR IMPROPER SELECTION OR IMPROPER USE OF THE PRODUCTS DESCRIBED HEREIN OR RELATED ITEMS CAN CAUSE DEATH, PERSONAL INJURY AND PROPERTY DAMAGE.

- This document and other information from Parker-Hannifin Corporation, its subsidiaries and authorized distributors provide product or system options for further investigation by users having technical expertise.
- The user, through its own analysis and testing, is solely responsible for making the final selection of the system and components and assuring that all performance, endurance, maintenance, safety and warning requirements of the application are met. The user must analyze all aspects of the application, follow applicable industry standards, and follow the information concerning the product in the current product catalog and in any other materials provided from Parker or its subsidiaries or authorized distributors.
- To the extent that Parker or its subsidiaries or authorized distributors provide component or system options based upon data or specifications provided by the user, the user is responsible for determining that such data and specifications are suitable and sufficient for all applications and reasonably foreseeable uses of the components or systems.

Overview	5
Complete Transparency and Supervisory Control.....	6
HMI Power and Connectivity In a Durable, Affordable Package	8
Interact Xpress Features.....	8
Technical Characteristics.....	9
Technical Data	9
Environmental Characteristics	10
Standards and Conformance	10
Dimensions	10
Order Code.....	13
Interact Xpress	13
Accessories	13

Parker Hannifin

The global leader in motion and control technologies

A world class player on a local stage

Global Product Design

Parker Hannifin has more than 40 years experience in the design and manufacturing of drives, controls, motors and mechanical products. With dedicated global product development teams, Parker draws on industry-leading technological leadership and experience from engineering teams in Europe, North America and Asia.

Local Application Expertise

Parker has local engineering resources committed to adapting and applying our current products and technologies to best fit our customers' needs.

Manufacturing to Meet Our Customers' Needs

Parker is committed to meeting the increasing service demands that our customers require to succeed in the global industrial market. Parker's manufacturing teams seek continuous improvement through the implementation of lean manufacturing methods throughout the process. We measure ourselves on meeting our customers' expectations of quality and delivery, not just our own. In order to meet these expectations, Parker operates and continues to invest in our manufacturing facilities in Europe, North America and Asia.

Electromechanical Worldwide Manufacturing Locations

Europe

Littlehampton, United Kingdom
Dijon, France
Offenburg, Germany
Filderstadt, Germany
Milan, Italy

Asia

Wuxi, China
Chennai, India

North America

Rohnert Park, California
Irwin, Pennsylvania
Charlotte, North Carolina
New Ulm, Minnesota



Offenburg, Germany

Local Manufacturing and Support in Europe

Parker provides sales assistance and local technical support through a network of dedicated sales teams and authorized technical distributors throughout Europe.

For contact information, please refer to the Sales Offices on the back cover of this document or visit www.parker.com



Milan, Italy



Littlehampton, UK

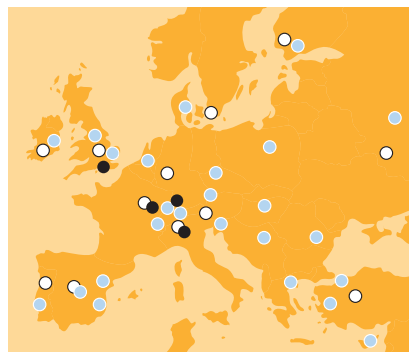

- Electromechanical Manufacturing
- Parker Sales Offices
- Distributors



Dijon, France

Touchscreen HMI with Integrated Webserver - Interact Xpress

Overview

Description

Distributed HMI in a durable and affordable package

XPR2 PowerStation line offers a hardware/software solution that simplifies and cost-reduces distributed HMI applications. Available with a 6", 8", 10", 15" TFT panel mount touchscreen or new non-display system. XPR2 models are designed to optimize the performance, storage and connectivity features of Interact Xpress™ HMI software.

This CE-based workstations features the latest embedded processor technology supporting fanless operation, CompactFlash® storage, USB, serial and 100Base-T Ethernet connectivity.

Take full advantage of the web for; HMI design, publishing, runtime and support

Interact Xpress fully leverages the wide availability of web browsing software to enable distributed HMI software, remote support and application sharing on the internet and IP networks. Interact Xpress HMI applications are developed, edited, published and run in an HMI that is a web server, allowing users and OEMs to easily publish upgrades and applications to any global location with an internet connection and a web browser.

Interact Xpress combines a rich, graphical runtime interface with HMI development tools that can be accessed from either the HMI panel or any PC running Internet Explorer®.

Features

- Fanless operation
- More than 40 communication drivers
- Complex animation capabilities
- Alarm logging
- Sending email on alarms
- Recipes
- Real time trending
- PDF documents viewing
- Multi language support
- Screen templates



Technical Characteristics - Overview

Display	262 144 color TFT
Storage options	512 MB CompactFlash
Operating system	Windows CE
Ports	<ul style="list-style-type: none">• 2 USB• RS232/422/485• 10/100 Base-T Ethernet
Power supply	24 VDC

Complete Transparency and Supervisory Control

Interact Xpress provides your system with a connection to the rest of the company or the rest of the world. It offers a completely web-published environment where any plant-floor data or information can be accessed from any web browser with an Ethernet connection to the XPR PowerStation on your machine.

- Reduces HMI development time by automatically sharing tags with the ACR9640 programmable automation controller
- Pre-built template screens for common functions reduce your time to market
- Integrated development environment allows applications to be designed and edited on the runtime system
- HMI designer/editor supports multiple runtime versions, eliminating version control management headaches
- Easy, object-based screen development using a "tool bin" of pre-configured panels tools and drag-and-drop editing
- Panel tools include pushbuttons, numeric entry, selection entry, numeric displays, bar graphs, meters, gauges, sliders, message displays, time/date display and more
- 3-D, shaded panel tool graphic are available in multiple styles with no additional work
- Includes an integrated graphics library
- Jpeg (.jpg) and Flash (.swf) image support
- Complex animation capabilities and video support
- Web link support
- Pre-configured alarm tool with automatic collection of historical alarm data
- Integrated tag editor with drag-and-drop tools and import/export to Excel and other software packages



- Development software for offline design/editing supports Windows® 2000 and Windows® XP operating systems
- Reduces SCADA development time by up to 80 %, when used with our InteractX SCADA
- Interact Xpress is offered in everything from a no-display system to a 15" integrated display size
- More than 40 bundled communications servers allow Xpress to work with everything from our ACR9640 Xpress to virtually any legacy equipment you may have

- Real time trend display capability: Up to 1000 point historical buffer Any tag or expression can be used for values
- Multi Language support: Support export applications Easily export an application and translate all text, using standard tools

Real-time trending with 1000-point buffer for each pen.



Windows® is a registered trademark of Microsoft Corporation.

Parker's Interact Xpress HMI with InteractX SCADA delivers your plant-floor data wherever it's needed, when it's needed.

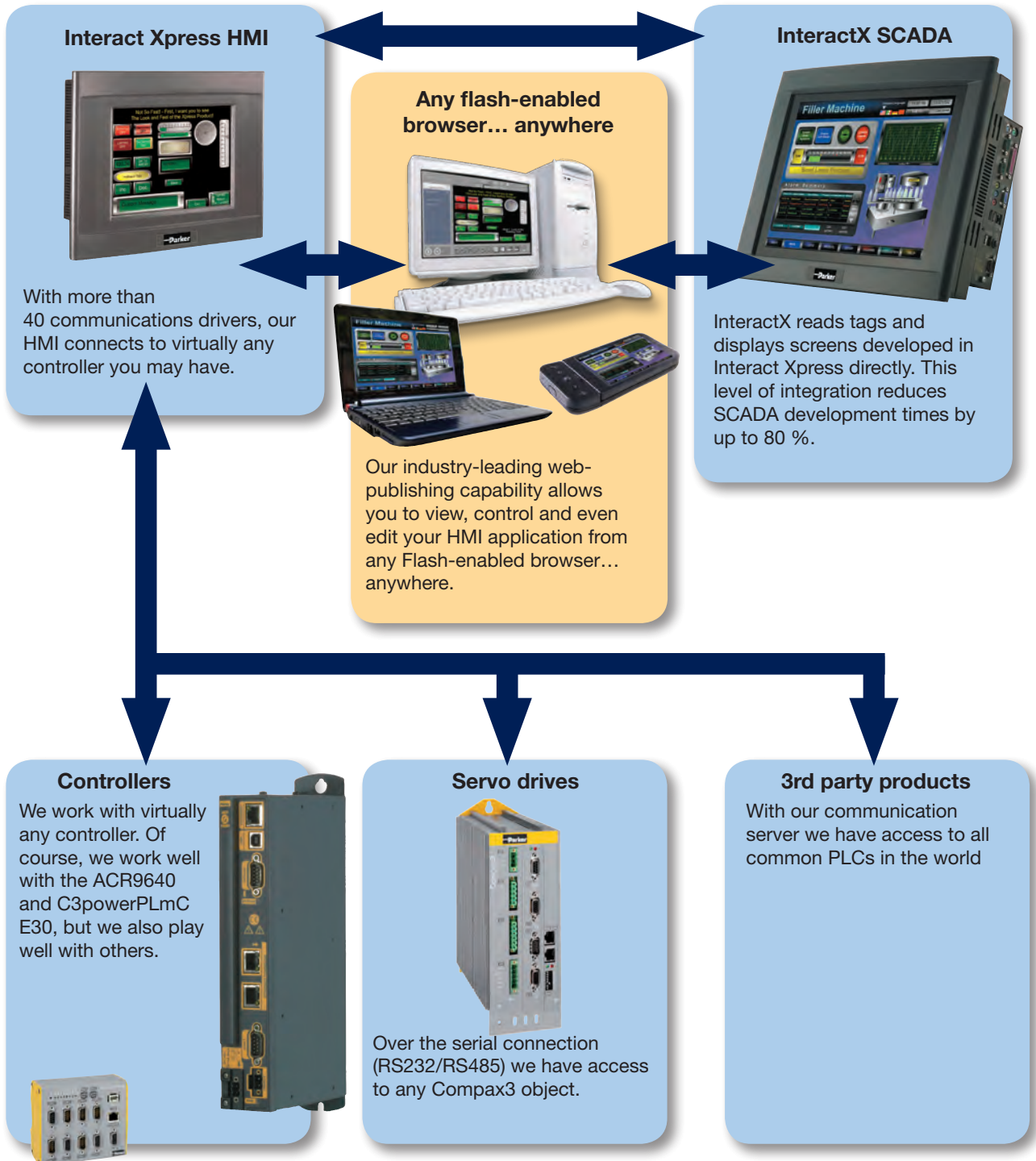

HMI Power and Connectivity In a Durable, Affordable Package

Interact Xpress software is pre-installed and bundled with XPR2 PowerStation hardware, which is designed to optimize the performance, storage and connectivity features of Xpress HMI. This CE-based workstation is available with 6", 8", 10" and 15" TFT touchscreen display models, embedded fanless CPU technology, 256 MB DRAM and a full range of standard features such as CompactFlash storage, 2 USB ports, 2 RS232 and RS232/422/485 ports and a 100Base-T Ethernet port.

With standard 512 MB CompactFlash storage, XPR2 models use non-rotating storage media for high system reliability. And like all PowerStations, these units are quality tested to endure more harsh conditions in a day than most operator stations see in a lifetime.

XPR2 PowerStations offer durability and no moving parts, to complement Xpress software in providing a high-value, Distributed HMI solution.



Interact Xpress Features

- Sophisticated graphics look and feel with ease of development
- Integrated Web Publishing capability for distributed applications
- Applications can be served, created and edited online from any PC with Internet Explorer
- Available offline, development software allows work on applications when a live Internet connection is not available
- Advanced security for single or multi-user applications
- Tools for historical alarm data
- Capacity for complex graphics and animations
- Standard Ethernet port for both networking and controller communications
- More than 40 device communication drivers
- Unlimited tags
- Color depth to 262 144 colors



Technical Characteristics

Technical Data

Model	XPR200	XPR206	XPR208	XPR210	XPR215
Display size	Remote unit No display	6" color TFT, 5.7" (145 mm) diagonal	8" color TFT, 8.0" (203mm) diagonal	10" color TFT, 10.4" (264mm) diagonal	15" color TFT, 15.0" (380mm) diagonal
Resolution	-	VGA (640x480), 262 144 color TFT	VGA (640x480), 262 144 color TFT	VGA (600x480)	XGA (1024x768), 262 144 color TFT
Luminance 1 NIT = 1 cd/m ²	-	350 NIT	400 NIT	200 NIT	250 NIT
Viewing angle	-	±80° L/R, 80° U, 70° D	+70 L/R, 60° U, 65° D	+70° L/R, 50° U, 60° D	+80° L/R, 80° U, 60° D
Backlight	-	75 000 h	50 000 h	50 000 h	40 000 h

Model	XPR200	XPR206	XPR208	XPR210	XPR215
Interface	Analog resistive touchscreen				
Operating system	Windows CE version 5.0				
Processor support					
Processor	AMD 500 MHz LX800 processor				
Cache	256 kB (L1/L2)				
Memory	256 MB DRAM				
Storage options					
CompactFlash	512 MB ¹⁾ CompactFlash external type II slot (IDE bootable)				
Floppy/CD ROM	External connection via USB				
Ports					
Keyboard	USB 2.0				
Mouse	USB 2.0				
USB	(2) USB 2.0 ports type-A, CD/floppy/USB drive bootable with over current protection				
Serial	(1) RS232 9-Pin D-sub (1) RS232/422/485 9-Pin D-sub				
Ethernet	(1) 10/100Base-T w/ RJ45				
Power requirement	24 VDC, 2 A maximum, optional AC adaptor				

¹⁾ Actual storage volumes may be higher

Environmental Characteristics

Ambient conditions

Temperature range	0...50 °C
Relative humidity	5...95 % (non-cond.)
Shock	10 g, 11 ms (operating) 30 g, 11 ms (non-operating)
Vibration	10...500 Hz, 2 grms (random-operational-CompactFlash)

Standards and Conformance

Agency approval	CE; UL/cUL
------------------------	------------

Dimensions

XPR200 mounting dimensions

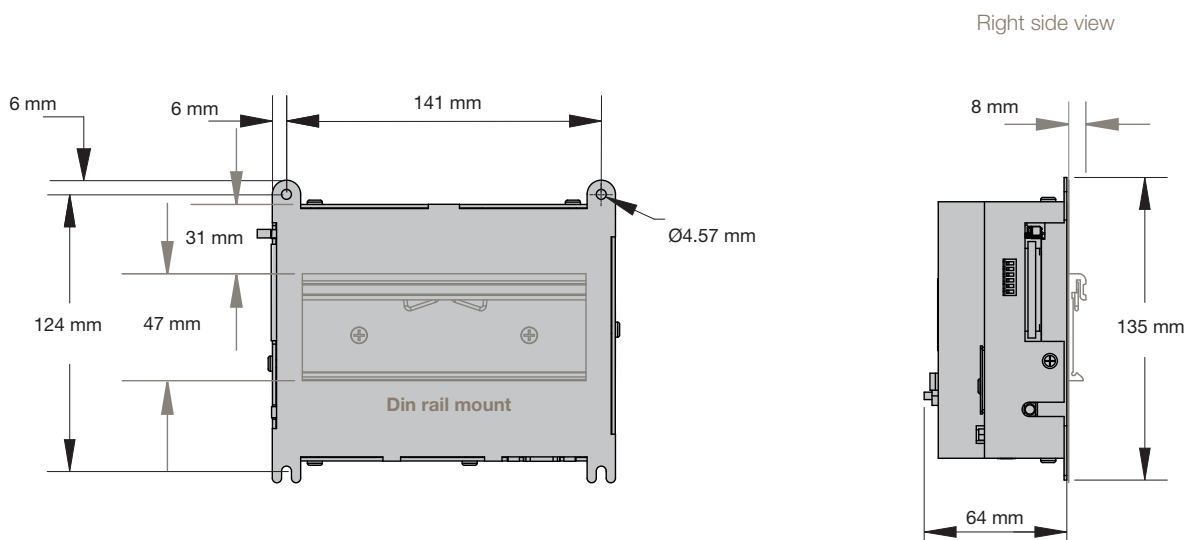

XPR206 cutout and mounting dimensions

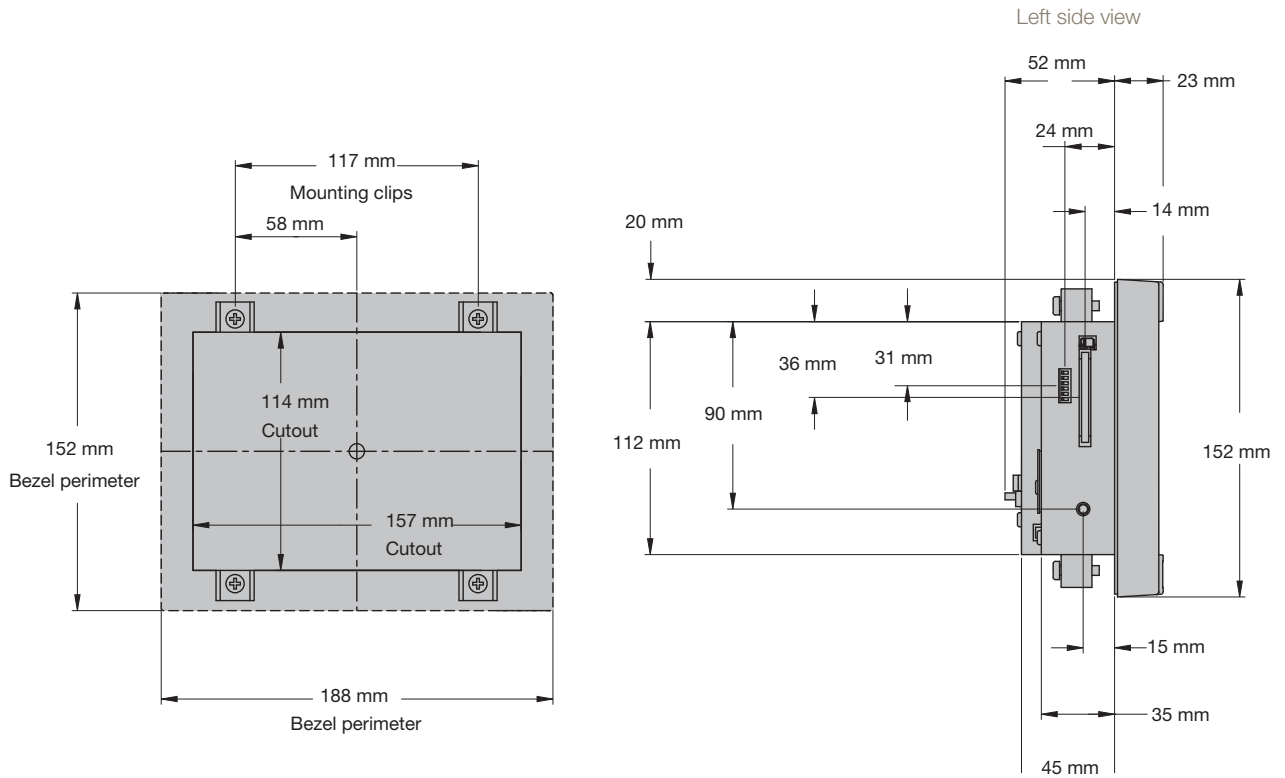

XPR208 cutout and mounting dimensions

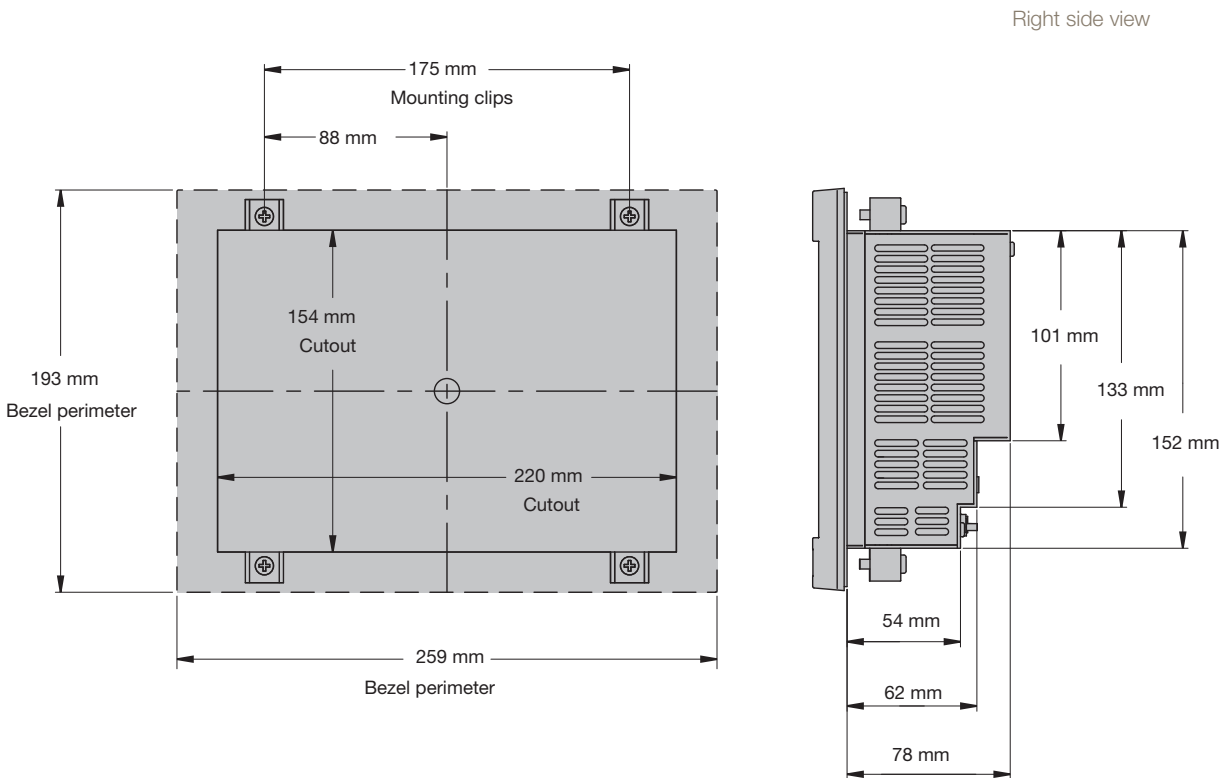

XPR210 cutout and mounting dimensions

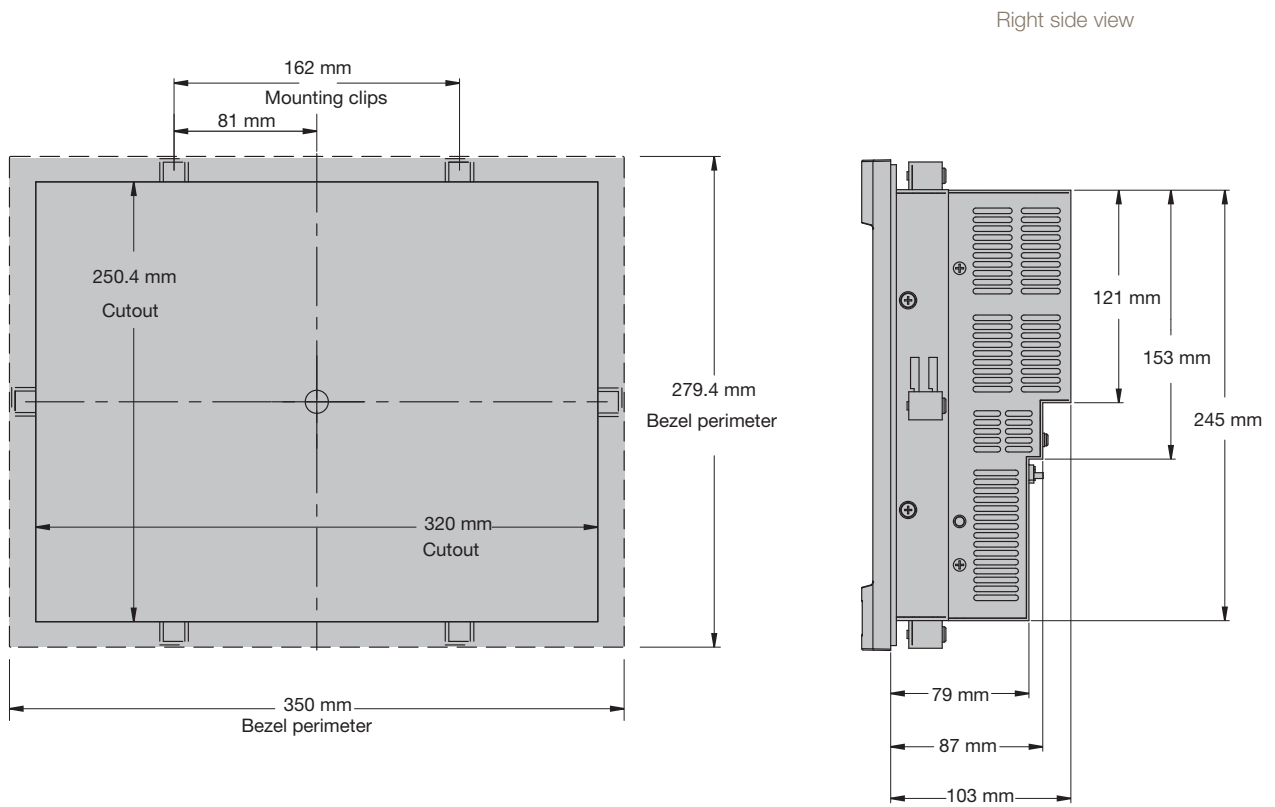

XPR215 cutout and mounting dimensions

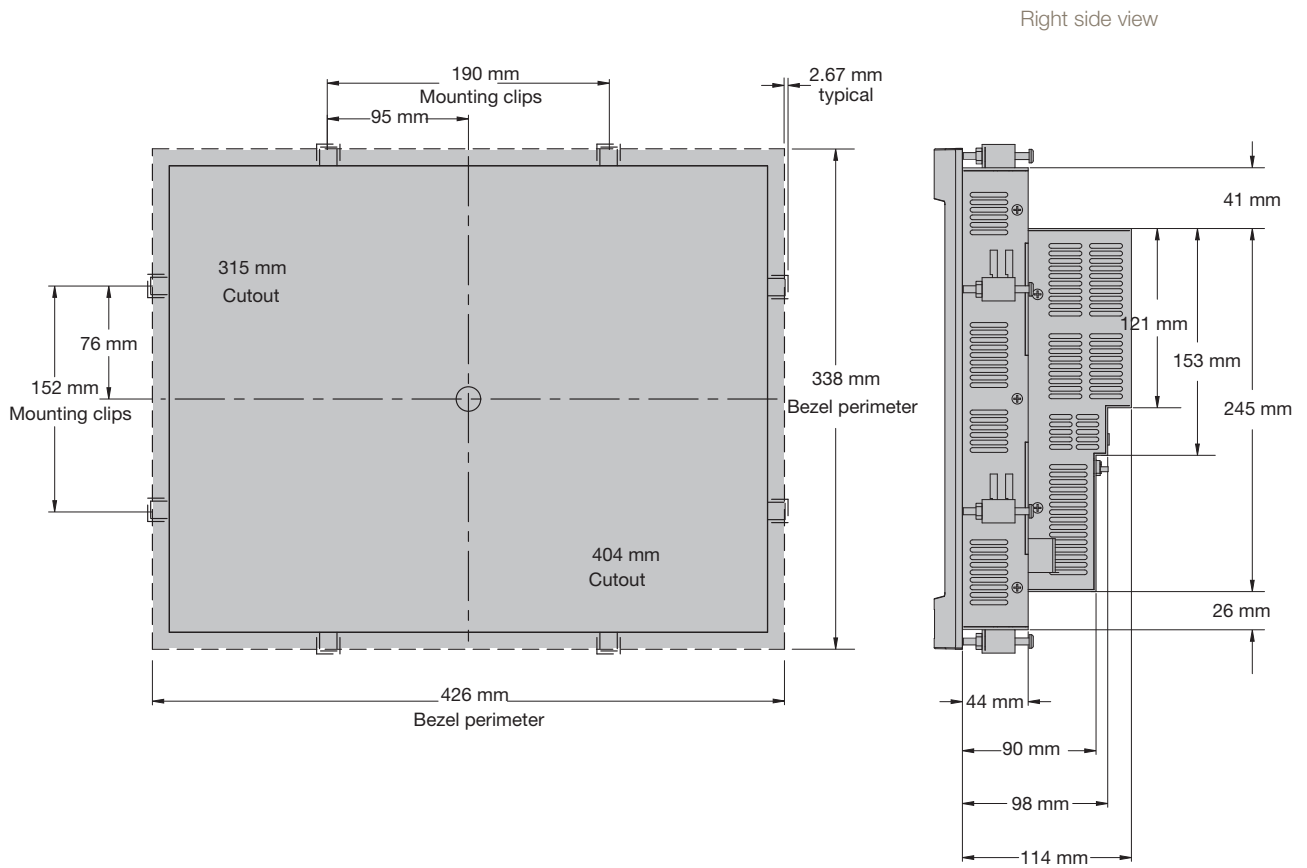

Order Code

Interact Xpress

	1	2		3	4	5
Order example	XPR2	10VT	-	2	P	3

1 Series	XPR2 Industrial PC
2 Display	00XN Non-display system
	06VT 6" color TFT VGA (640x480)
	08VT 8" color TFT VGA (640x480)
	10VT 10" color TFT VGA (640x480)
	15XT 15" color TFT XGA (1024x768)
	15AT 15" color TFT XGA (1024x768) Stainles Bezel

3 Processor	2 AMD LX800 500 MHz~
4 CompactFlash⁴⁾	P 512 MB FLASH
5 Agency approvals	3 UL/cUL/CE

Accessories

Software

	1
Order example	IXM-0200

1 Type number of accessory	IXM-0200 Xpress Manager, Offline Development Software
-----------------------------------	--

Cables

	1		2
Order example	SSK01	/	01

1 Type number of accessory	SSK01/xx RS232 cable XPR to Compax3 ¹⁾
	SSK28/xx RJ45 Ethernet crossover cable ²⁾

Length code for cables

¹⁾ Length code 1 (Example: SSK01/09 = length 25 m)

Length [m]	1.0	2.5	5.0	7.5	10.0	12.5	15.0	20.0	25.0	30.0	35.0	40.0	45.0	50.0
Order code	01	02	03	04	05	06	07	08	09	10	11	12	13	14

²⁾ Length code 2 for SSK28

Length [m]	0.17	0.25	0.5	1.0	3.0	5.0	10.0
Order code	23	20	21	01	22	03	05

Parker's Motion & Control Technologies

At Parker, we're guided by a relentless drive to help our customers become more productive and achieve higher levels of profitability by engineering the best systems for their requirements. It means looking at customer applications from many angles to find new ways to create value. Whatever the motion and control technology need, Parker has the experience, breadth of product and global reach to consistently deliver. No company knows more about motion and control technology than Parker. For further info call 00800 27 27 5374.



AEROSPACE

Key Markets

- Aircraft engines
- Business & general aviation
- Commercial transports
- Land-based weapons systems
- Military aircraft
- Missiles & launch vehicles
- Regional transports
- Unmanned aerial vehicles

Key Products

- Flight control systems & components
- Fluid conveyance systems
- Fluid metering delivery & atomization devices
- Fuel systems & components
- Hydraulic systems & components
- Inert nitrogen generating systems
- Pneumatic systems & components
- Wheels & brakes



CLIMATE CONTROL

Key Markets

- Agriculture
- Air conditioning
- Food, beverage & dairy
- Life sciences & medical
- Precision cooling
- Processing
- Transportation

Key Products

- CO² controls
- Electronic controllers
- Filter driers
- Hand shut-off valves
- Hose & fittings
- Pressure regulating valves
- Refrigerant distributors
- Safety relief valves
- Solenoid valves
- Thermostatic expansion valves



ELECTROMECHANICAL

Key Markets

- Aerospace
- Factory automation
- Food & beverage
- Life science & medical
- Machine tools
- Packaging machinery
- Paper machinery
- Plastics machinery & converting
- Primary metals
- Semiconductor & electronics
- Textile
- Wire & cable

Key Products

- AC/DC drives & systems
- Electric actuators
- Controllers
- Gantry robots
- Gearheads
- Human machine interfaces
- Industrial PCs
- Inverters
- Linear motors, slides and stages
- Precision stages
- Stepper motors
- Servo motors, drives & controls
- Structural extrusions



FILTRATION

Key Markets

- Food & beverage
- Industrial machinery
- Life sciences
- Marine
- Mobile equipment
- Oil & gas
- Power generation
- Process
- Transportation

Key Products

- Analytical gas generators
- Compressed air & gas filters
- Condition monitoring
- Engine air, fuel & oil filtration & systems
- Hydraulic, lubrication & coolant filters
- Process, chemical, water & microfiltration filters
- Nitrogen, hydrogen & zero air generators



FLUID & GAS HANDLING

Key Markets

- Aerospace
- Agriculture
- Bulk chemical handling
- Construction machinery
- Food & beverage
- Fuel & gas delivery
- Industrial machinery
- Mobile
- Oil & gas
- Transportation
- Welding

Key Products

- Brass fittings & valves
- Diagnostic equipment
- Fluid conveyance systems
- Industrial hose
- PTFE & PFA hose, tubing & plastic fittings
- Rubber & thermoplastic hose & couplings
- Tube fittings & adapters
- Quick disconnects



HYDRAULICS

Key Markets

- Aerospace
- Aerial lift
- Agriculture
- Construction machinery
- Forestry
- Industrial machinery
- Mining
- Oil & gas
- Power generation & energy
- Truck hydraulics

Key Products

- Diagnostic equipment
- Hydraulic cylinders & accumulators
- Hydraulic motors & pumps
- Hydraulic systems
- Hydraulic valves & controls
- Power take-offs
- Rubber & thermoplastic hose & couplings
- Tube fittings & adapters
- Quick disconnects



PNEUMATICS

Key Markets

- Aerospace
- Conveyor & material handling
- Factory automation
- Food & beverage
- Life science & medical
- Machine tools
- Packaging machinery
- Transportation & automotive

Key Products

- Air preparation
- Compact cylinders
- Field bus valve systems
- Grippers
- Guided cylinders
- Manifolds
- Miniature fluidics
- Pneumatic accessories
- Pneumatic actuators & grippers
- Pneumatic valves and controls
- Rodless cylinders
- Rotary actuators
- Tie rod cylinders
- Vacuum generators, cups & sensors



PROCESS CONTROL

Key Markets

- Chemical & refining
- Food, beverage & dairy
- Medical & dental
- Microelectronics
- Oil & gas
- Power generation

Key Products

- Analytical sample conditioning products & systems
- Fluoropolymer chemical delivery fittings, valves & pumps
- High purity gas delivery fittings, valves & regulators
- Instrumentation fittings, valves & regulators
- Medium pressure fittings & valves
- Process control manifolds



SEALING & SHIELDING

Key Markets

- Aerospace
- Chemical processing
- Consumer
- Energy, oil & gas
- Fluid power
- General industrial
- Information technology
- Life sciences
- Military
- Semiconductor
- Telecommunications
- Transportation

Key Products

- Dynamic seals
- Elastomeric o-rings
- EMI shielding
- Extruded & precision-cut, fabricated elastomeric seals
- Homogeneous & inserted elastomeric shapes
- High temperature metal seals
- Metal & plastic retained composite seals
- Thermal management

Parker Worldwide

Europe, Middle East, Africa

AE – United Arab Emirates, Dubai
Tel: +971 4 8127100
parker.me@parker.com

AT – Austria, Wiener Neustadt
Tel: +43 (0)2622 23501-0
parker.austria@parker.com

AT – Eastern Europe, Wiener Neustadt
Tel: +43 (0)2622 23501 900
parker.easteurope@parker.com

AZ – Azerbaijan, Baku
Tel: +994 50 2233 458
parker.azerbaijan@parker.com

BE/LU – Belgium, Nivelles
Tel: +32 (0)67 280 900
parker.belgium@parker.com

BY – Belarus, Minsk
Tel: +375 17 209 9399
parker.belarus@parker.com

CH – Switzerland, Etoy
Tel: +41 (0)21 821 87 00
parker.switzerland@parker.com

CZ – Czech Republic, Klecany
Tel: +420 284 083 111
parker.czechrepublic@parker.com

DE – Germany, Kaarst
Tel: +49 (0)2131 4016 0
parker.germany@parker.com

DK – Denmark, Ballerup
Tel: +45 43 56 04 00
parker.denmark@parker.com

ES – Spain, Madrid
Tel: +34 902 330 001
parker.spain@parker.com

FI – Finland, Vantaa
Tel: +358 (0)20 753 2500
parker.finland@parker.com

FR – France, Contamine s/Arve
Tel: +33 (0)4 50 25 80 25
parker.france@parker.com

GR – Greece, Athens
Tel: +30 210 933 6450
parker.greece@parker.com

HU – Hungary, Budaörs
Tel: +36 23 885 470
parker.hungary@parker.com

IE – Ireland, Dublin
Tel: +353 (0)1 466 6370
parker.ireland@parker.com

IT – Italy, Corsico (MI)
Tel: +39 02 45 19 21
parker.italy@parker.com

KZ – Kazakhstan, Almaty
Tel: +7 7273 561 000
parker.easteurope@parker.com

NL – The Netherlands, Oldenzaal
Tel: +31 (0)541 585 000
parker.nl@parker.com

NO – Norway, Asker
Tel: +47 66 75 34 00
parker.norway@parker.com

PL – Poland, Warsaw
Tel: +48 (0)22 573 24 00
parker.poland@parker.com

PT – Portugal, Leca da Palmeira
Tel: +351 22 999 7360
parker.portugal@parker.com

RO – Romania, Bucharest
Tel: +40 21 252 1382
parker.romania@parker.com

RU – Russia, Moscow
Tel: +7 495 645-2156
parker.russia@parker.com

SE – Sweden, Spånga
Tel: +46 (0)8 59 79 50 00
parker.sweden@parker.com

SK – Slovakia, Banská Bystrica
Tel: +421 484 162 252
parker.slovakia@parker.com

SL – Slovenia, Novo Mesto
Tel: +386 7 337 6650
parker.slovenia@parker.com

TR – Turkey, Istanbul
Tel: +90 216 4997081
parker.turkey@parker.com

UA – Ukraine, Kiev
Tel: +380 44 494 2731
parker.ukraine@parker.com

UK – United Kingdom, Warwick
Tel: +44 (0)1926 317 878
parker.uk@parker.com

ZA – South Africa, Kempton Park
Tel: +27 (0)11 961 0700
parker.southafrica@parker.com

North America

CA – Canada, Milton, Ontario
Tel: +1 905 693 3000

US – USA, Cleveland
Tel: +1 216 896 3000

Asia Pacific

AU – Australia, Castle Hill
Tel: +61 (0)2-9634 7777

CN – China, Shanghai
Tel: +86 21 2899 5000

HK – Hong Kong
Tel: +852 2428 8008

IN – India, Mumbai
Tel: +91 22 6513 7081-85

JP – Japan, Tokyo
Tel: +81 (0)3 6408 3901

KR – South Korea, Seoul
Tel: +82 2 559 0400

MY – Malaysia, Shah Alam
Tel: +60 3 7849 0800

NZ – New Zealand, Mt Wellington
Tel: +64 9 574 1744

SG – Singapore
Tel: +65 6887 6300

TH – Thailand, Bangkok
Tel: +662 186 7000-99

TW – Taiwan, Taipei
Tel: +886 2 2298 8987

South America

AR – Argentina, Buenos Aires
Tel: +54 3327 44 4129

BR – Brazil, Sao Jose dos Campos
Tel: +55 800 727 5374

CL – Chile, Santiago
Tel: +56 2 623 1216

MX – Mexico, Apodaca
Tel: +52 81 8156 6000

192-081015N3

December 2012

We reserve the right to make technical changes. The data correspond to the technical state at the time of printing.
© 2012 Parker Hannifin Corporation.
All rights reserved.



EMEA Product Information Centre

Free phone: 00 800 27 27 5374

(from AT, BE, CH, CZ, DE, DK, EE, ES, FI, FR, IE, IL, IS, IT, LU, MT, NL, NO, PL, PT, RU, SE, SK, UK, ZA)

US Product Information Centre

Toll-free number: 1-800-27 27 537

www.parker.com

Autoryzowany dystrybutor Parker:

ARA
PNEUMATIK

53-012 Wrocław tel. 71 364 72 82
ul. Wyciągowa 38 fax 71 364 72 83

www.arapneumatik.pl

