

Contents

Description	Page
Check valves	4-5
Quick exhaust valves	6
In-line throttle check valves	7-9
Screw-in throttle check valves	10-21

Check valves

- *Check valves*
- *Quick exhaust valves*
- *In-line throttle check valves,*
- *Screw-in throttle check valves*

Metal version
Plastic version



ARA[®]
PNEUMATIK
53-012 Wrocław tel. 71 364 72 82
ul. Wyścigowa 38 fax 71 364 72 83
www.arapneumatik.pl



Check valves G1/8, G1/4

In-line version

Series RV

RV series check valves are designed for continuous flow (not suitable for pulsating flow).



Characteristics			Pressures quoted as gauge pressure	
Characteristics	Symbol	Unit	Description	
General features				
Type			Spring loaded check valve	
Mounting			Directly in tubing	
Tube connection			Thread	
Port size			G1/8	G1/4
Weight (mass)		kg	0.02	0.02
Installation				
In any position				
Ambient temperature range	T_{min}	°C	-20	Note: When using below freezing point (0 °C) it is necessary to consult us
	T_{max}	°C	+80	
Medium temperature range	T_{min}	°C	0	
	T_{max}	°C	+80	
Medium			Filtered compressed air, gases, fluids	
Lubrication			Oil mist lubrication compatible with Buna N	
Pneumatic characteristics				
Nominal pressure	p_n	bar	6	
Operating pressure range	p_{min}	bar	0.5	
	p_{max}	bar	10	
Nominal flow	Q_N	l/min	700	1000
Flow direction			In one direction	
Differential pressure for opening the check valve		bar	< 0.5	

Dimensions

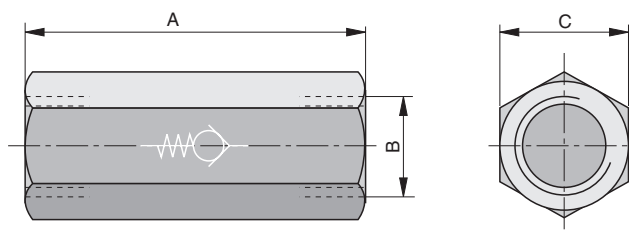

Dimension table and order instructions

Order Instructions		Dimension		
Type	Order No.	A	B	C
RV-06	PA10024	40	G1/8	SW17
RV-08	PA12007	45	G1/4	SW17

Dimensions in mm



Check valves G3/8 – G11/2

In-line version

Series RV9

RV9 series check valves are designed for continuous flow (not suitable for pulsating flow).

Suitable for:
– 100% oxygen
– natural gas
– vacuum



Characteristics			Pressures quoted as gauge pressure					
Characteristics	Symbol	Unit	Description					
General features								
Type	Spring loaded check valve							
Mounting	Directly in tubing							
Tube connection	Thread							
Port size			G3/8	G1/2	G3/4	G1	G11/4	G11/2
Weight (mass)	kg		0.18	0.19	0.27	0.49	0.74	0.98
Installation	In any position							
Ambient and Medium temperature range	T_{min}	°C	-20		0	-20		
	T_{max}	°C	+110		+90°	+60		
			air		water	gas		
	Note: When using below freezing point (0 °C) it is necessary to consult us							
Medium	Filtered compressed air, cold and warm water, various oils							
Lubrication	Oil mist lubrication compatible with Buna N							
Material	Housing: brass Valve head: stainless steel Seal: synthetic rubber							
Pneumatic characteristics								
Operating pressure range at +20°C	p_{max}	bar	25	25	25	25	18	18
Flow direction	In one direction							

Dimensions

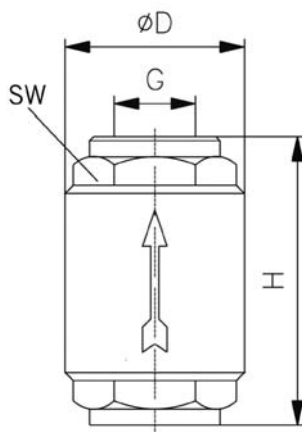

Dimension table and order instructions

Order Instructions		G	ØD	H	SW
Type *	Order No.				
RV9-10	PD 36114	G3/8	34.5	54	23
RV9-15	PD 36335	G1/2	34.5	57	27
RV9-20	PD 36336	G3/4	41.5	64	33
RV9-25	PD 36337	G1	48.0	75	40
RV9-32	PD 36338	G11/4	60.5	82	50
RV9-40	PD 36339	G11/2	71.0	93	55

* other sizes on request



Dimensions in mm

Quick exhaust valves G1/8 – G3/4

In-line version

Series SV

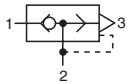

Characteristics			Pressures quoted as gauge pressure					
Characteristics	Symbol	Unit	Description					
General features								
Type	Poppet valve							
Mounting	Directly in tubing							
Tube connection	Thread							
Port size	G1/8 G1/4 G3/8 G1/2 G3/4							
Gewicht (Masse)	kg	0.086	0.147	0.150	0.314	0.450		
Installation								
In any position								
Ambient- and Medium temperature range	T_{min}	°C	-18	Note:				When using below freezing point (0 °C) it is necessary to consult us
	T_{max}	°C	+70					
Material								
– Housing Brass nickel-plated								
– Membrane Synthetic material								
Medium Filtered compressed air								
Lubrication Oil mist lubrication compatible with Buna N								
Pneumatische characteristics								
Nominal pressure	p_n	bar	6					
Operating pressure range	p_{min}	bar	0.3					
	p_{max}	bar	10					
Nominal flow 1→2	Q_N	l/min	680	1200	2300	3400	3200	
Nominal flow 2→3	Q_N	l/min	1100	2100	4900	6100	8750	

Dimensions

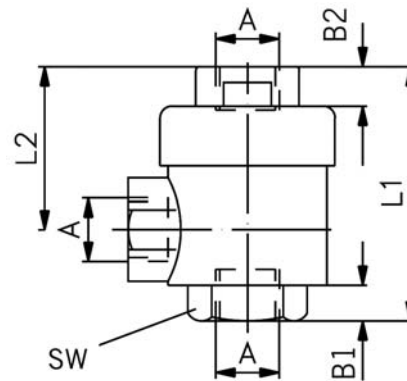

Dimension table and order instructions

Order Instructions		A	B1	B2	L1	L2	SW
Type	Order No.						
SV-06-2	PD39152	G1/8	6.5	6.5	42.0	27	15
SV-08-2	PD39153	G1/4	9.5	9.0	53.0	35	19
SV-10-2	PD39154	G3/8	9.5	9.5	55.5	36	21
SV-15-2	PD39155	G1/2	13.5	13.0	72.0	43	26
SV-20-2	PD39156	G3/4	18.0	18.0	88.0	55	32



Dimensions in mm

Throttle check valves M5 – G1/2

In-line version

Series DRV



Important:
Please note the flow direction
1 → 2 throttled
2 → 1 free exhaust

Characteristics		Pressures quoted as gauge pressure					
Characteristics	Symbol	Unit	Description				
General features							
Type	Throttle valve with parallelcheck valve						
Mounting	Directly in tubing, 2 through-bolts panel mounting						
Tube connection	Thread						
Port size			M5	G1/8	G1/4	G3/8	G1/2
Weight (mass)	kg		0.022	0.036	0.132	0.225	0.240
Installation	In any position						
Ambient temperature range	T_{min}	°C	-20	Note: When using below freezing point (0 °C) it is necessary to consult us			
	T_{max}	°C	+80				
Medium temperature range	T_{min}	°C	0				
	T_{max}	°C	+80				
Medium	Filtered compressed air, lubricated or unlubricated						
Lubrication	Oil mist lubrication compatible with Buna N						
Pneumatic characteristics							
Nominal pressure	p_n	bar	6				
Operating pressure range	p_{min}	bar	0.5				
	p_{max}	bar	10				
Nominal flow ¹⁾ (Throttle valve)	Q_N	l/min	80	125	450	1100	1200
Nominal flow ²⁾ (Check valve)	Q_N	l/min	80	125	450	1100	1200
Differential pressure for opening the check valve		bar	<0.5				

¹⁾ If the throttle is completely open
²⁾ If the throttle is completely closed

Flow characteristics
Type: DRV-M5

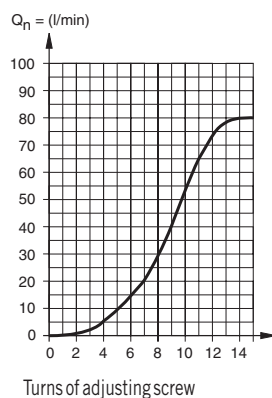

Dimensions in mm

Flow characteristics
Type: DRV-1/8

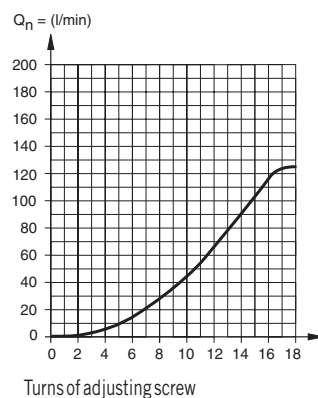

Flow characteristics
Type: DRV-1/4

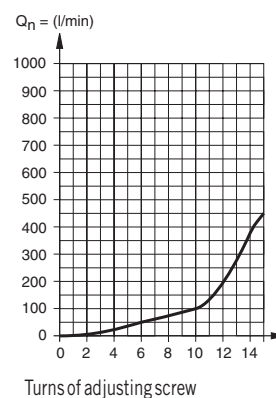

Throttle check valves M5 – G1/2

In-line version

Series DRV



Important:

Please note the flow direction

1 → 2 throttled

2 → 1 free exhaust

Dimensions

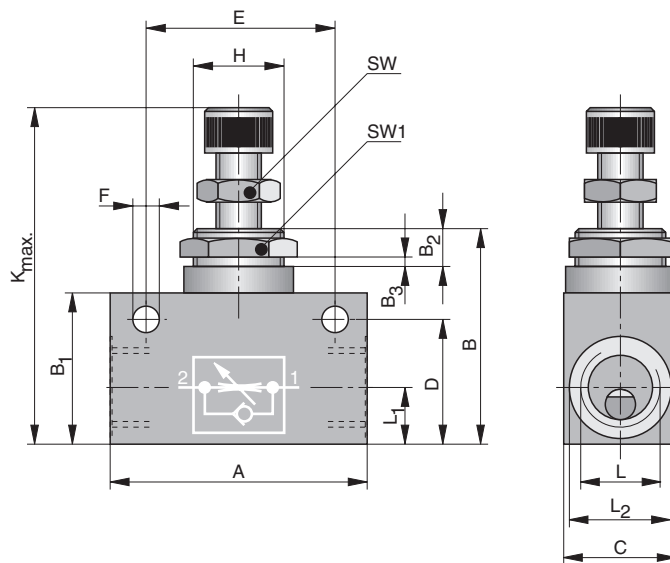

Dimension table and order instructions

Order Instructions	A	B	B ₁	B ₂	B ₃	C	D	E	ØF	H	L	L ₁	ØL ₂	K _{max}	SW	SW ₁
Type Order No.																
DRV-M5 PA 10232	26.0	26.5	16	6	2.5	14	12.5	18	4.4	M10x1	M5	5.5	8.5	44	7	14
DRV-1/8 PA 10233	32.5	31.5	22	6	2.5	16	17.5	24	4.4	M12x1	G1/8	9.0	13.5	52	10	17
DRV-1/4 PA 12594	55.0	48.0	32	10	4.5	25	25.0	35	6.5	M20x1.5	G1/4	12.0	19.0	72	13	22
DRV-3/8 PA 16143	58.0	57.0	40	10	5.0	30	33.0	43	6.5	M24x1.5	G3/8	13.5	23.0	92	19	27
DRV-1/2 PA 16144	68.0	57.0	40	10	5.0	30	33.0	50	6.5	M24x1.5	G1/2	15.0	27.5	92	19	27

Dimensions in mm

Flow characteristics
Type: DRV-3/8

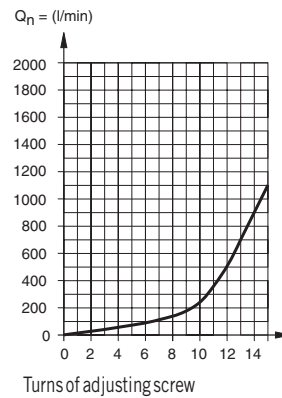

Flow characteristics
Type: DRV-1/2

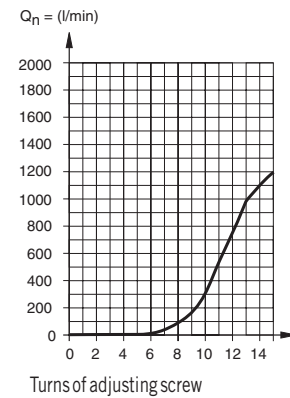

Characteristics		Pressures quoted as gauge pressure					
Characteristics	Symbol	Unit	Description				
General features							
Tube connection		Push-in connections					
Tube diameter	ØOD	mm	4	6	8	10	12
Installation		In any position					
Ambient- and Medium temperature range	T_{min}	°C	-20	Note: When using below freezing point (0 °C) it is necessary to consult us			
	T_{max}	°C	+60				
Material		Housing – aluminium/plastic Throttle spindle – brass, anodized Seals – Buna N					
Pneumatische characteristics							
Nominal pressure	p_n	bar	6				
Operating pressure range	p_{min}	bar	0				
	p_{max}	bar	10				
Nominal flow ¹⁾ (Throttle valve)	Q_N	l/min	117	183	300	467	767
Nominal flow ²⁾ (Check valve)	Q_N	l/min	234	366	600	934	1534

1) If the throttle is completely open
2) If the throttle is completely closed

Throttle check valves, plastic, with push-in connections

In-line

Series DRV

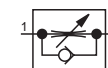

Important:
Please note the flow direction
1 → 2 throttled
2 → 1 free exhaust

Dimensions

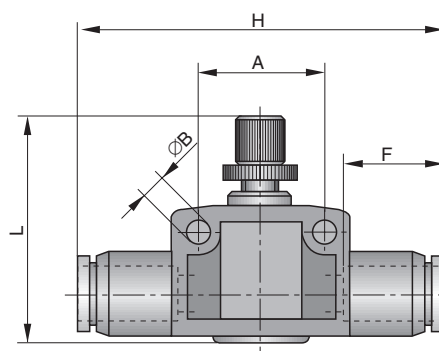

Dimension table and order instructions

Order Instructions		Tube	L_{max}	A	ØB	F	H
Type	Order No.	ØOD					
DRV-4MsvKU	KT0447	4	29.9	15	3.3	16.8	45.1
DRV-6MsvKU	KT0448	6	35.0	20	4.3	17.6	50.3
DRV-8MsvKU	KT0449	8	37.4	23	4.4	18.7	55.7
DRV-10MsvKU	KT0450	10	43.8	28	4.4	19.6	61.2
DRV-12MsvKU	KT0451	12	47.4	32	4.4	21.9	69.8

Dimensions in mm

ARA[®]
PNEUMATIK

53-012 Wrocław tel. 71 364 72 82
ul. Wyścigowa 38 fax 71 364 72 83

www.arapneumatik.pl



Screw-in check valves G1/8 – G1/2

Screw-in version

Series DRV

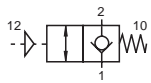

Actuation:
pneumatic deblocking

Characteristics			Pressures quoted as gauge pressure	
Characteristics	Symbol	Unit	Description	
Type			Spring loaded check valve with cone-shaped seal element and elastic seal	
Tube connection			Port 1: internal thread to ISO 228, push-in fitting Port 2: external thread to ISO 228 Port 12: M5, G1/8 internal	
Port size			See dimension table	
Installation			In any position – rings can be rotated 360° after the valve has been installed	
Ambient temperature range	T_{min} T_{max}	°C	-10 +60	Note: When using below freezing point (0 °C) it is necessary to consult us
Medium temperature range	T_{min} T_{max}	°C	-10 +60	
Medium			Filtered compressed air, neutral gases *	
Lubrication			With or without oil mist lubrication ¹⁾	
Material			Metal parts: nickel-plated brass or stainless steel Springs: stainless steel Seals: Buna N Sealing ring: Polyamide	
Pneumatic characteristics				
Nominal pressure	p_n	bar	6	
Operating pressure range	p_{min}	bar	0.3	
	p_{max}	bar	10	
Nominal flow	Q_N	l/min	See table	
Actuation				
pneumatic			Direct	
Actuation pressure range	p_{st}	bar	See diagram	

* other media on request

¹⁾ We recommend the use of mineral oil type VG32 to ISO 3448

Nominal flow, tightening torque, opening pressure, weight (mass)

Port size	DN [mm]	$Q_N 1 \rightarrow 2$ [l/min]	$Q_N 2 \rightarrow 1$ [l/min]	Max. tightening torque [Nm]	$p_{min 2 \rightarrow 1}$ [bar]	Weight mass [kg]
G1/8	3.0	220	280	1.2	0.2	0.068 – no hollow screw 0.048 – with thread G1/8 0.048 – fitting \varnothing 6
G1/4	4.4	340	460	1.8	0.2	0.050 – no hollow screw 0.075 – with thread G1/4 0.075 – fitting \varnothing 6 0.082 – fitting \varnothing 8
G3/8	5.7	700	910	3.5	0.2	0.150 – with thread G3/8 0.145 – fitting \varnothing 8 0.155 – fitting \varnothing 10
G1/2	8.8	1450	1660	4.0	0.15	0.210 – with thread G1/2 0.240 – fitting \varnothing 12



Dimensions in mm

Pilot pressure in relation to operating pressure

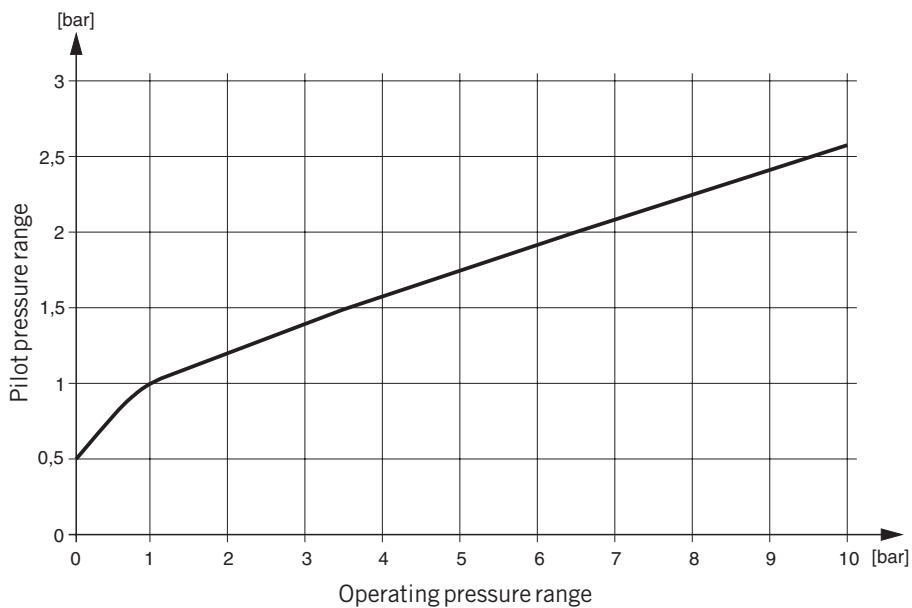

**Screw-in
check valves
G1/8 – G1/2**

Screw-in version

Series DRV

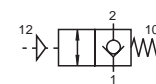

Actuation:
pneumatic deblocking

Example of Control System

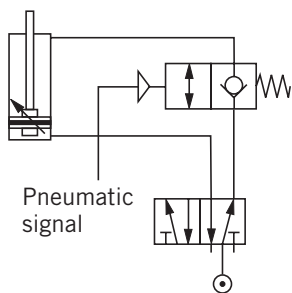

Example of Control System with Vertical Load

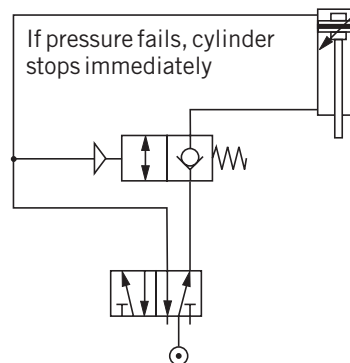

Dimensions in mm



Screw-in check valves G1/8 – G1/2

Dimensions

Version with internal thread

Version with push-in fitting

Screw-in version

Series ERV

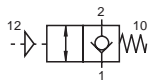

Betätigung:
pneumatisch entsperbar

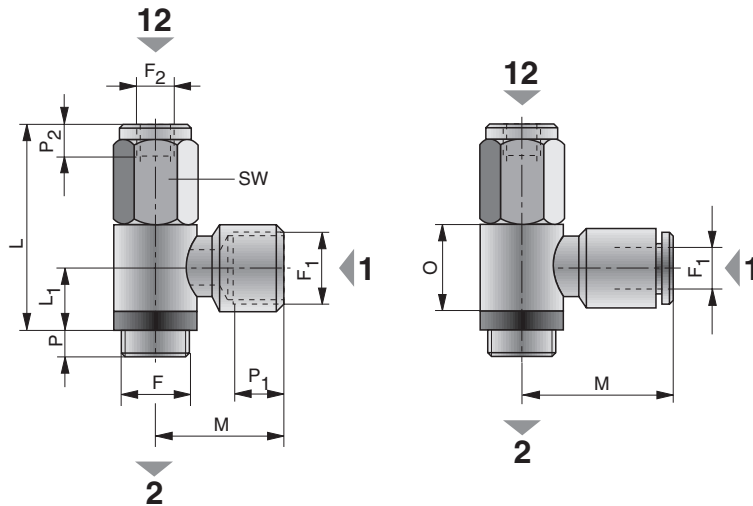

Dimension table and order instructions

Order Instructions		F	F ₁	F ₂	L	L ₁	M	O	P	P ₁	P ₂	SW
Type	Order No.											
ERV-1/8	KL4077	G1/8	G1/8	M5	37.5	12.5	21.0	15	6.5	7	6	14
ERV-1/8	KL4078	G1/8	∅ 6	M5	37.5	12.5	25.0	15	6.5	–	6	14
ERV-1/4	KL4080	G1/4	G1/4	G1/8	42.5	13.5	25.0	17	7.0	8	7	17
ERV-1/4	KL4081	G1/4	∅ 6	G1/8	42.5	13.5	27.5	17	7.0	–	7	17
ERV-1/4	KL4082	G1/4	∅ 8	G1/8	42.5	13.5	32.0	17	7.0	–	7	17
ERV-3/8	KL4083	G3/8	G3/8	G1/8	46.0	15.0	31.0	20	9.0	10	7	19
ERV-3/8	KL4084	G3/8	∅ 8	G1/8	46.0	15.0	31.5	20	9.0	–	7	19
ERV-3/8	KL4085	G3/8	∅ 10	G1/8	46.0	15.0	36.0	20	9.0	–	7	19
ERV-1/2	KL4086	G1/2	G1/2	G1/8	51.5	17.0	40.0	24	10.0	14	7	24
ERV-1/2	KL4087	G1/2	∅ 12	G1/8	51.5	17.0	40.5	24	10.0	–	7	24



Dimensions in mm

Screw-in throttle check valves G1/8, G1/4

Screw-in version

Series EDRV

for air outlet throttling



Speed regulating valve

This valve is used for regulating the piston speed of pneumatic cylinders.

Characteristics				Pressures quoted as gauge pressure	
Characteristics	Symbol	Unit	Description		
General features					
Type	Spring loaded throttle check valve				
Mounting	Screw-in valve				
Tube connection	Thread				
Port size			G1/8	G1/4	
Weight (mass)		kg	0.03	0.04	
Installation	In any position				
Ambient temperature range	T_{min} T_{max}	°C	-10	Note: When using below freezing point (0 °C) it is necessary to consult us	
		°C	+60		
Medium temperature range	T_{min} T_{max}	°C	-10		
		°C	+60		
Medium	Filtered compressed air				
Lubrication	Oil mist lubrication compatible with Buna N				
Pneumatic characteristics					
Nominal pressure	p_n	bar	6		
Operating pressure range	p_{min}	bar	0.5		
	p_{max}	bar	10		
Nominal flow throttle valve (throttle completely open)	Q_N	l/min	250	400	
Nominal flow check valve (throttle completely closed)	Q_N	l/min	350	450	

Dimensions

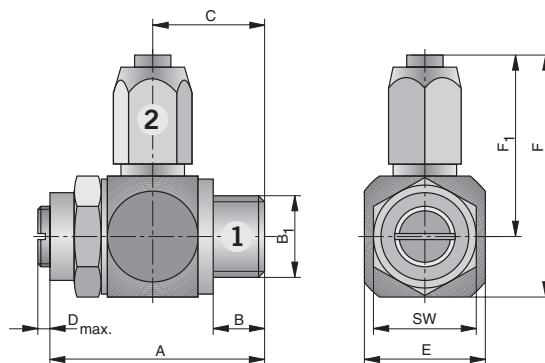

Dimension table and order instructions

Order Instructionsn		Tube	A	B	B ₁	C	D _{max}	E	F	F ₁	SW
Type	Order No.	ØOD/ID									
EDRV-06-5/3	PA 10018	5/3	34	8.0	G1/8	16.5	1.0	16	18.5	26.5	14
EDRV-06-6/4	PA 10019	6/4	34	8.0	G1/8	16.5	1.0	16	21.5	29.5	14
EDRV-06-8/6	PA 10020	8/6	34	8.0	G1/8	16.5	1.0	16	22.5	30.5	14
EDRV-08-6/4	PA 12001	6/4	38	10.5	G1/4	19.5	1.2	20	23.0	33.0	17
EDRV-08-8/6	PA 12002	8/6	38	10.5	G1/4	19.5	1.2	20	24.0	34.0	17
EDRV-08-10/8	PA 12003	10/8	38	10.5	G1/4	19.5	1.2	20	26.0	36.0	17

Dimensions in mm



Screw-in throttle check valves M5 – G1/4

Screw-in version

Series EDRV
Series SEDRV

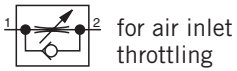
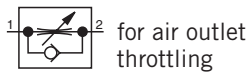

Versions
– with tube connection
– for air inlet and air outlet throttling

This valve is used for regulating the piston speed of pneumatic cylinders.

Characteristics			Pressures quoted as gauge pressure		
Characteristics	Symbol	Unit	Description		
General features					
Mounting			Screw-in valve		
Tube connection			Thread		
Port size			M5	G1/8	G1/4
Installation			In any position		
Mediums- und Ambient temperature range		T_{min} T_{max}	°C °C	0 +80	Note: When using below freezing point (0 °C) it is necessary to consult us
Material					
– Housing			Brass nickel-plated		
– O-ring			Buna N		
– Seals			Synthetic material		
Medium			Filtered compressed air		
Lubrication			Oil mist lubrication compatible with Buna N		
Pneumatische characteristics					
Nominal pressure		p_n	bar	6	
Operating pressure range		p_{max}	bar	10	
Nominal flow			M5	G1/8	G1/4
Type SEDRV-...A		Q_N	l/min	Ø4/2 – 45	
Type SEDRV		Q_N	l/min	Ø4/2 – 310 Ø5/3 – 310 Ø6/4 – 390 Ø8/6 – 390	Ø6/4 – 710 Ø8/6 – 810 Ø10/8 – 810
Type EDRV		Q_N	l/min	Ø5/3 – 310 Ø6/4 – 310 Ø8/6 – 310	Ø6/4 – 420 Ø8/6 – 420
Type EDRV		Q_N	l/min	310	450



Dimensions in mm

Screw-in throttle check valves
Type: EDRV-....BI

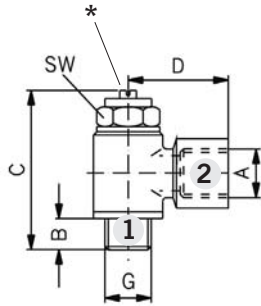

* Throttle screw

Screw-in throttle check valves
Type: EDRV-....B

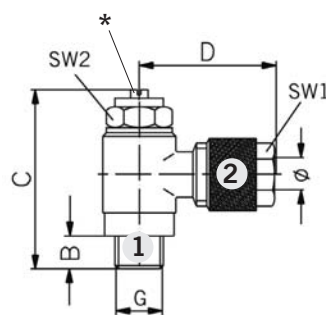

* Throttle screw

Screw-in throttle check valves
Type: SEDRV-....B

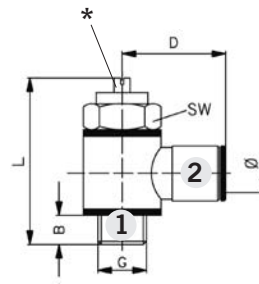

* Throttle screw

Screw-in throttle check valves M5 – G1/4

Screw-in version

Series EDRV
Series SEDRV



Screw-in throttle check valves with push-in fittings – Type SEDRV-....B Dimension table and order instructions

Order Instructions		∅	G	B	D	L	SW
Type	Order No.						
SEDRV-184B	KW 0530	4/2	G1/8	5.5	21.0	31.5	14
SEDRV-185B	KW 0531	5/3	G1/8	5.5	22.5	31.5	14
SEDRV-186B	KW 0532	6/4	G1/8	5.5	22.5	31.5	14
SEDRV-146B	KW 0533	6/4	G1/4	6.0	24.0	38.0	17
SEDRV-188B	KW 0534	8/6	G1/8	5.5	24.5	31.5	14
SEDRV-148B	KW 0535	8/6	G1/4	6.0	26.0	38.0	17
SEDRV-1410B	KW 0536	10/8	G1/4	6.0	28.0	38.0	17

Screw-in throttle check valves with union nut – Type EDRV-....B Dimension table and order instructions

Order Instructions		∅	G	B	C	D	SW1	SW2
Type	Order No.							
EDRV-185B	KW 0540	5/3	G1/8	5.5	36	23.0	8	14
EDRV-186B	KW 0541	6/4	G1/8	5.5	36	23.0	10	14
EDRV-146B	KW 0542	6/4	G1/4	6.0	38	26.0	10	17
EDRV-188B	KW 0543	8/6	G1/8	5.5	36	23.0	12	14
EDRV-148B	KW 0544	8/6	G1/4	6.0	38	26.0	12	17

Screw-in throttle check valves with internal thread – Type EDRV-....BI Dimension table and order instructions

Order Instructions		G	B	C	D	SW
Type	Order No.					
EDRV-1818BI	KW 0537	G1/8	4.5	36.0	16.0	14
EDRV-1414BI	KW 0538	G1/4	6.5	38.0	25.5	17

Dimensions in mm



Screw-in throttle check valves M5 – G1/4

Screw-in version

Series EDRV
Series SEDRV

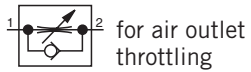

Screw-in throttle check valves
Type: EDRV-....AI

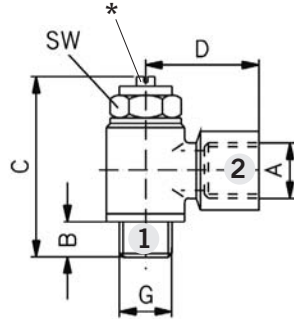

* Throttle screw

Screw-in throttle check valves
Type: EDRV-....A

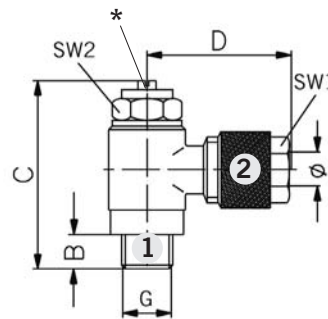

* Throttle screw

Screw-in throttle check valves
Type: SEDRV-....A

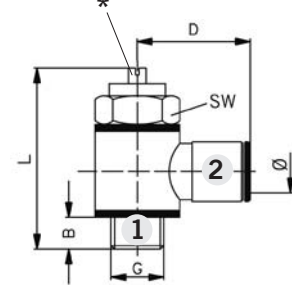

* Throttle screw

Screw-in throttle check valves with push-in fittings – Type SEDRV-....A Dimension table and order instructions

Order Instructions		∅	G	B	D	L	SW
Type	Order No.						
SEDRV-54A	KW0511	4/2	M5	6.0	17.0	24.5	8
SEDRV-184A	KW0512	4/2	G1/8	5.5	21.0	31.5	14
SEDRV-55A	KW0513	5/3	G1/8	5.5	22.5	31.5	14
SEDRV-186A	KW0515	6/4	G1/8	5.5	22.5	31.5	14
SEDRV-146A	KW0516	6/4	G1/4	6.0	24.0	38.0	17
SEDRV-188A	KW0517	8/6	G1/8	5.5	24.5	31.5	14
SEDRV-148A	KW0518	8/6	G1/4	6.0	26.0	38.0	17
SEDRV-1410A	KW0519	10/8	G1/4	6.0	28.0	38.0	17

Screw-in throttle check valves with union nut – Type EDRV-....A Dimension table and order instructions

Order Instructions		∅	G	B	C	D	SW1	SW2
Type	Order No.							
EDRV-185A	KW0524	5/3	G1/8	5.5	36	23.0	8	14
EDRV-186A	KW0525	6/4	G1/8	5.5	36	23.0	10	14
EDRV-146A	KW0526	6/4	G1/4	6.0	38	26.0	10	17
EDRV-188A	KW0527	8/6	G1/8	5.5	36	23.0	12	14
EDRV-148A	KW0528	8/6	G1/4	6.0	38	26.0	12	17

Screw-in throttle check valves with internal thread – Type EDRV-....AI Dimension table and order instructions

Order Instructions		G	B	C	D	SW
Type	Order No.					
EDRV-1818AI	KW0520	G1/8	4.5	36.0	16.0	14
EDRV-1414AI	KW0521	G1/4	6.5	38.0	25.5	17



Dimensions in mm

Characteristics

Pressures quoted as gauge pressure

Characteristics	Symbol	Unit	Description
General features			
Mounting			Screw-in valve
Tube connection			Thread
Port size			G1/8 G1/4
Installation			In any position
Mediums- und Ambient temperature range	T_{min} T_{max}	°C °C	0 Note: +80 When using below freezing point (0 °C) it is necessary to consult us
Material			
– Housing			Brass nickel-plated
– O-ring			Buna N
– Seals			Synthetic material
Medium			Filtered compressed air
Lubrication			Oil mist lubrication compatible with Buna N
Pneumatic characteristics			
Nominal pressure	p_n	bar	6
Operating pressure range	p_{max}	bar	10
Nominal flow			G1/8 G1/4
Type SEDRV-....Msv	Q_N	l/min	Ø4/2–310 Ø6/4–390 Ø8/6–390
			Ø6/4–710 Ø8/6–810 Ø10/8–810 Ø12/10–810

Screw-in throttle check valves G1/8, G1/4

Screw-in version

Series SEDRV

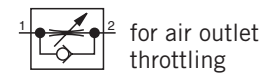

Versions

–with tube connection
–for air inlet and air outlet throttling

This valve is used for regulating the piston speed of pneumatic cylinders.



Dimensions in mm

Screw-in throttle check valves G1/8, G1/4

Screw-in version

Series SEDRV

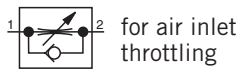

Screw-in throttle check valves Type: SEDRV-....B

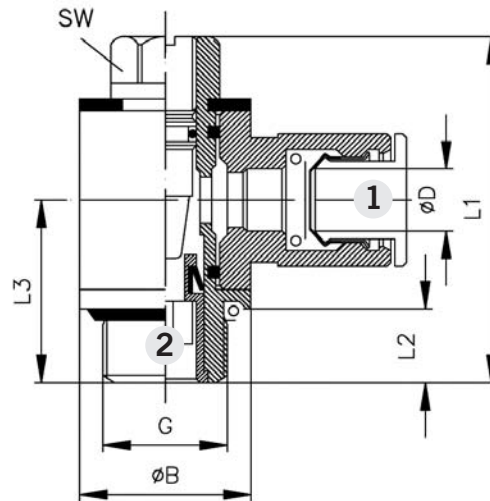

Screw-in throttle check valves with push-in fittings – Type SEDRV-....B
Dimension table and order instructions

Order Instructions	Order No.	ØD	G	ØB	L1	L2	L3	SW
SEDRV-184B-Msv	KW 1004	4/2	G1/8	14	32	6	15.0	9
SEDRV-186B-Msv	KW 1006	6/4	G1/8	14	32	6	15.0	9
SEDRV-146B-Msv	KW 1008	6/4	G1/4	18	37	8	18.5	12
SEDRV-188B-Msv	KW 1007	8/6	G1/8	14	32	6	15.0	9
SEDRV-148B-Msv	KW 1009	8/6	G1/4	18	37	8	18.5	12
SEDRV-1410B-Msv	KW 1010	10/8	G1/4	18	37	8	18.5	12
SEDRV-1412B-Msv	KW 1011	12/10	G1/4	18	37	8	18.5	12



Dimensions in mm

Screw-in throttle check valves Type: SEDRV-....A

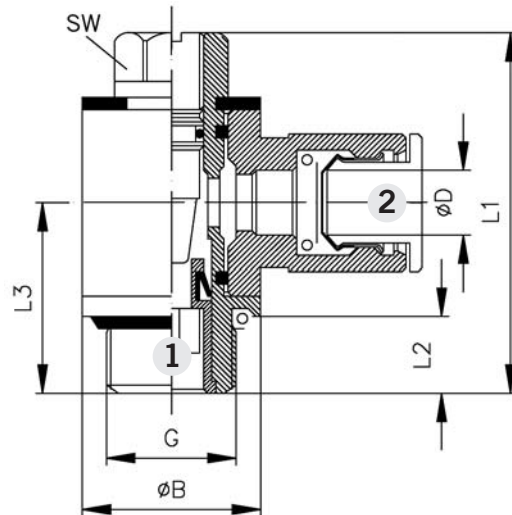

**Screw-in
throttle check
valves
G1/8, G1/4**

Screw-in version

Series SEDRV

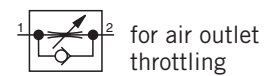

**Screw-in throttle check valves with push-in fittings – Type SEDRV-....A
Dimension table and order instructions**

Order Instructions	Order No.	ØD	G	ØB	L1	L2	L3	SW
SEDRV-184A-Msv	KW 1018	4/2	G1/8	14	32	6	15.0	9
SEDRV-186A-Msv	KW 1020	6/4	G1/8	14	32	6	15.0	9
SEDRV-146A-Msv	KW 1022	6/4	G1/4	18	37	8	18.5	12
SEDRV-188A-Msv	KW 1021	8/6	G1/8	14	32	6	15.0	9
SEDRV-148A-Msv	KW 1023	8/6	G1/4	18	37	8	18.5	12
SEDRV-1410A-Msv	KW 1024	10/8	G1/4	18	37	8	18.5	12
SEDRV-1412A-Msv	KW 1025	12/10	G1/4	18	37	8	18.5	12

Dimensions in mm



Screw-in throttle check valves M5 – G1/4

Screw-in version

Series EDRVK



Version:

- Short design, with slot and hexagon socket

Series EDRVK

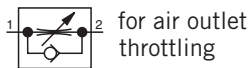

Version:

- Short design, with slot and hexagon socket

Screw-in throttle check valve Type: EDRVK-...B, EDRVK-...A

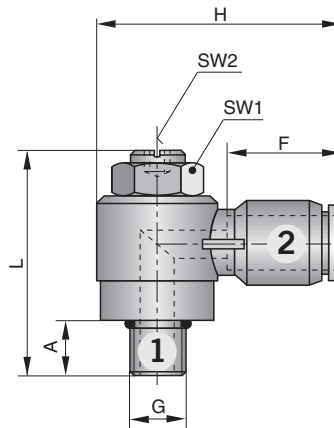

Dimension table and order instructions – Type: EDRVK-...B – for air inlet throttling

Order Instructions		G	Tube ØOD	A	L _{max} *	H	F	SW1	SW2	Q _N [Nl/min]
Type	Order No.									
EDRVK-54B-MsvKU	KT0452	M5	4	3.6	23.1	25.1	16.3	8	–	130
EDRVK-56B-MsvKU	KT0453	M5	6	3.6	23.1	27.8	17.6	8	2	130
EDRVK-184B-MsvKU	KT0454	G1/8	4	6.0	30.4	30.5	16.3	8	2	300
EDRVK-186B-MsvKU	KT0455	G1/8	6	6.0	30.4	31.2	17.6	8	2	400
EDRVK-188B-MsvKU	KT0456	G1/8	8	6.0	30.4	33.0	18.7	8	2	400
EDRVK-146B-MsvKU	KT0457	G1/4	6	8.0	36.3	35.0	17.6	12	2	620
EDRVK-148B-MsvKU	KT0458	G1/4	8	8.0	36.3	36.8	18.7	12	2	720
EDRVK-1410B-MsvKU	KT0459	G1/4	10	8.0	36.3	38.8	19.6	12	2	720

Material: plastic/nickel-plated brass

*If the throttle is completely open

Dimension table and order instructions – Type: EDRVK-...A – for air outlet throttling

Order Instructions		G	Tube ØOD	A	L _{max} *	H	F	SW1	SW2	Q _N [Nl/min]
Type	Order No.									
EDRVK-54A-MsvKU	KT0460	M5	4	3.6	23.1	25.1	16.3	8	–	130
EDRVK-56A-MsvKU	KT0461	M5	6	3.6	23.1	27.8	17.6	8	2	130
EDRVK-184A-MsvKU	KT0462	G1/8	4	6.0	30.4	30.5	16.3	8	2	300
EDRVK-186A-MsvKU	KT0463	G1/8	6	6.0	30.4	31.2	17.6	8	2	400
EDRVK-188A-MsvKU	KT0464	G1/8	8	6.0	30.4	33.0	18.7	8	2	400
EDRVK-146A-MsvKU	KT0465	G1/4	6	8.0	36.3	35.0	17.6	12	2	620
EDRVK-148A-MsvKU	KT0466	G1/4	8	8.0	36.3	36.8	18.7	12	2	720
EDRVK-1410A-MsvKU	KT0467	G1/4	10	8.0	36.3	38.8	19.6	12	2	720

Material: plastic/nickel-plated brass

*If the throttle is completely open



Dimensions in mm

Screw-in throttle check valve Type: EDRV...B, EDRV...A

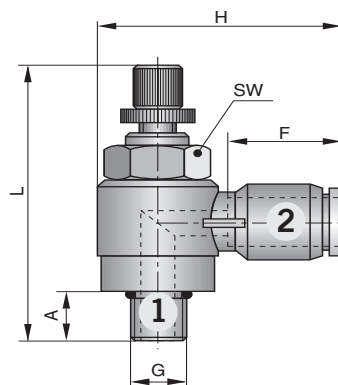

Dimension table and order instructions – Type: EDRV...B – for air inlet throttling

Order Instructions	Order No.	Tube ØOD	G	A	L _{max} *	H	F	SW	Q _N [Nl/min]
EDRV-54B-MsvKU	KT0417	4	M5	4.6	37.0	26.6	16.8	8	100
EDRV-56B-MsvKU	KT0418	6	M5	4.6	37.0	27.2	17.6	8	100
EDRV-184B-MsvKU	KT0419	4	G1/8	4.5	40.1	30.9	16.3	8	165
EDRV-186B-MsvKU	KT0420	6	G1/8	4.5	40.1	31.4	17.6	8	165
EDRV-188B-MsvKU	KT0421	8	G1/8	4.5	40.1	34.2	18.7	8	165
EDRV-146B-MsvKU	KT0422	6	G1/4	5.5	47.6	35.6	17.6	12	410
EDRV-148B-MsvKU	KT0423	8	G1/4	5.5	47.6	38.3	18.7	12	410
EDRV-1410B-MsvKU	KT0424	10	G1/4	5.5	47.6	39.5	19.6	12	410
EDRV-1412B-MsvKU	KT0425	12	G1/4	5.5	47.6	41.8	21.9	12	410
EDRV-386B-MsvKU	KT0426	6	G3/8	6.0	55.9	39.0	17.6	12	500
EDRV-388B-MsvKU	KT0427	8	G3/8	6.0	55.9	40.0	18.7	12	500
EDRV-3810B-MsvKU	KT0428	10	G3/8	6.0	55.9	42.5	19.6	12	500
EDRV-3812B-MsvKU	KT0429	12	G3/8	6.0	55.9	45.5	21.9	12	500
EDRV-1210B-MsvKU	KT0430	10	G1/2	7.0	59.6	47.1	19.6	19	900
EDRV-1212B-MsvKU	KT0431	12	G1/2	7.0	59.6	50.3	21.9	19	900

Material: plastic/nickel-plated brass
*If the throttle is completely open

Dimension table and order instructions – Type: EDRV...A – for air outlet throttling

Order Instructions	Order No.	Tube ØOD	G	A	L _{max} *	H	F	SW	Q _N [Nl/min]
EDRV-54A-MsvKU	KT0432	4	M5	4.6	37.0	26.6	16.8	8	100
EDRV-56A-MsvKU	KT0433	6	M5	4.6	37.0	27.2	17.6	8	100
EDRV-184A-MsvKU	KT0434	4	G1/8	4.5	40.1	30.9	16.3	8	165
EDRV-186A-MsvKU	KT0435	6	G1/8	4.5	40.1	31.4	17.6	8	165
EDRV-188A-MsvKU	KT0436	8	G1/8	4.5	40.1	34.2	18.7	8	165
EDRV-146A-MsvKU	KT0437	6	G1/4	5.5	47.6	35.6	17.6	12	410
EDRV-148A-MsvKU	KT0438	8	G1/4	5.5	47.6	38.3	18.7	12	410
EDRV-1410A-MsvKU	KT0439	10	G1/4	5.5	47.6	39.5	19.6	12	410
EDRV-1412A-MsvKU	KT0440	12	G1/4	5.5	47.6	41.8	21.9	12	410
EDRV-386A-MsvKU	KT0441	6	G3/8	6.0	55.9	39.0	17.6	12	500
EDRV-388B-MsvKU	KT0442	8	G3/8	6.0	55.9	40.0	18.7	12	500
EDRV-3810B-MsvKU	KT0443	10	G3/8	6.0	55.9	42.5	19.6	12	500
EDRV-3812B-MsvKU	KT0444	12	G3/8	6.0	55.9	45.5	21.9	12	500
EDRV-1210B-MsvKU	KT0445	10	G1/2	7.0	59.6	47.1	19.6	19	900
EDRV-1212B-MsvKU	KT0446	12	G1/2	7.0	59.6	50.3	21.9	19	900

Material: plastic/nickel-plated brass
*If the throttle is completely open

Screw-in throttle check valves M5 – G1/2

Screw-in version

Series EDRV



Series EDRV

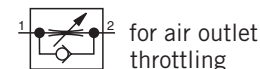

Delivery includes:
rotating ring, two seals and O-ring, preassembly



ARA[®]
PNEUMATIK

53-012 Wrocław tel. 71 364 72 82
ul. Wyścigowa 38 fax 71 364 72 83

www.arapneumatik.pl



Dimensions in mm